



(22) **Date de dépôt/Filing Date:** 2011/01/13
(41) **Mise à la disp. pub./Open to Public Insp.:** 2011/07/21
(45) **Date de délivrance/Issue Date:** 2020/07/28
(62) **Demande originale/Original Application:** 2 787 152
(30) **Priorité/Priority:** 2010/01/13 (US61/335,947)

(51) **Cl.Int./Int.Cl. A61F 2/30** (2006.01),
A61B 17/17 (2006.01), **A61B 17/70** (2006.01),
A61F 2/46 (2006.01)
(72) **Inventeur/Inventor:**
DONNER, EDWARD JEFFREY, US
(73) **Propriétaire/Owner:**
JCBD, LLC, US
(74) **Agent:** SMART & BIGGAR LLP

(54) **Titre : SYSTEME DE FUSION DE FIXATION D'ARTICULATION SACRO-ILIAQUE**

(54) **Title: SACROILIAC JOINT FIXATION FUSION SYSTEM**

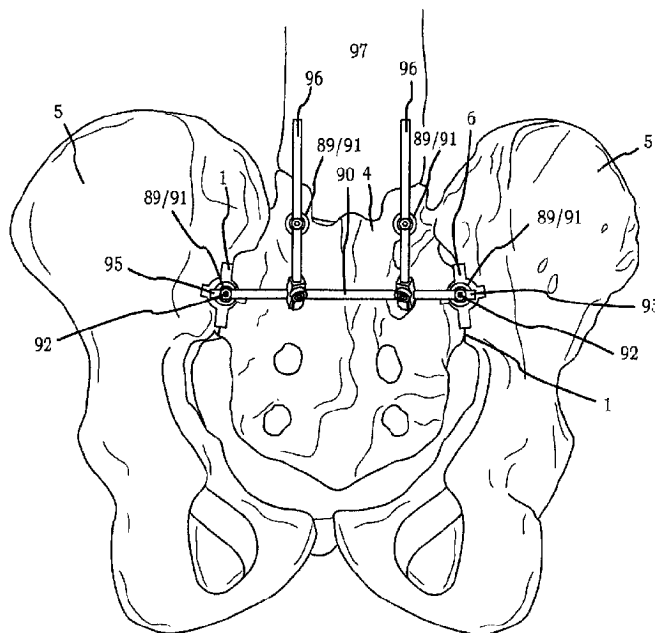

(57) **Abrégé/Abstract:**

A system for fixing a sacroiliac joint that includes a sacroiliac joint implant for implantation in the sacroiliac joint. The sacroiliac joint implant includes an elongate body including a first end a second end and a length disposed between the first end and the second end. The elongate body is adapted to non-transversely locate within the sacroiliac joint. The system also includes a coupling element configured to connect to the sacroiliac joint implant. The system further includes a spanning member securable to the coupling element and a second coupling element engageable with the spanning member.

ABSTRACT

A system for fixating a sacroiliac joint that includes a sacroiliac joint implant for implantation in the sacroiliac joint. The sacroiliac joint implant includes an elongate body including a first end a second end and a length disposed between the first end and the second end. The elongate body is adapted to non-transversely locate within the sacroiliac joint. The system also includes a coupling element configured to connect to the sacroiliac joint implant. The system further includes a spanning member securable to the coupling element and a second coupling element engageable with the spanning member.

SACROILIAC JOINT FIXATION FUSION SYSTEM

This application is divided from Canadian Patent Application Serial No. 2,787,152 filed on January 13, 2011.

5

I. TECHNICAL FIELD

Generally, a sacroiliac joint fixation fusion system that provides a method of fixation and fusion of the sacroiliac joint and a sacroiliac joint implant which upon placement within the articular space of the sacroiliac joint facilitates stability and fusion of the sacroiliac joint.

10 II. BACKGROUND

The sacroiliac joint is the joint between the sacrum and the ilium of the pelvis, which are joined by ligaments. In humans, the sacrum supports the spine and is supported in turn by an ilium on each side. The sacroiliac joint is a synovial joint with articular cartilage and irregular elevations and depressions that produce interlocking of the two bones.

15 Pain associated with the sacroiliac joint can be caused by traumatic fracture dislocation of the pelvis, degenerative arthritis, sacroiliitis an inflammation or degenerative condition of the sacroiliac joint, osteitis condensans ilii, or other degenerative conditions of the sacroiliac joint. Currently, sacroiliac joint fusion is most commonly advocated as a surgical treatment for these conditions. Fusion of the sacroiliac joint can be accomplished by
20 several different conventional methods encompassing an anterior approach, a posterior approach, and a lateral approach with or without percutaneous screw or other type implant fixation. However, while each of these methods have been utilized for fixation and fusion of the sacroiliac joint over the past several decades, substantial problems with respect to the fixation and fusion of the sacroiliac joint remain unresolved.

25 A significant problem with certain conventional methods for fixation and fusion of the sacroiliac joint including the anterior approach, posterior approach, or lateral approach may be that the surgeon has to make a substantial incision in the skin and tissues for direct access to the sacroiliac joint involved. These invasive approaches allow the sacroiliac joint to be seen and touched directly by the surgeon. Often referred to as an "open surgery", these

procedures have the attendant disadvantages of requiring general anesthesia and can involve increased operative time, hospitalization, pain, and recovery time due to the extensive soft tissue damage resulting from the open surgery. A danger to open surgery using the anterior approach can be damage to the L5 nerve root which lies approximately two centimeters medial to the sacroiliac joint or damage to the major blood vessels. Additionally, these procedures typically involve fixation of the sacroiliac joint (immobilization of the articular surfaces of the sacroiliac joint in relation to one another) by placement of one or more screws or by placement of one or more trans-sacroiliac implants (as shown by the non-limiting example of Figure 1) or by placement of implants into the S1 pedicle and iliac bone. Use of trans-sacroiliac and S1 pedicle-iliac bone implants can also involve the risk of damage to the lumbosacral neurovascular elements. Damage to the lumbosacral neurovascular elements as well as delayed union or non-union of the sacroiliac joint by use of these procedures may require revision surgery to remove all or a portion of the implants or repeat surgery as to these complications.

15

Another significant problem with conventional procedures utilizing minimally invasive small opening procedures can be that the procedures are technically difficult requiring biplanar fluoroscopy of the articular surfaces of the sacroiliac joint and extensive surgical training and experience. Despite the level of surgical training and experience, there is a substantial incidence of damage to the lumbosacral neurovascular elements. Additionally, sacral anomalies can further lead to mal-placement of implants leading to damage of surrounding structures. Additionally, these procedures are often performed without fusion of the sacroiliac joint which does not remove the degenerative joint surface and thereby does not address the degenerative condition of the sacroiliac joint which may lead to continued or recurrent sacroiliac joint pain.

Another significant problem with conventional procedures can be the utilization of multiple trans-sacroiliac elongate implants, which do not include a threaded surface. This approach requires the creation of trans-sacroiliac bores in the pelvis and nearby sacral foramen which can be of relatively large dimension and which are subsequently broached with instruments which can result in bone being impacted into the pelvis and neuroforamen.

The creation of the trans-sacroiliac bores and subsequent broaching of the bores requires a guide pin which may be inadvertently advanced into the pelvis or sacral foramen

5 resulting in damage to other structures. Additionally, producing the trans-sacroiliac bores, broaching, or placement of the elongate implants may result in damage to the lumbosacral neurovascular elements, as above discussed. Additionally, there may be no actual fusion of the articular portion of the sacroiliac joint which may result in continued or recurrent pain requiring additional surgery.

10 Another substantial problem with conventional procedures can be that placement of posterior extra-articular distracting fusion implants and bone grafts as described for example in United States Patent Application Publication No. US 2008/0009861 of Stark may be inadequate with respect to removal of the articular surface or preparation of cortical bone, the implant structure and fixation of the sacroiliac joint. The method may not remove sufficient amounts of the articular surfaces or cortical surfaces of the sacroiliac joint to relieve pain in the sacroiliac joint. The implant structures described may have insufficient or avoid engagement with the articular surfaces or cortical bone of the sacroiliac joint for adequate fixation or fusion. The failure to sufficiently stabilize and fuse the sacroiliac joint with the implant structures and methods described by the Stark application may result in a failure to relieve the condition of sacroiliac joint being treated. Additionally, the method of driving apart a sacrum and ilium as described by Stark may lead to mal-alignment of the sacroiliac joint and increased pain.

20

Illustrative embodiments of the inventive sacroiliac fusion system described herein may address one or more of the problems associated with conventional methods and apparatuses used in fixation and fusion of the sacroiliac joint.

25 III. DISCLOSURE OF ILLUSTRATIVE EMBODIMENTS

Accordingly, an illustrative embodiment may provide an inventive sacroiliac joint implant for fixation and fusion of the sacroiliac joint. Embodiments of the sacroiliac joint implant can provide an elongate body, which can further include at least one radial member, or a pair of members which extend distance radially outward from the longitudinal axis of the elongate body adapted for non-transverse placement between the articular surfaces of the

30

sacroiliac joint and as to certain embodiments can further provide a third radial member and additionally a fourth radial member each adapted to extend a distance radially outward from the longitudinal axis of the elongate body into the bone of the sacrum or the ilium.

5 Another illustrative embodiment may provide an inventive method for fixation and fusion of the sacroiliac joint which utilizes the inventive sacroiliac implant. The inventive method comprising the steps of performing a minimally invasive posterior surgery that allows access to the posterior aspect of the sacroiliac joint for removing a sufficient portion of the articular cartilage or tissue between the articular surfaces of the sacroiliac joint which can
10 be replaced by embodiments of the above described sacroiliac implant. A portion of the subcondral bone of the sacroiliac joint can be removed to provide an implant receiving space in the plane of the sacroiliac joint (non-trans-sacroiliac) configured to allow interference fitting of the elongate member, or the elongate member with at least a first radial member between the opposed surfaces of the implant receiving space. The inventive method can
15 further include the step of providing the implant receiving space with one or more radial member receiving channels cut into the bone (including one or more of the subchondral, cortical, or cancellous) and thereby locating one or more radial members in the bone of the sacrum or the bone of the ilium. The inventive method avoids conventional trans-sacroiliac placement of fixation elements or S 1 pedicle and intrailiac screws joined by a rod while
20 providing immediate fixation of the sacroiliac joint.

 Another illustrative embodiment may provide one or more bone ingrowth aperture elements which communicate between the opposed surfaces of one or more radial members or through the generally linear elongate body each having a configuration which allows the bone
25 of the sacrum and ilium to grow into or through the implant to facilitate fusion of the sacrum to the ilium and fixation of the sacroiliac joint.

 Another illustrative embodiment may provide the inventive fixation fusion implant with an amount of curvature along the length of the implant which allows placement of
30

embodiments of the fixation fusion implant which have an increased surface area which remain within or substantially within the articular portion of the sacroiliac joint.

5 One illustrative embodiment provides a system for fixating a sacroiliac joint, the system comprising: a sacroiliac joint implant for implantation in the sacroiliac joint, the sacroiliac joint implant comprising an elongate body including a first end, a second end, a length disposed between the first end and the second end, and a rectilinear cross-section transverse to the length, the elongate body being adapted to non-transversely locate within the sacroiliac joint; a first coupling element configured to connect to the sacroiliac joint implant;
10 a spanning member securable to the first coupling element; and a second coupling element engageable with the spanning member.

Other aspects and features of illustrative embodiments will become apparent to those ordinarily skilled in the art upon review of the following description of such embodiments in
15 conjunction with the accompanying figures.

IV. BRIEF DESCRIPTION OF THE DRAWINGS

Figure 1 is an anterior view of the pelvic region and a conventional method and device for stabilizing the sacroiliac joint.

5 Figure 2 is a perspective view of a particular embodiment of the sacroiliac joint implant.

Figure 3 is a first side view of a particular embodiment of the sacroiliac joint implant.

10 Figure 4 is a first implant end view of a particular embodiment of the sacroiliac joint implant.

Figure 5 is a second implant end view of a particular embodiment of the sacroiliac joint implant.

15

Figure 6 is second side view of the particular embodiment of the sacroiliac joint implant shown in Figure 3 rotated about 90 degrees about the longitudinal axis.

20 Figure 7 is a perspective view of a second particular embodiment of the sacroiliac joint implant.

Figure 8 is a first side view of another particular embodiment of the fixation fusion implant having a coat material which facilitates osseointegration of the fixation fusion implant with the bone.

25

Figure 9 is a cross section 8-8 as shown in Figure 8 of that particular embodiment of the fixation fusion implant.

30 Figure 10 is a perspective view of an embodiment of the sacroiliac joint implant having an amount of curvature along the longitudinal axis.

Figure 11 is a first side view of the particular embodiment of the fixation fusion implant shown in Figure 10.

Figure 12 is a first implant end view of a particular embodiment of the fixation fusion implant shown in Figure 11.

Figure 13 is a second implant end view of a particular embodiment of the fixation fusion implant shown in Figure 11.

Figure 14 is second side view of the particular embodiment of the fixation fusion implant shown in Figure 11 rotated about 90 degrees about the longitudinal axis.

Figure 15 is a side view of the embodiment of the sacroiliac joint implant shown in Figure 10 produced in a plurality of implantable parts.

Figure 16 is a cross section view through the sacroiliac joint which illustrates a method of implanting an embodiment of the sacroiliac joint implant the step including insertion of a needle into the articular plane of the sacroiliac joint to inject a radiographic dye to allow fluoroscopic visualization of the sacroiliac joint.

Figure 17 is a cross section view through the sacroiliac joint which illustrates a method of implanting an embodiment of the sacroiliac joint implant the step including fixing the tubular needle within the sacroiliac joint as a guide wire.

Figure 18 is a cross section view through the sacroiliac joint which illustrates a method of implanting an embodiment of the sacroiliac joint implant the step including advancing a body of a cannulated probe along the needle fixed in the sacroiliac joint to fixed location at the anterior portion of the sacroiliac joint.

Figure 19 is a cross section view through the sacroiliac joint which illustrates a method of implanting an embodiment of the sacroiliac joint implant the step including advancing an tissue dialator along the body of the cannulated probe fixed in the sacroiliac joint to allow placement of a cannula against the surface of the sacrum and ilium to expose the sacroiliac joint.

Figure 20A is a posterior view of the pelvic region showing fixed placement of the cannula in relation to the sacroiliac joint having inserted within a cannula alignment jig.

Figure 20B is a perspective view of the cannula jig insert shown in Figure 20A having cross hairs.

5 Figure 20C is a perspective view of the cannula shown in Figure 20B having a cannula alignment jig inserted within having alignable cross hairs.

Figure 21A is a posterior view of the pelvic region showing fixed placement of the cannula in relation to the sacroiliac joint having within a first drill jig.

10

Figure 21B is a perspective view of the cannula of Figure 21A having within the first drill jig.

15 Figure 22 is a cross section view through the sacroiliac joint which illustrates a method of implanting an embodiment of the fixation fusion implant the step including replacement of the tissue dialator with a first drill jig which receives a cannulated drill for production of a first bore hole substantially along the articular plane of the sacroiliac joint.

20 Figure 23 is a cross section view through the sacroiliac joint which illustrates a method of implanting an embodiment of the sacroiliac implant the step including replacement of the first drill jig with a second drill jig which allows additional bore holes to be produced in relation to the first bore hole each substantially along the articular plane of the sacroiliac joint.

25 Figure 24 is a cross section view through the sacroiliac joint which illustrates a method of implanting an embodiment of the fixation fusion implant the step including replacement of the second drill jig (or the first drill jig depending on the method) with a broach jig which receives a cannulated broach which can be advanced into the sacroiliac joint to produce an implant receiving space.

30

Figure 25 is a lateral view of the pelvic region which shows an embodiment of the sacroiliac joint implant located between the caudal articular surfaces (shown in broken line) of the sacroiliac joint.

Figure 26A provides a cutaway view of the sacroiliac joint showing placement of a particular embodiment of the fixation fusion implant in the implant receiving space produced by the method illustrated in Figures 16-24.

5 Figure 26B is an enlarged view of a portion of Figure 26A showing placement of a particular embodiment of the fixation fusion implant in the implant receiving space produced by the method illustrated in Figures 16-24.

10 Figure 26C is a cross section view 26C-26C shown in Figure 26B which shows the configuration of the implant receiving space produced by the method illustrated in Figures 16-25 and a particular embodiment of the fixation fusion implant implanted therein implanted.

15 Figure 27 provides a lateral view of the pelvis showing an embodiment of the sacroiliac implant located between the cranial articular surfaces (shown in broken line) within articular plane of the sacroiliac joint.

20 Figure 28A provides a cutaway view of the sacroiliac joint showing placement of a particular embodiment of the fixation fusion implant in the implant receiving space produced by the method illustrated in Figures 16-24.

25 Figure 28B is an enlarged view of a portion of Figure 26A showing placement of a particular embodiment of the fixation fusion implant in the implant receiving space produced by the method illustrated in Figures 16-24.

30 Figure 28C is a cross section view 28C-28C shown in Figure 28B which shows the configuration of the implant receiving space produced by the method illustrated in Figures 16-24 and a particular embodiment of the fixation fusion implant implanted therein implanted.

 Figure 29 provides a lateral view of the pelvis with an embodiment of the fixation fusion implant located substantially between the cranial and caudal articular surfaces (shown in broken line) and to a limited extent extra-articular of the sacroiliac joint.

Figure 30 provides a lateral view of the pelvis with an embodiment of the fixation fusion implant located between the cranial and caudal articular surfaces (shown in broken line) within the articular plane of the sacroiliac joint.

5 Figure 31 is a cross section view through the sacroiliac joint which illustrates an alignment tool attachable to an implanted sacroiliac joint implant which aligns an elongate member to pass through the sacroiliac joint implant.

10 Figure 32 is a cross section view through the sacroiliac joint which illustrates a coupling element joined to the first end of an implanted sacroiliac joint implant.

Figure 33 is a posterior view of the pelvic region which shows a spanning member joined to a corresponding pair of coupling elements correspondingly joined to the first end of a pair of implanted sacroiliac joint implants.

15

Figure 34 is a posterior view of the pelvic region which shows a spanning member joined to a corresponding pair of coupling elements correspondingly joined to an implanted sacroiliac joint implant and directly engaged to the sacrum.

20 V. MODE(S) FOR CARRYING OUT THE INVENTION

Generally, a sacroiliac joint fixation fusion system that provides a method of fixation and fusion of the sacroiliac joint and a sacroiliac joint implant which upon placement within the articular region of the sacroiliac joint facilitates stability and fusion of the sacroiliac joint.

25

Now referring primarily to Figure 1 which shows one commonly utilized conventional method and device for fixation of the sacroiliac joint (1). The conventional device shown comprises one or more substantially linear elongate members (2) which can be inserted into correspondingly dimensioned trans-iliac bores (3) with a first portion extending into the bone of sacrum (4) and a second portion extending into the bone of the ilium (5), thereby extending across the sacroiliac joint (1). The one or more substantially linear elongate members (2) (which can be configured as cylindrical rods which can further include an amount of taper or further include a spiral thread coupled to the exterior surface to avoid the need for generating trans-iliac bores) in trans-iliac placement can locate the ilium (5) in

fixed relation to the sacrum (4). However, this trans-iliac placement of such substantially linear elongate members (2) can have the disadvantages described above. Additionally, conventional placement of the trans-iliac bores (3) and the elongate members (2) can be outside of that region defined by the boundary of the paired articular surfaces (16)(also commonly referred to as the “auricular surfaces”) of the sacroiliac joint (1), as further described below.

Now referring primarily to Figures 2-6, an embodiment of an inventive sacroiliac joint implant (6) is shown which in part can include an elongate body (7) which having a longitudinal axis (8). The elongate body (7) can have a configuration of sufficient dimension to avoid deformation under the normal forces of surgical placement and fixation of the ilium (5) in relation to the sacrum (4). Accordingly, while the embodiment of the sacroiliac joint implant (6) shown in Figures 2-6 can be generally cylindrical or circular in cross section; the invention is not so limited, and the elongate body (7) can have any of a numerous and varied configurations in cross section consistent with the method herein after described such as oval, triangular, rectangular, square, diamond, or the like. As one non-limiting example, the generally cylindrical elongate body (7) shown in Figure 2 can depending on the application have a diameter of in the range of about 0.5 centimeters (“cm”) to about 1 cm and a length disposed between a first implant end (11) and a second end (12) in the range of about 3 cm and about 6 cm.

As to particular embodiments of the invention, the elongate body (7) can further include an axial bore (9) that bounds an axial pathway (10) which communicates between a first implant end (11) and a second implant end (12) of the elongate body (7). The axial bore (9) allows for placement within the axial pathway (10) a guide pin (13) (or other guide member) about which embodiments of the sacroiliac joint implant (6) can be guided for insertion and placement in the sacroiliac joint (1), as further described below.

Again referring primarily to Figures 2-6, embodiments of the sacroiliac joint implant (6) can further include a first radial member (14) coupled to the external surface of the elongate body (7) extending radially outward generally along the longitudinal axis (8). As to certain embodiments of the sacroiliac joint implant (6) as shown in the Figures, the first radial member (14) can extend along the longitudinal axis (8) substantially the entire length of the elongate body (7); however, the invention is not so limited, and embodiments of the inventive sacroiliac joint implant (6) can have a first radial member (14) which can in part or in a

plurality of discontinuous parts extend along the longitudinal axis (8) or the elongate body (7).

Again referring to Figures 2-6, embodiments of the sacroiliac joint implant (6) can further include a second radial member (15). Each of the first radial member (14) and the second radial member (15) can extend radially outward from the elongate body (7) generally in opposed relation (about 180 degrees apart about the longitudinal axis (8) of the elongate body (7); however, the invention is not so limited, and the first radial member (14) and the second radial member (15) can be spaced about the elongate body (7) a greater or lesser number of degrees. The configuration of each of the first radial member (14) or second radial member (15)(or both) can be adapted to non-transversely locate between the articular surfaces (16) of the sacroiliac joint (1) to dispose the sacrum (4) and the ilium (5) in substantially immobilized, immobilized, or fixed relation. The term "non-transversely" as used herein means not lying or extended across the joint between the sacrum (4) and the ilium (5) and in particular does not include trans-iliac placement of a sacroiliac joint implant as above described and shown in Figure 1. The term "articular surfaces" includes the two paired L-shaped surfaces formed between the surfaces of the sacrum (4) and the ilium (5) having a cranial portion (87) and a caudal portion (86) as shown for example in Figures 25, 27, and 29 (broken line) and as used herein does not include structures or regions of the sacrum (4) or the ilium (5) outside of the articular surfaces (16), such as, the paired iliac tuberosity and sacral fossa.

Each of the first radial member (14) and the second radial member (15) can each provide a pair of opposed faces (17)(18) disposed a thickness (19A) apart and having an area bound by a top edge (20), a pair of side edges (21)(22) and a bottom edge (23). The first of the pair of side edges (21) can be connected as above described to the elongate body (7) locating the second side edge (22) a distance outward from the longitudinal axis (8) of the elongate body (7). As a non-limiting example, each of the first radial member (14) and the second radial member (15) can be substantially rectangular in configuration having a height (28a) between the first of the pair of side edges (21) and the second of the pair of side edges (22) in the range of about 0.2 cm and about 1 cm. Understandably, a lesser diameter elongate body (7) may include a first radial member (14) and a second radial member (15)(or other radial members) having greater height (28a) and a greater diameter elongate body (7) may

require a first radial member (14) and a second radial member (15)(or other radial members) having lesser height (28a).

5 The top edge (20) of each of the first radial member (14) and the second radial member (15) can terminate substantially in alignment with the first implant end (11) of the elongate body (7). The bottom edge (23) of the first radial member (14) and the second radial member (15) can terminate substantially in alignment with second implant end (12) of the elongate body (7). As to certain embodiments, the bottom edge (23) can further include an angle element (24) which angles outward from the elongate body (7) commencing at the
10 second implant end (12) and joining the second of pair of side edges (22) a distance toward the first implant end (11). The angle element (24) can have a degree angle (25) from the perpendicular with the longitudinal axis (8) in a range of about fifteen degrees to about thirty degrees, as shown in Figure 2; however, the invention is not so limited and the angle element (24) can be a radius element, tapered element or other element to ease insertion into the
15 sacroiliac joint (1).

Again referring primarily to Figure 2-6, certain embodiments of the sacroiliac joint implant (6) can further include a third radial member (26) extending along the longitudinal axis (8) of said elongate body (7) adapted to extend into the cortical bone of the ilium (5).
20 Certain embodiments can further include a fourth radial member (27) extending along the longitudinal axis (8) of said elongate body (7) adapted to extend into the cortical bone of said sacrum (4). Certain embodiments of the third radial member (26) and the fourth radial member (27) can be adapted to extend into the bone of the sacrum (4) and the ilium (5) respectively.

25 As to the non-limiting embodiment of the sacroiliac joint implant (6) shown in Figure 3, the third radial member (26) and the fourth radial member (27) can be connected generally in line with the longitudinal axis (8) of the elongate body (7). Each of the third radial member (26) and the fourth radial member (27) can extend radially outward from the elongate body (7) substantially in opposed relation (about 180 degrees apart) and in
30 perpendicular relation (about 90 degrees) to the first radial member (14) and the second radial member (15)(see also Figures 8 and 9C); however, the invention is not so limited, and the third radial member (26) and the fourth radial member (27)(if the embodiment includes a fourth radial member (27)) can be spaced about the elongate body (7) in relation to each other

and in relation to the first radial member (14) and the second radial member (15) a greater or lesser number of degrees depending on the application and the amount of desired engagement with the bone of the sacrum (4) or ilium (5).

5 The configuration of each of the third radial member (26) or the fourth radial member (27) can vary as necessary to provide an amount of surface area engagable with the bone of the sacrum (4) and ilium (5) sufficient for facilitating substantial immobilization, immobilization, or to fix, the sacrum (4) in relation to the ilium (5) upon implantation of the sacroiliac joint implant (6) and to further provide a resistance to rotation or other undesired
10 movement of the sacroiliac joint implant (6) at the implant location within the region bounded by the articulating surfaces (16) of the sacroiliac joint (1). Accordingly, embodiments of the sacroiliac joint implant (6) having a third radial member (26) and the fourth radial member (27) can provide a pair of opposed faces (17)(18) disposed a thickness (19b) apart and have an area bound by a top edge (20), a pair of side edges (21) (22) and a
15 bottom edge (23) in similar configuration as above described for the first radial member (14) and the second radial member (15). The first of the pair of side edges (21) can be connected as above described to the elongate body (7) locating the second side edge (22) a distance outward from the longitudinal axis (8) of the elongate body (7). As a non-limiting example, each of the third radial member (26) and the fourth radial member (27) can have a
20 substantially rectangular configuration having a height (28b) between the first of the pair of side edges (21) and the second of the pair of side edges (22) in the range of about 0.1 cm and about 0.4 cm. The top edge (20) of each of the third radial member (26) and the fourth radial member (27) can terminate substantially in alignment with the first implant end (11) of the elongate body (7). The bottom edge (23) of the third radial member (26) and the fourth radial
25 member (27) can terminate substantially in alignment with second implant end (12) of the elongate body (7). As to certain embodiments, the bottom edge (23) of the third radial member (26) and the fourth radial member (27) can further include the angle element (24) which angles the second of the pair of side edges (22) toward the first implant end (11) of the elongate body (7). The angle element (24) can have a degree angle (25) from the
30 perpendicular with the longitudinal axis (8) in a range of about fifteen degrees to about thirty degrees; however, the invention is not so limited and with respect to certain embodiments of the invention there may be no angle element (24) or the angle element may be greater or less than within the range of about fifteen degrees to about thirty degrees. Additionally, the angle

element (24) can be similar as shown in the figures or can be dissimilar between the radial members of a particular sacroiliac joint implant (6) depending on the application.

Again referring primarily to Figures 2-6, and without limitation to forgoing, the third
5 radial member (26) and the fourth radial member (27) can have a lesser height (28b) than the
first radial member (14) and second radial member (15). While the structure of the third
radial member (26) and the fourth radial member (27) appear similar to the first radial
member (14) and the second radial member (15), the function can be substantially different.
The first radial member (14) and the second radial member (15) have a configuration (height,
10 length, thickness, surface area, and location in relation to the external surface of the elongate
body (7), as above described) capable of or allowing placement non-transversely between the
articular surfaces (16) (and not across) or within an implant receiving space (29) surgically
produced within the region bounded by the articular surfaces (16) by removal of a portion the
sacroiliac joint (1), as further described below, capable upon placement between the articular
15 surfaces (16) or within the implant receiving space (29) of substantially immobilizing or
immobilizing the sacroiliac joint (1).

By contrast, the third radial member (26), and as to those embodiments having a
fourth radial member (27), can have a configuration (height, length, thickness, surface area,
20 and location on the external surface of the elongate body (7), as above described) capable of
being forcibly urged a depth into the cortical bone or the cancellous bone of the sacrum (4)
or the ilium (5) or placed within the radial member receiving channel (74) of the implant
receiving space (29) upon non-transversely locating the sacroiliac joint implant (6) between
the articular surfaces (16) of the sacroiliac joint (1). The height of the third radial member
25 (26) and the fourth radial member (27) can be sufficient to resist rotation of the implanted
sacroiliac joint implant (6) to allow boney fusion of the cancellous bone to the sacroiliac
implant (6) or through apertures of the third radial member (26) or the fourth radial member
(27) or both similar to the first radial member (14) and second radial member (15). Now
referring primarily to Figure 2, each radial member (14)(15)(26)(27) extending outwardly
30 from the elongate body (7) can terminate in a radial member cross piece (98) disposed in
substantially perpendicular relation to the surfaces of the radial member.

Again referring primarily to Figures 2-6, particular embodiments of the sacroiliac
joint implant (6) can further include one or more aperture elements (31) which communicate

between the opposed faces (17)(18) of the first radial member (14) or the second radial member (15) or both. The amount of open space of an aperture element (31) can be defined by an aperture perimeter (32) which can be of numerous and varied configurations of sufficient dimension to allow the surfaces of the ilium (5) or sacrum (4)(or both) adjacent to the first radial member (14) or the second radial member (15)(or both) of the sacroiliac joint implant (6) to grow a distance into the aperture element (31) or through the aperture element (31) or fuse within the aperture element (31) or fuse into material placed within the aperture element, the material can include: osseointegratable, osteoinductive, osteoconductive, osteogenic materials or biologically active agents, or combinations and permutation thereof.

As a non-limiting example, the aperture perimeter (32) can be of generally oval configuration resulting in an oval aperture element (31) located in the first radial member (14) or the second radial member (15)(or both)(or located in additional radial members depending upon the embodiment) with the length of the oval aperture element (31) aligned with the length of the first radial member (14) or second radial member (15) and being about one quarter to about two thirds the length of the radial member and having a width of the oval aperture element (31) located between the sides (21)(22) of the first radial member (14) or second radial member (15) and being about one quarter to about two thirds the height (28a). Additionally, the elongate body (7) can further include aperture elements (31) which communicate between the external surfaces between the radial members (14)(15)(26)(27).

20

Again referring primarily to Figures 2-7, embodiments of the sacroiliac joint implant (6) can further include an anti-migration element (33) coupled to the first implant end (11) of the elongate body (7). The anti-migration element (33) can take the form of an enlarged terminal portion of the first end of the elongate body (7)(as shown in Figures 2-6), an increase in the height (28) of one or more of the radial members (such as flaring outward as shown in Figure 7) proximate the first implant end (11) of the elongate body (7). As one non-limiting example, the anti-migration element (33) can take the form of an end cap (34) having a generally circular configuration with the center substantially aligned with the longitudinal axis (8) of the elongate member (7) and extending radially outward sufficient distance to prevent advancement of the second implant end (12) of the sacroiliac joint implant (6) further into the sacroiliac joint (1) subsequent to implantation in the implant receiving space (29). While the end cap (34) shown is generally circular in configuration, the end cap (34) can have end cap perimeter (35) which defines an oval, square, rectangle, or other configuration useful in fixing the location of the sacroiliac joint implant (6) in relation the

sacroiliac joint (1). Additionally, the anti-migration element (33) can have sufficient dimensions to further include one or more bores (36) which communicate between the opposed surfaces (37)(38) of the anti-migration element (33) and dimensioned to receive mechanical fasteners (39)(such threaded members, barbed members, locking members or the like) which can be driven or rotated to engage a portion of the mechanical fastener with the sacrum (4) or the ilium (5). Now referring primarily to Figure 2, the anti-migration element (33) can also take the form of tapered elements on a part or the entirety of the external surface which taper outward from the surface allowing insertion of embodiments of the sacroiliac joint implant (6) but opposes backward travel. Now referring primarily to Figure 7, the anti-migration element (33) can take the form of tapered terminal end (33/99) of the sacroiliac joint implant (6) which resists forward or backward travel of the sacroiliac joint implant (6).

The elongate body (7) along with the other elements of the sacroiliac joint implant (6) above described can be fabricated or formed from a plurality of pieces or as a single piece of biocompatible material or a combination of biocompatible and biodegradable materials of suitably dimensioned particles, sheets, or other constructional forms or formable or moldable materials suitably bound or formed or molded to provide configurations in accordance with the invention.

Now referring primarily to Figures 8 and 9, embodiments of the sacroiliac joint implant (6) can further include a coat (40) coupled, generated or integral to all or a part of the external surface of the sacroiliac joint implant (6). The coat (40) can be of any composition that can be coupled to the sacroiliac joint implant (6) capable of biocompatible osseointegration with the bone of the ilium (5) and sacrum (4), such as pure alumina, titanium-dioxide, hydroxyapatite, calcium triphosphate, or the like. As a non-limiting example, the coat (40) can be applied by plasma spraying with a plasma torch, plasmatron or a plasma gun. Alternately, the coat (40) can be achieved by producing a surface roughness, porosity, or irregularity of the sacroiliac joint implant (6) by sand blasting, bead blasting, molding, or the like. The coat (40) can have a thickness in the range of about 40 μm and about 100 μm . Again, embodiments of the sacroiliac joint implant (6) can be configured as a material having interconnecting pores throughout such as TRABECULAR METAL available from Zimmer, P.O. Box 708, 1800 West Center Street, Warsaw, Indiana 46581-0708 or a metallic foam such as a titanium foam available from the National Research Council Canada, 1200 Montreal Road, Bldg. M-58, Ottawa, Ontario, Canada or fully-engineered, porous,

titanium structures such as TRABECULITE available from Tecomet, 115 Eames Street, Wilmington, MA 01887 .

Again referring primarily to Figure 2 and Figures 3-6, embodiments of the invention
5 can further include one or more biologically active agent(s) (41) which can be applied
directly to the external surface of the sacroiliac joint implant (6) or can be mixed with a
biocompatible material or biocompatible biodegradable material or biocompatible
osseointegratable material (collectively numeric indicator (100) which can be applied to the
external surface of the sacroiliac joint implant (6) or otherwise made a part of the sacroiliac
10 joint implant (6). As to particular embodiments of the fixation fusion implant (6), the
biologically active agent(s)(41) can be mixed with an amount of a biocompatible
biodegradable material or osseointegratable material (100) and located within one or more
of the aperture elements (31).

15 “Biocompatible” for the purposes of this invention means the ability of any material
to perform the intended function of an embodiment of the invention without eliciting any
undesirable local or systemic effects on the recipient and can include non-biodegradable
materials such as: ceramic; metals or steels such as titanium alloys or rigid polymeric
materials or rigid laminate materials or composites which include suitably dimensioned
20 particles of metals or steels dispersed within rigid laminate materials, or suitably sized
particles of biocompatible materials suitably bound or formed to provide configurations,
polyurethanes, polyisobutylene, ethylene-alpha-olefin copolymers, acrylic polymers and
copolymers, vinyl halide polymers and copolymers, polyvinyl esters, polyvinylidene
chloride, polyacrylonitrile, polyvinyl ketones, polyvinyl aromatics such as polystyrene,
25 copolymers of vinyl monomers and olefins such as ethylene-methyl methacrylate
copolymers, acrylonitrile-styrene copolymers, ABS resins, ethylene-vinyl acetate
copolymers, polyamides such as Nylon 66 and polycaprolactone, alkyd resins,
polycarbonates, polyoxyethylenes, polyimides, polyesters, epoxy resins, rayon-triacetate,
cellophane, polyether ether ketone (PEEK), polyetherketoneketone (PEKK), bone-from-wood
30 available from the Istituto di Scienza e Tecnologia dei Materiali Ceramici, Faenza, Italy, or
the like, or biodegradable materials, as herein described.

“Biodegradable” for the purposes of this invention means the ability of any
biocompatible material to breakdown within the physiological environment of the sacroiliac

joint by one or more physical, chemical, or cellular processes at a rate consistent with providing treatment of a condition of the sacroiliac joint at a therapeutic level controllable by selection of a polymer or mixture of polymers (also referred to as polymeric materials), including, but not limited to: polylactide polymers (PLA), copolymers of lactic and glycolic acids (PLGA), polylactic acid-polyethylene oxide copolymers, poly(ϵ -caprolactone-co-L-lactic acid (PCL-LA), glycine/PLA copolymers, PLA copolymers involving polyethylene oxides (PEO), acetylated polyvinyl alcohol (PVA)/polycaprolactone copolymers, hydroxybutyrate-hydroxyvalerate copolymers, polyesters such as, but not limited to, aspartic acid and different aliphatic diols, poly(alkylene tartrates) and their copolymers with polyurethanes, polyglutamates with various ester contents and with chemically or enzymatically degradable bonds, other biodegradable nonpeptidic polyamides, amino acid polymers, polyanhydride drug carriers such as, but not limited to, poly(sebacic acid) (PSA), aliphatic-aromatic homopolymers, and poly(anhydride-co-imides), poly(phosphoesters) by matrix or pendant delivery systems, poly(phosphazenes), poly(iminocarbonate), crosslinked poly(ortho ester), hydroxylated polyester-urethanes, or the like.

“Biologically active agents” for the purposes of this invention means those agents or mixture of agents which can be varied in kind or amount to provide a therapeutic level effective to mediate the formation or healing of bone, cartilage, tendon, or to reduce, inhibit, or prevent a symptom of a condition of the sacroiliac joint subsequent to placement of an embodiment of the fixation fusion implant within the sacroiliac joint (1) such as infection or pain and without limitation can include agents that influence the growth of bone, demineralized bone matrix, stem cells, allografts, autografts, xenografts, bone forming protein whether naturally occurring, synthetic, or recombinant, growth factors, cytokines, bone morphogenetic protein 2, bone morphogenetic protein 7, analgesics, anesthetics, anti-inflammatory agents, antibacterials, antivirals, antifungals, antiprotozoals, anti-infectives, antibiotics such as aminoglycosides such as gentamicin, kanamycin, neomycin, and vancomycin; amphenicols such as chloramphenicol; cephalosporins, such as cefazolin HCl; penicillins such as ampicillin, penicillin, carbenicillin, oxycillin, methicillin; lincosamides such as lincomycin; polypeptide antibiotics such as polymixin and bacitracin; tetracyclines such as tetracycline, minocycline, and doxycycline; quinolones such as ciprofloxacin, moxifloxacin, gatifloxacin, and levofloxacin; anti-viral drugs such as acyclovir, gancyclovir, vidarabine, azidothymidine, dideoxyinosine, dideoxycytosine; analgesics, such as codeine, morphine, ketorolac, naproxen, an anesthetic, lidocaine; cannabinoids; antifungal agents such

as amphotericin; anti-angiogenesis compounds such as anecortave acetate; retinoids such as tazarotene, steroidal anti-inflammatory agents such as 21-acetoxypregnenolone, alclometasone, algestone, amcinonide, beclomethasone, betamethasone, budesonide, chloroprednisone, clobetasol, clobetasone, clocortolone, cloprednol, corticosterone, cortisone, cortivazol, deflazacort, desonide, desoximetasone, dexamethasone, diflorasone, diflucortolone, difluprednate, enoxolone, fluazacort, flucloronide, flumethasone, flunisolide, fluocinolone acetonide, fluocinonide, fluocortin butyl, fluocortolone, fluorometholone, fluperolone acetate, fluprednidene acetate, fluprednisolone, flurandrenolide, fluticasone propionate, formocortal, halcinonide, halobetasol propionate, halometasone, halopredone acetate, hydrocortamate, hydrocortisone, loteprednol etabonate, mazipredone, medrysone, meprednisone, methylprednisolone, mometasone furoate, paramethasone, prednicarbate, prednisolone, prednisolone 25-diethylamino-acetate, prednisolone sodium phosphate, prednisone, prednival, prednylidene, rimexolone, tixocortol, triamcinolone, triamcinolone acetonide, triamcinolone benetonide, triamcinolone hexacetonide; or allograft cellular matrix containing viable mesenchymal stem cells such as OSTEOCEL PLUS available from NuVasive, Inc., 7475 Lusk Blvd., San Diego, CA 92121 USA, and any of their derivatives, whether separately or in combinations thereof.

As to particular embodiments of the inventive fixation fusion implant (6) the biologically active agent(s)(41) can be dispersed throughout a biocompatible or biocompatible biodegradable material (or mixture of biocompatible materials or mixture of biocompatible biodegradable materials) by mixing biologically active agent(s)(41) into the melted biocompatible or biodegradable polymer and then solidifying the resulting material by cooling, having the biologically active agent(s)(41) substantially uniformly dispersed throughout. The biodegradable material or biocompatible material or mixture thereof can be selected to have a melting point that is below the temperature at which the biologically active agent(s)(41) becomes reactive or degrades. Alternatively, the biologically active agent(s)(41) can be dispersed throughout the biocompatible or biodegradable material by solvent casting, in which the biocompatible or biodegradable material is dissolved in a solvent, and the biologically active agent(s)(41) dissolved or dispersed in the solution. The solvent is then evaporated, leaving the biologically active agent(s)(41) in the matrix of the biocompatible or biodegradable material. Solvent casting requires that the biocompatible or biodegradable material be soluble in organic solvents. Alternatively, the fixation fusion implant (6) can be placed in a solvent having a concentration of the biologically active agent(s)(41) dissolved

and in which the fixation fusion implant (6) or the biocompatible or biocompatible biodegradable material located in the aperture elements, or applied to the external surface, swells. Swelling of the fixation fusion implant (6) or portions thereof draws in an amount of the biologically active agent(s) (41). The solvent can then be evaporated leaving the
5 biologically active agent(s)(41) within the biocompatible or biocompatible biodegradable material. As to each method of dispersing the biologically active agent(s) (41) through out the biocompatible or biodegradable biocompatible material of or coupled to the fixation fusion implant (6), therapeutic levels of biologically active agent(s)(41) can be included in biocompatible biodegradable material to provide therapeutically effective levels of the
10 biologically active agent to the sacroiliac joint (1) to treat a particular sacroiliac joint condition.

Other non-active agents (42) may be included in the biocompatible biodegradable material for a variety of purposes. For example, buffering agents and preservatives may be
15 employed. Preservatives which may be used include, but are not limited to, sodium bisulfite, sodium bisulfate, sodium thiosulfate, benzalkonium chloride, chlorobutanol, thimerosal, phenylmercuric acetate, phenylmercuric nitrate, methylparaben, polyvinyl alcohol and phenylethyl alcohol. Examples of buffering agents that may be employed include, but are not limited to, sodium carbonate, sodium borate, sodium phosphate, sodium acetate, sodium
20 bicarbonate, and the like, as approved by the FDA or other appropriate agencies in the United States or foreign countries, for the desired route of administration. Electrolytes such as sodium chloride and potassium chloride may also be included in the formulation.

A non-limiting example, embodiments of the fixation fusion implant (6) having a
25 biocompatible biodegradable portion with biologically active agent(s)(41) for treating the sacroiliac joint (1) can be made by dispersing a biologically active agent(s)(41) in a biocompatible biodegradable material as above described to provide biologically active agent(s) (41) release characteristics at a therapeutic level. Upon implantation of the fixation fusion implant (6) in the sacroiliac joint (1) as described below, the biocompatible
30 biodegradable portion of the fixation fusion implant (6) can substantially continuously release biologically active agent (41) to provide a localized amount of bone morphogenetic protein 2 at therapeutic levels of about 1 milligram to about 4 milligrams to facilitate bone regrowth. It is to be understood that this specific example of providing an embodiment of the fixation fusion implant (6) which delivers an amount of bone morphogenetic protein 2 to facilitate

bone regrowth, is not intended to be limiting, and embodiments of the fixation fusion implant (6) can be utilized to deliver numerous and varied active agent(s)(41) individually or in combination to treat a wide range of conditions of the sacroiliac joint (1) subsequent to implantation of embodiments of the fixation fusion implant (6).

5

Now referring primarily to Figures 10-15 and 30, particular embodiments of the invention can further include an amount of curvature (43) between the first implant end (11) and the second implant end (12) of the fixation fusion implant (6). The amount of curvature (43) can vary from embodiment to embodiment of the fixation fusion implant (6) depending on the application between a substantially linear elongate body (7) as above described to including an amount of curvature (43) which defines a radius to facilitate placement in the cranial portion (87) and a caudal portion (86) between the articular surfaces (16) of the sacroiliac joint (1) or in the corresponding implant receiving space (29). As one non-limiting embodiment the radius can be within a range of about 2 cm and about 6 cm.

15

Now referring primarily to Figure 15, certain embodiments of the invention having an amount of curvature can be provided in a plurality of implant segments (101)(102)(103) which can be individually implanted within the articular region (44) as shown in Figure 25, 27, or 29 by the method below described.

20

Additionally, embodiments of the sacroiliac joint implant (6) can be configured to house a bone growth stimulator (105). Useful implantable growth stimulators can directly engage the anode of a battery and a single or double titanium cathode wire implanted within or in close proximity to the sacroiliac joint implant (6). The cathode wire can be disposed a distance into the host bone, bone graft, or portions of the device, preferably with the cathode ends contacting and or anchored into living bone. Embodiments of the invention can include a metal implant with an insulation material, such as PEEK, to prevent cathode-metal contact, while permitting cathode-bone contact. The battery can be placed in an extrafascial, subcutaneous pocket for removable placement. A suitable growth stimulator is available from Biomet Trauma 100 Interpace Pkwy # 1, Parsippany, NJ 07054-1149.

25
30

Understandably, a plurality of inventive sacroiliac joint implants (6) whether separately or in joined relation, whether the same or different embodiments, can be utilized with conventional or the inventive methods of implantation herein described for fixation and

fusion of the sacroiliac joint (1). As one example, a plurality of elongate bodies (7) can be joined in fixed, substantially fixed or movable relation to provide an embodiment of the sacroiliac joint implant (6).

5 Now referring primarily to Figures 16-24, a non-limiting method of accessing an articular region (44) between the articulating surfaces (16) of the sacroiliac joint (1) and placing a sacroiliac joint implant (6) non-transversely between the articulating surfaces (16) within the articular region (44) of the sacroiliac joint (1) to dispose the sacrum (4) and the ilium (5) in substantially immobilized relation by corresponding engagement of the sacroiliac
10 joint implant (6) by the articulating surfaces (16) of the sacroiliac joint (1). The particular example of the method described is sufficient to enable a person of ordinary skill in the art to utilize embodiments of the sacroiliac joint implant (6) and is not intended to be limiting with respect to the order of steps or the use of all or any of the steps or combination of one or more steps into one steps or performing any one step as substeps, or other similar, equivalent, or
15 conventional steps to implant embodiments of the sacroiliac joint implant within the sacroiliac joint. (1).

 Now referring primarily to Figure 16, an embodiment of the method can include the step of placing a patient under sedation prone on a translucent operating table (or other
20 suitable surface). The sacroiliac joint (1) can be locally anesthetized to allow for injecting a radiographic contrast (46) (as a non-limiting example, Isovium 300 radiographic contrast) under fluoroscopic guidance into the inferior aspect of the sacroiliac joint (1) to outline the articular surfaces (16) of the sacroiliac joint (1). Injection of the radiographic contrast (46) within the sacroiliac joint (1) can be accomplished utilizing a tubular member (47)(such as a
25 syringe needle) having first tubular member end (48) which can be advanced between the articulating surfaces (16) of the sacroiliac joint (1) and having a second tubular member end (49) which removably couples to a hub (50). The hub (50) can be configured to removably couple to a syringe barrel (51)(or other device to contain and deliver an amount of radiographic contrast (46)). In the example of a syringe barrel (51), the syringe barrel (51)
30 can have an internal volume capable of receiving an amount of the radiographic contrast (46) sufficient for outlining the lateral articular surfaces (16) of the sacroiliac joint (1). A plunger (52) can be slidingly received within the barrel (51) to deliver the radiographic contrast (46) through the tubular member (47) into the sacroiliac joint (1). The tubular member (47) can have a gauge in the range of about 16 gauge and about 20 gauge and can further be

incrementally marked on the external surface to allow determination of the depth at which the first needle end (48) has advanced within the sacroiliac joint (1). As the first needle end (48) advances into the sacroiliac joint (1) the radiographic dye (46) can be delivered from within the syringe barrel (51) into the sacroiliac joint (1) to allow visualization of the sacroiliac joint (1) and location of the tubular needle (47) within the sacroiliac joint (1).

Now referring primarily to Figure 17, once the first tubular member end (48) has been sufficiently advanced into the sacroiliac joint (1) and the articular surfaces (16) of the sacroiliac joint (1) have been sufficiently visualized, the hub (50) can be removed from the tubular member (47) leaving the tubular member (47) fixed within the sacroiliac joint (1) as a initial guide for tools subsequently used to locate or place the sacroiliac joint implant (6) non-transversely between the articulating surfaces (16) of the sacroiliac joint (1) or in removal of a portion of the sacroiliac joint (1) within the region defined by the articular surfaces (16) to generate an implant receiving space (29). Alternately, one or more guide pins (13) can be inserted along substantially the same path of the tubular member (47) for fixed engagement within the sacroiliac joint (1) and used in subsequent steps as a guide(s).

Now referring primarily to Figures 18, a small incision can be made in the skin at the posterior superior (or as to certain embodiments inferior) aspect of the sacroiliac joint (1), extending proximal and distal to the tubular member (47) along the line of the sacroiliac joint (1) to provide a passage to access the interarticular space between the articulating surfaces (16) of the sacroiliac joint (1). A cannulated probe (53) can be slidingly engaged with the tubular member (47)(or guide pin (13)) extending outwardly from the sacroiliac joint (1) (while the sacroiliac joint may be shown in the figures as being substantially linear for illustrative purposes, it is to be understood that the normal irregular features of the sacroiliac joint have not been removed). The cannulated probe (53) can have a probe body (54) of generally cylindrical shape terminating in a spatulate tip (55) at the end advanced into the sacroiliac joint (1). A removable cannulated probe handle (56) couples to the opposed end of the probe body (54). The spatulate tip (55) can be guided along the tubular needle (47)(or guide wire (13) into the posterior portion of the sacroiliac joint (1) and advanced to the anterior portion of the sacroiliac joint (1) under lateral fluoroscopic visualization. The cannulated probe handle (56) can then be removed providing the generally cylindrical probe body (54) extending outwardly from the sacroiliac joint (1) through the incision made in the skin.

Now referring primarily to Figure 19, a passage from the incision to the sacroiliac joint (1) can be generated by inserting a cannula (57) into the incision. A soft tissue dilator (58) having a blunt end (59) can be advanced over the probe body (54), or a plurality of soft tissue dilators of increasing size, until the blunt end (59) of the soft tissue dilator (58) and the corresponding cannula end (45) contact the posterior aspect of the sacroiliac joint (1). The soft tissue dilator (58) can be removed from within the cannula (57). The external surface of the cannula (57) can be sufficiently engaged with the surrounding tissue to avoid having the tissue locate within the hollow inside of the cannula (57). A non-limiting embodiment of the cannula (57) provides a tubular body having substantially parallel opposed side walls which terminate in a radius at both ends (lozenge shape) into which a plurality of different jigs can be inserted.

Now referring primarily to Figure 20A-20C, a cannula alignment jig (60) can be advanced over the probe body (54)(or guide pins (13)) and received within the cannula (57). Substantially, identical cross hairs (63)(64) can be disposed on the upper jig surface (65) and the lower jig surface (66). Alignment of the cross hairs (63)(64) under x-ray with the sacroiliac joint (1) can confirm that the cannula (57) has proper orientation in relation to the paired articular surfaces (16) of the sacroiliac joint (1). The cannula (57) properly oriented with the paired articular surfaces (16) can then be disposed in fixed relation to the sacroiliac joint by placement of fasteners through the cannula (57) into the sacrum (4) or the ilium (5).

Now referring to Figure 21A and 21B, a first drill jig (67) can be advanced over the probe body (54)(or guide pins (13)) and received within the cannula (57). The probe body (54)(or guide pins (13)) extending outwardly from the sacroiliac joint (1) passes through a drill guide hole (68) of the first drill jig (67)(or a plurality of guide pins (13) can extend through a corresponding plurality of guide pin holes (69)). The drill guide hole (68) can take the form of a circular hole as shown in the Figures, a slot, or other configuration to restrict the movement of the drill bit (62) within the drill jig (67) and provide a guide for a drill bit (62) in relation to the sacroiliac joint (1).

Now referring to Figure 22, a cannulated drill bit (70) can be advanced over the probe body (54) and within a drill guide hole (68) of the first drill jig (67). The cannulated drill bit (70) under fluoroscopic guidance can be advanced into the interarticular region (44) between

the articulating surfaces (16) of the sacroiliac joint (1) to produce a first bore (71)(shown in broken line) to a determined depth. As to certain embodiments of the method, an amount of articular cartilage or other tissues from between the articular surfaces (16) of the sacroiliac joint (1) can be removed sufficient to allow embodiments of the sacroiliac joint implant (6) to be implanted in replacement of the removed articular cartilage or tissue. Because the method removes the degenerative articular cartilage or tissue between the articular surfaces (16) of the sacroiliac joint (1), the articular surfaces (16) of the sacroiliac joint (1) can remain intact or substantially intact allowing the sacroiliac joint implant (6) to be non-transverely located between the articular surfaces (16) of the sacroiliac joint (1). Understandably, other instruments can be utilized separately or in combination with a cannulated drill bit (62) for the removal of articular cartilage or tissue between articular surfaces (16) such as: box chisels, burs, hole saws, curettes, lasers (such as CO₂, Neodymium/YAG (yttrium-aluminum-garnet), argon, and ruby), electrosurgical equipment employing electromagnetic energy (the cutting electrode can be a fine micro-needle, a lancet, a knife, a wire or band loop, a snare, an energized scalpel, or the like) where the energy transmitted can be either monopolar or bipolar and operate with high frequency currents, for example, in the range of about 300kHz and about 1000 kHz whether as pure sinusoidal current waveform where the "crest factor" can be constant at about 1.4 for every sinus waveform, and a voltage peak of approximately 300 V to enable a "pure" cutting effect with the smallest possible coagulation effect or as amplitude modulated current waveforms where the crest factor varies between 1.5 and 8, with decreasing crest factors providing less of a coagulation effect. Electrosurgical waveforms may be set to promote two types of tissue effects, namely coagulation (temperature rises within cells, which then dehydrate and shrink) or cut (heating of cellular water occurs so rapidly that cells burst). The proportion of cells coagulated to those cut can be varied, resulting in a "blended" or "mixed" effect. Additionally, a fully rectified current, or a partially rectified current, or a fulguration current where a greater amount or lateral heat is produced can be employed to find the articular surfaces of the joint and aid in advancing a probe or guide wire into a position in between the articulating surfaces. These currents can effectively degrade the cartilage and allow advance into the joint without grossly penetrating much beyond the cartilage.

Now referring to Figure 23, as to certain embodiments of the invention, the first drill jig (67) can be removed from within the cannula (57) and a second drill jig (72) can be advanced over the probe body (54) and received within the cannula (57); however, the

invention is not limited to any particular number of drill jigs and as to certain embodiments of the method the first drill jig (67) can include all the required drill guide hole(s) (68)(or slots or other configurations of the drill guide) and as to other embodiments of the method a plurality of drill jigs can be utilized in serial order to provide all the drill guide holes (68). As to the particular embodiment of the invention shown by the Figures, the first drill jig (67) can provide one or more additional drill guide holes (68) which guide in relation to the first bore (71) a second or more cannulated drills (62) of the same or different configuration to be inserted within and advanced into the sacroiliac joint (1) to produce a second bore (73)(generally shown in broken line as 71/73) or a plurality of bores within the sacroiliac joint (1) spaced apart in predetermined pattern to allow removal of sufficient articular cartilage (16) or other tissue from the interarticular space of sacroiliac joint (1) for placement of embodiments of the sacroiliac joint implant (6) within the region defined by and between the paired articular surfaces (16) of the sacroiliac joint (1). As to certain methods of the invention, the first drill jig (67) or the second drill jig (72) or a plurality of drill jigs can be utilized in serial order to remove a portion of the sacroiliac joint (1) for generation of an implant receiving space (29). As these embodiments of the method, articular cartilage or other tissues and sufficient subchondral bone can be removed from between the articular surfaces (16) of the sacroiliac joint (1) sufficient to allow placement of certain embodiments of the sacroiliac joint implant (6) and one or more radial member receiving channels (74) can be cut into at least one of the articular surfaces (16) of said sacroiliac joint (1) sufficient to receive other embodiments of the sacroiliac implant (6). The one or more radial member receiving channels (74) can be cut a depth into the subchondral, cortical bone or cancellous bone of the sacrum (4) or ilium (5).

Now referring primarily to Figure 24, in a subsequent step, the last in the serial presentation of drill jigs (67)(72) can be removed from within the cannula (57) and a broach jig (75) can be advanced over the probe body (54) to locate within the cannula (57). The broach jig (75) can include a broach guide hole (76) which receives a first broach end (77) of a cannulated broach (78) advanced over the probe body (54). The first broach end (77) can have a configuration which can be advanced into the sacroiliac joint (1). As to certain embodiments of the method, the first broach end (77) can be adapted to remove an amount of articular cartilage and other tissue from the between the articular surfaces (16) within th articular region (44) of the sacroiliac joint (1) for non-transverse placement of a sacroiliac joint implant (6) having an elongate body (7), or having an elongate body (7) and a first radial

member (14), or an elongate body (7) having a first and second radial members (14)(15) between the articular surfaces (16) of the sacroiliac joint (1). As to other embodiments of the method, the cannulated broach (78) can remove a sufficient a portion of the sacroiliac joint (1) to generate an implant receiving space (29) to receive embodiments of the sacroiliac joint implant (6) having an elongate body (7), an elongate body (7) and at least one radial member (14) adapted for non-transverse placement between the articular surfaces (16) or at least one radial member (26) adapted to extend into the bone of the sacrum (4) or the ilium (5). As a non-limiting example, Figure 24 shows a broach (78) configured to remove a portion of the sacroiliac joint (1) to produce a implant receiving space (29) to receive embodiments of the sacroiliac joint implant (6) having and elongate body (7) to which a first radial member (14) and a second radial member (15) extend along the longitudinal axis (8) of the elongate body (7) in substantially opposed relation adapted to locate between the articular surfaces (16) of the sacroiliac joint (1) and further having a third radial member (26) and a fourth radial member (27) which extend along the longitudinal axis (8) of the elongate member (7) in substantially opposed relation adapted to correspondingly extend correspondingly into the bone of the sacrum (4) and the ilium (5).

Now referring primarily to Figures 25 and 26A, 26B, and 26C, the implant receiving space (29) and the sacroiliac joint implant (6) can be configured having related dimension relations such that placement of the sacroiliac joint implant (6) within the implant receiving space (29) disposes the sacrum (4) and the ilium (5) in substantially immobilized relation and substantially avoids alteration of the positional relation of the sacrum (4) and the ilium (5) from the normal condition, or avoids driving together or driving apart the sacrum (4) from the ilium (5) outside of or substantially outside of the normal positional relation. An intention in selecting configurations of the sacroiliac joint implant (6) and the implant receiving space (29) being immobilization of the sacrum (4) in relation to the ilium (5) while maintaining the sacroiliac joint (1) in substantially normal or substantially normal positional relation, or returning the sacroiliac joint (1) to a substantially normal positional relation to correct a degenerative condition of the sacroiliac joint (1).

As a non-limiting example, configurations of an implant receiving space (29) allow embodiments of the sacroiliac joint implant (6) to be placed non-transversely between the caudal portion (86) of the articular surfaces (16) of the sacroiliac joint (1). While certain embodiments of the sacroiliac joint implant (6) may only provide an elongate body (7) which

locates within a correspondingly configured implant receiving space (29) to engage at least a portion of the bone of the ilium (5); the invention is not so limited, and can further include at least a first radial member or a first and a second radial member at least a portion of the external surface of the first radial member (14) engaging a portion of the bone (73) of the sacrum (4) and the ilium (5). As to those embodiments of the sacroiliac joint implant (6) which have a third radial member (26) and a fourth radial member (27) the implant receiving space (29) an further include one more radial member receiving channels (74)) which correspondingly allow the third and fourth radial members (26)(27) to extend into the bone of the sacrum (4) or the ilium (5)(whether subchondral, cortical, cancellous, or the like), or impact of the sacroiliac joint implant (6) into the implant receiving space (29) without the radial member receiving channels (74) can forcibly urge the radial members (26)(27) into the bone of the sacrum (4) and the ilium (5). Mechanical fasteners (39)(such as treaded members) can be inserted through the bores (36) in the anti-migration element (33) and into the sacrum (4) and ilium (5) to fix location of the fixation fusion implant (6) within the implant receiving space (29).

Now referring to Figures 27 and 28A, 28B and 28C, as second a non-limiting example, configurations of an implant receiving space (29) allow embodiments of the sacroiliac joint implant (6) to be placed non-transversely between the cranial portion (86) of the articular surfaces (16) of the sacroiliac joint (1) by the similar procedures or steps as above described with the incision and generation of the passage to the superior articular portion of the sacroiliac joint (1).

Now referring to Figures 29 and 30, configurations of an implant receiving space (29) allow embodiments of the sacroiliac joint implant (6) to be placed non-transversely between the cranial portion (87) and caudal portion (86) of the articular surfaces (16) of the sacroiliac joint (1) by the similar procedures or steps as above described with the incision and generation of the passage to the inferior articular portion of the joint.

Now referring primarily to Figure 31, which shows an embodiment of the sacroiliac joint implant (6) having a portion of the axial bore (9) adapted to fixedly mate with a portion of an alignment tool (79). The alignment tool (79) can have a fixed or adjustably fixed configuration which aligns a cannulated alignment guide (80) with one of the bores (36) through the sacroiliac joint implant (6). An insertion tool (81) can be slidingly engaged with

the cannulated alignment guide (80). An elongate member (85) can be removably fixedly attached to the first insertion tool end (82) proximate the bore (36) in the sacroiliac joint implant (6). The second insertion tool end (83) can be forcibly advanced in the cannulated alignment guide (80) to advance the elongate member (81) to pass through the bore (36) to
5 dispose the elongate member (81) in transverse relation to said articular surfaces (16) correspondingly engaged with sacroiliac joint implant (6). As a non-limiting example, the elongate member (81) can have a spiral thread (84) coupled to the external surface and by rotation of the second end (83) of the insertion tool (81) the elongate member (85) can be drawn through the bore (36) of the sacroiliac joint implant (1) in transverse relation to said
10 articular surfaces (16) correspondingly engaged with sacroiliac joint implant (6). By further operation of the elongate member (85) the articular surfaces (16) of the sacroiliac joint (1) can be drawn against the external surfaces of the sacroiliac joint implant (6).

Now referring primarily to Figure 32, embodiments of the invention can further
15 comprise a coupling element (87) connected to the first end (11) of the sacroiliac joint implant (6). As a non-limiting example, the coupling element (87) can be disposed in fixed relation to the first end (11) of the sacroiliac joint implant (6) by threaded engagement of a fastener portion (88); however, the invention is not so limited and the fastener portion (88) can be connected to the first end (11) of the sacroiliac joint implant (6) by any method such
20 as welding, spin welding, adhesive, or the like. The coupling element (87) can further provide a coupling portion (89) configured to join with a numerous and wide variety of cross sectional geometries of spanning members (90). As a non-limiting example, the coupling portion (89) can be configured as cylindrical cup (91) pivotally coupled to the fastener portion (88). A spiral thread can be coupled to the internal surface of the cylindrical cup (91)
25 to rotationally receive a spirally threaded body (92). The side wall (93) of the cylindrical cup (91) can include a pass through element (94) in which part of a spanning member (90) can be received. The part of the spanning member (90) received within the pass through element (94) can be placed in fixed relation to the cylindrical cup (91) by rotational engagement of the spirally threaded body (92).

30

Now referring primarily to Figure 33, as a further non-limiting example, each of a pair of sacroiliac joints (1) can receive an embodiment of the sacroiliac joint implants (6), above-described, each having a coupling element (87) coupled to the first end (11). Each of the coupling elements (87) can receive the opposed ends (95) of a spanning member (90).

Additionally, the spanning member (90) in fixed relation to the sacroiliac joint implants (6) can be connected to a plurality of additional spanning members (96) which can as a non-limiting example be placed in positional relation to the vertebral column (97) to allow support of additional implants which can be anchored between vertebrae.

5

Now referring primarily to Figure 34, as a further non-limiting example, a first coupling element (87) can be joined to the first end (11) of an embodiment of a sacroiliac joint implant (6) as above described and the fastener portion (88) of a second coupling element (87) can be disposed directly into the bone of the sacrum (4) or the ilium (5), or both.

10 The opposed ends (95) of a spanning element (90) in the form of a flat plate can be can provide apertures (96) through which the fastener portion (88) of the coupling element (87) can pass. The corresponding parts of the external surface of the coupling portion (89) and the spanning member (90) can be engaged to fix the location of the spanning member (90) allowing for coupling of the lumbar spine to the stabilized pelvis by a plurality of fixation

15 elements to further increase stability.

The method can further employ the use of intraoperative neurophysiological monitoring to reduce the risk to the patient of iatrogenic damage to the nervous system, particularly the peripheral nerves, or to provide functional guidance to the surgeon.

20

EXAMPLE 1.

An embodiment of the inventive sacroiliac joint implant having a configuration substantially as shown by Figures 3-6 and as above-described was inserted into a patient

25 under direct visualization and with assisted lateral fluoroscopy. The procedure was performed for the purpose of assessing in an actual reduction to practice the ability of the inventive sacroiliac joint implant to be safely implanted between inferior or caudal portion the articular surfaces of the sacroiliac joint substantially as shown in Figures 25 to confirm the that implantation of the sacroiliac joint implant into a implant receiving space configured

30 substantially as above-described acts to immobilize the sacroiliac joint. The sacroiliac joint implant as above-described implanted into the inferior (caudal) portion of the sacroiliac joint proved to immediately immobilize the sacroiliac joint.

As can be easily understood from the foregoing, the basic concepts of the present invention may be embodied in a variety of ways. The invention involves numerous and varied embodiments of sacroiliac joint fusion system which includes sacroiliac joint implants and methods of implanting the sacroiliac joint implants including the best mode to provide
5 fixation and fusion of the sacroiliac joint.

As such, the particular embodiments or elements of the invention disclosed by the description or shown in the figures or tables accompanying this application are not intended to be limiting, but rather exemplary of the numerous and varied embodiments generically encompassed by the invention or equivalents encompassed with respect to any particular
10 element thereof. In addition, the specific description of a single embodiment or element of the invention may not explicitly describe all embodiments or elements possible; many alternatives are implicitly disclosed by the description and figures.

It should be understood that each element of an apparatus or each step of a method may be described by an apparatus term or method term. Such terms can be substituted where
15 desired to make explicit the implicitly broad coverage to which this invention is entitled. As but one example, it should be understood that all steps of a method may be disclosed as an action, a means for taking that action, or as an element which causes that action. Similarly, each element of an apparatus may be disclosed as the physical element or the action which that physical element facilitates. As but one example, the disclosure of "an implant" should be
20 understood to encompass disclosure of the act of "implanting" -- whether explicitly discussed or not -- and, conversely, were there effectively disclosure of the act of "implanting", such a disclosure should be understood to encompass disclosure of "an implant" and even a "means for implanting a member." Such alternative terms for each element or step are to be understood to be explicitly included in the description.

In addition, as to each term used it should be understood that unless its utilization in
25 this application is inconsistent with such interpretation, common dictionary definitions should be understood to included in the description for each term as contained in the Random House Webster's Unabridged Dictionary, second edition.

For the purposes of the present invention, ranges may be expressed herein as from "about" one particular value to "about" another particular value. When such a range is expressed, another embodiment includes from the one particular value to the other particular value. Similarly, when values are expressed as approximations, by use of the antecedent
5 "about," it will be understood that the particular value forms another embodiment. It will be further understood that the endpoints of each of the ranges are significant both in relation to the other endpoint, and independently of the other endpoint. Moreover, the term "about" means as to any numeric value a deviation about that numeric value of up to ten percent.

10 Moreover, for the purposes of the present invention, the term "a" or "an" entity refers to one or more of that entity; for example, "a member" or "an elongate member" refers to one or more member(s) or at least one member. As such, the terms "a" or "an", "one or more" and "at least one" can be used interchangeably herein.

15 Thus, the applicant(s) should be understood to claim at least: i) the sacroiliac joint implants as herein disclosed and described, ii) the related methods disclosed and described, iii) similar, equivalent, and even implicit variations of each of these devices and methods, iv) those alternative embodiments which accomplish each of the functions shown, disclosed, or described, v) those alternative designs and methods which accomplish each of the functions
20 shown as are implicit to accomplish that which is disclosed and described, vi) each feature, component, and step shown as separate and independent inventions, vii) the applications enhanced by the various systems or components disclosed, viii) the resulting products produced by such systems or components, ix) methods and apparatuses substantially as described hereinbefore and with reference to any of the accompanying examples, x) the
25 various combinations and permutations of each of the previous elements disclosed.

The background section of this patent application provides a statement of the field of endeavor to which the invention pertains. This section may also incorporate or contain paraphrasing of certain United States patents, patent applications, publications, or subject
30 matter of the claimed invention useful in relating information, problems, or concerns about the state of technology to which the invention is drawn toward. It is not intended that any United States patent, patent application, publication, statement or other information cited or incorporated herein be interpreted, construed or deemed to be admitted as prior art with respect to the invention.

While specific embodiments have been described and illustrated, such embodiments should be considered illustrative only and not as limiting the invention as defined by the accompanying claims.

5

THE SUBJECT-MATTER OF THE INVENTION FOR WHICH AN EXCLUSIVE PROPERTY OR PRIVILEGE IS CLAIMED IS DEFINED AS FOLLOWS:

1. A system for fixating a sacroiliac joint, the system comprising:
 - a sacroiliac joint implant for implantation in the sacroiliac joint, the sacroiliac joint implant comprising an elongate body including a first end, a second end, a length disposed between the first end and the second end, and a rectilinear cross-section transverse to the length, the elongate body being adapted to non-transversely locate within the sacroiliac joint;
 - a first coupling element configured to connect to the sacroiliac joint implant;
 - a spanning member securable to the first coupling element; and
 - a second coupling element engageable with the spanning member.
2. The system as described in claim 1, wherein at least a portion of the spanning member is in the form of a plate, the portion configured with at least one aperture configured to allow passage of at least a part of the second coupling element.
3. The system as described in claim 2, wherein the second coupling element includes a fastener element configured to pass through an aperture and the fastener element is further configured to be disposed into bone of at least one of a sacrum and an ilium.
4. The system as described in any one of claims 1 to 3, wherein the system is configured to allow for coupling of a lumbar spine to a pelvis.
5. The system as described in any one of claims 1 to 3, wherein the system is configured to allow for coupling of a pair of sacroiliac joint implants.
6. The system as described in any one of claims 1 to 5, wherein at least two of the following form a unitary construction: the implant; the first coupling element; the second coupling element; and the spanning member.

7. The system as described in any one of claims **1 to 6**, wherein the rectilinear cross-section comprises a cross-shaped cross-section.
8. The system as described in any one of claims **1 to 6**, wherein the rectilinear cross-section comprises a triangular cross-section.

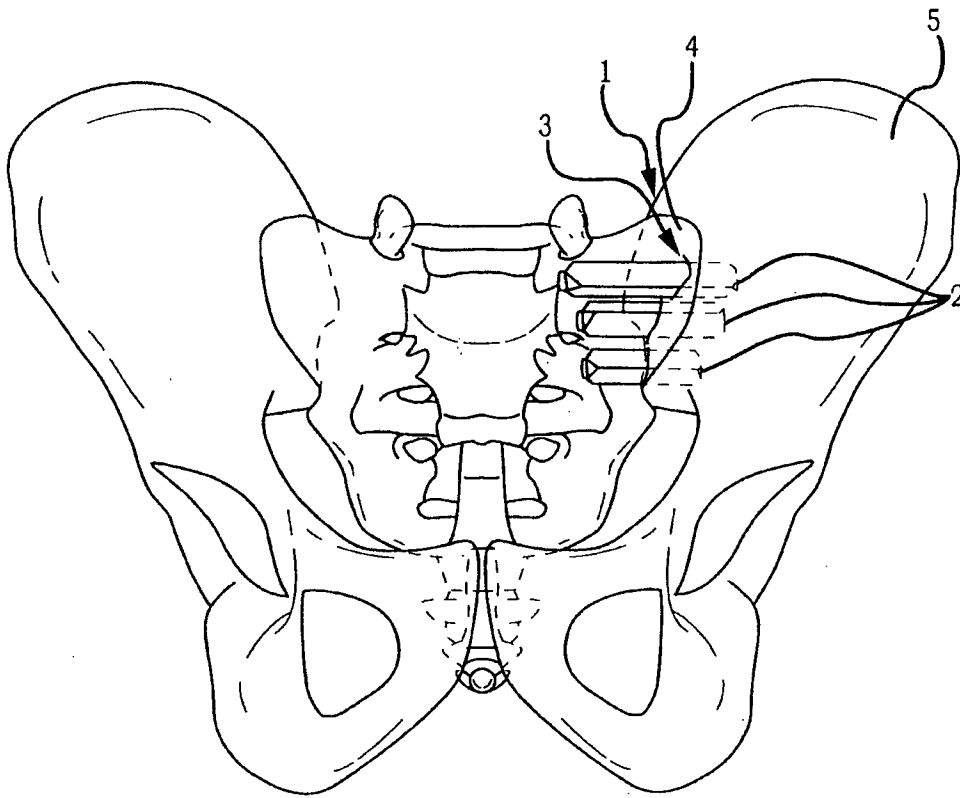
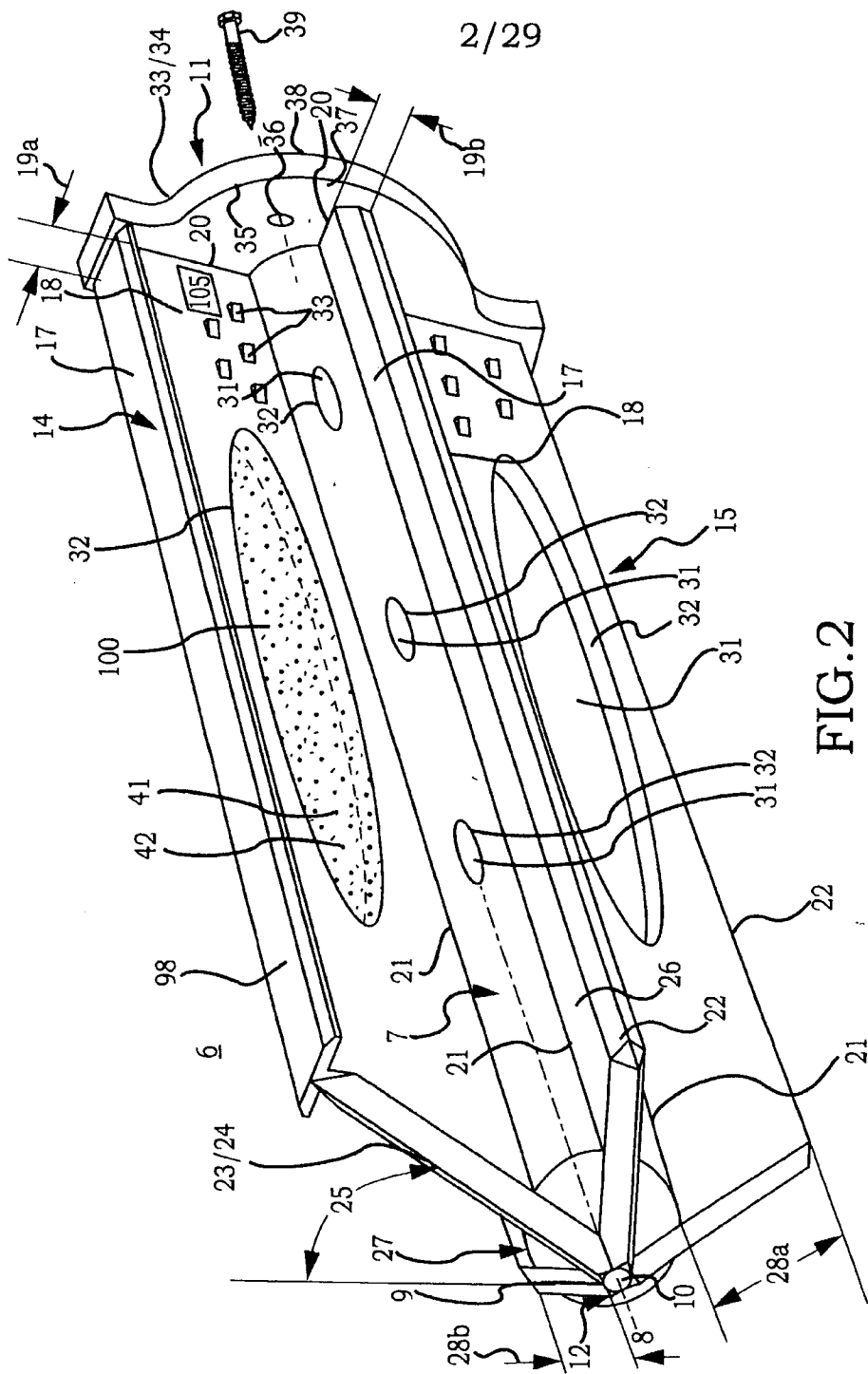
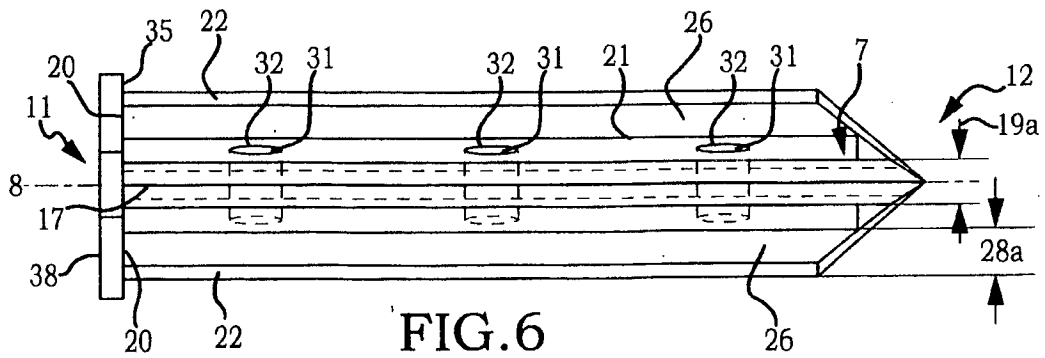
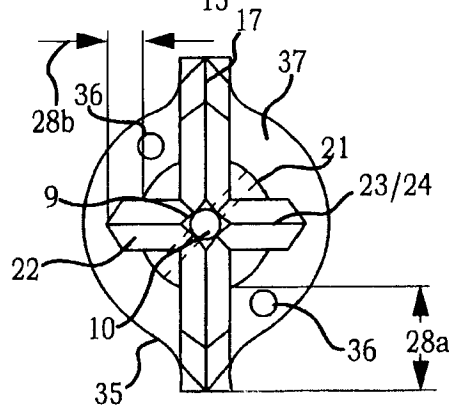
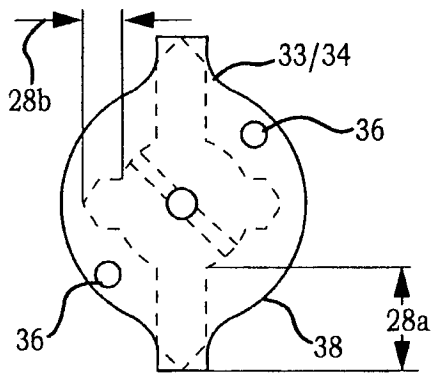
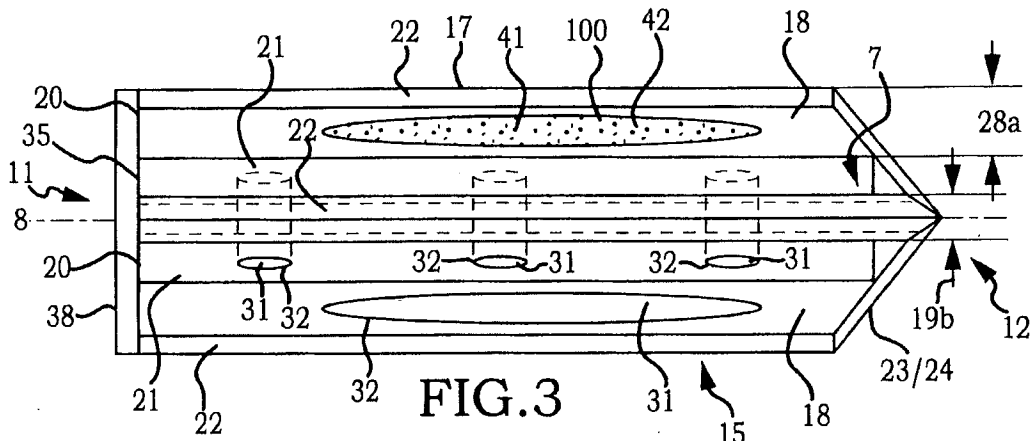

FIG. 1
CONVENTIONAL ART



2/29

FIG. 2



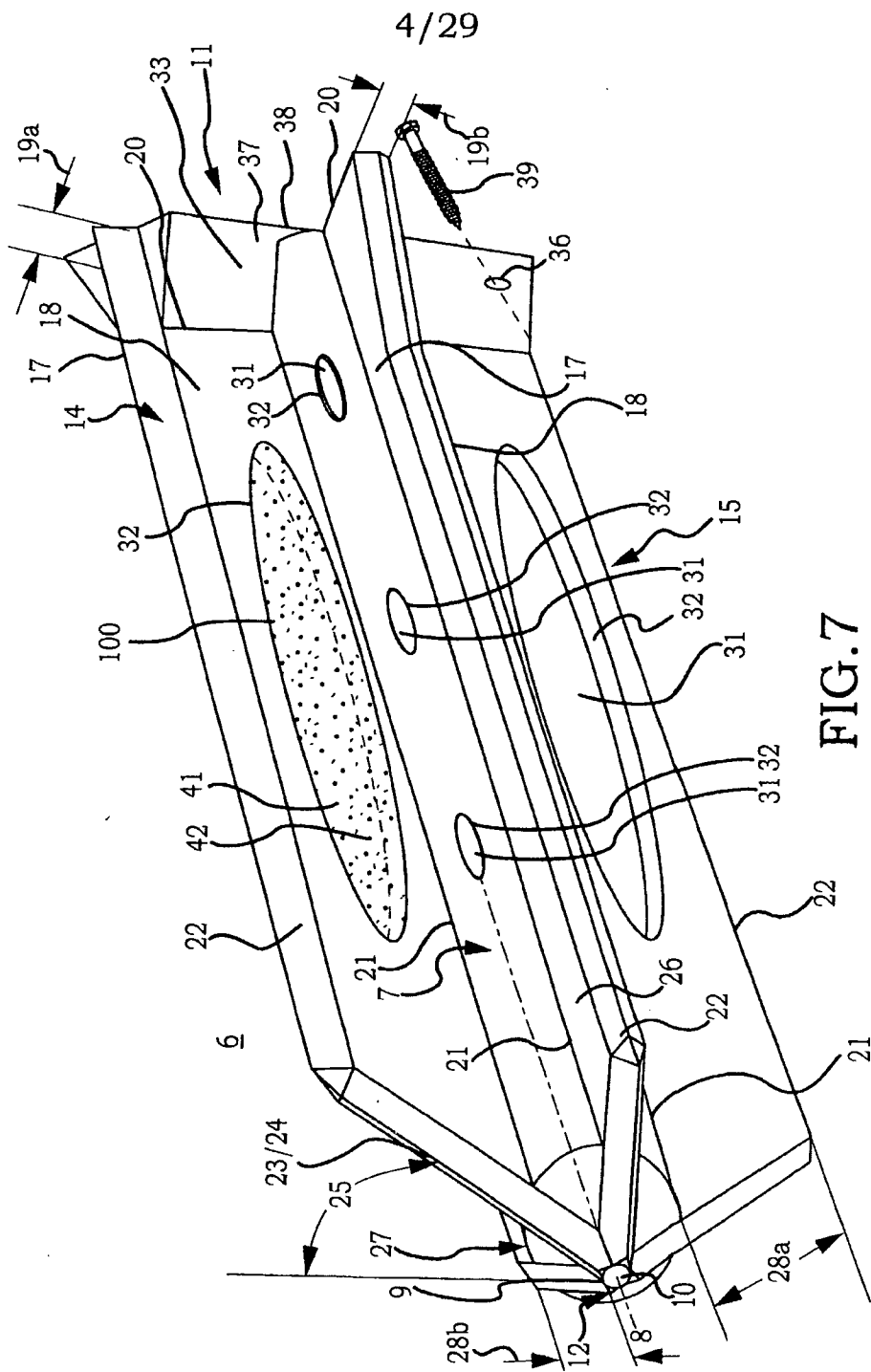
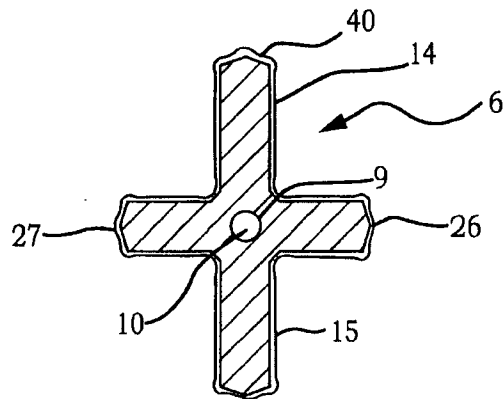
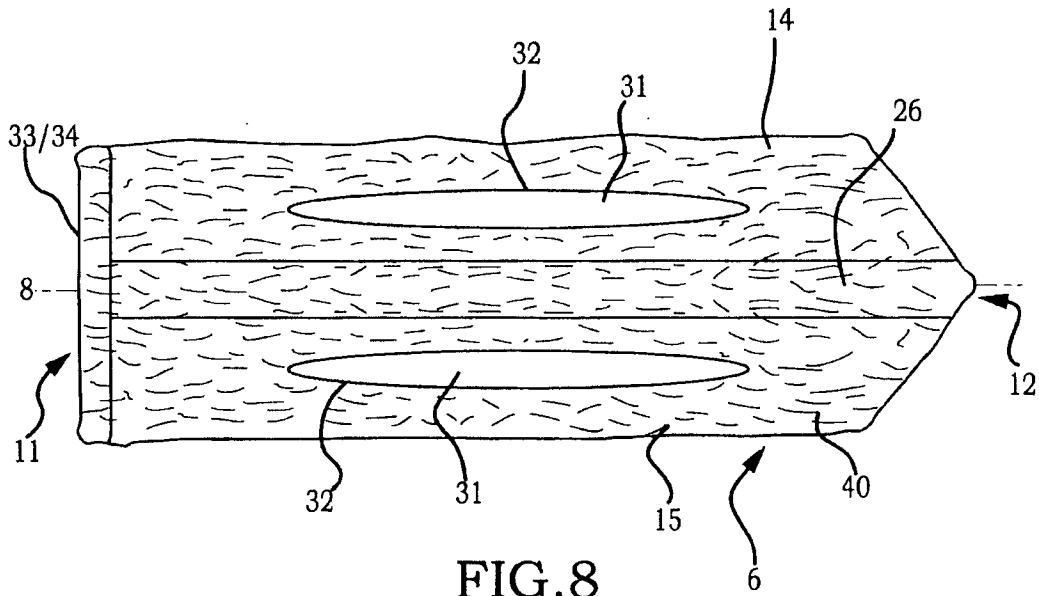
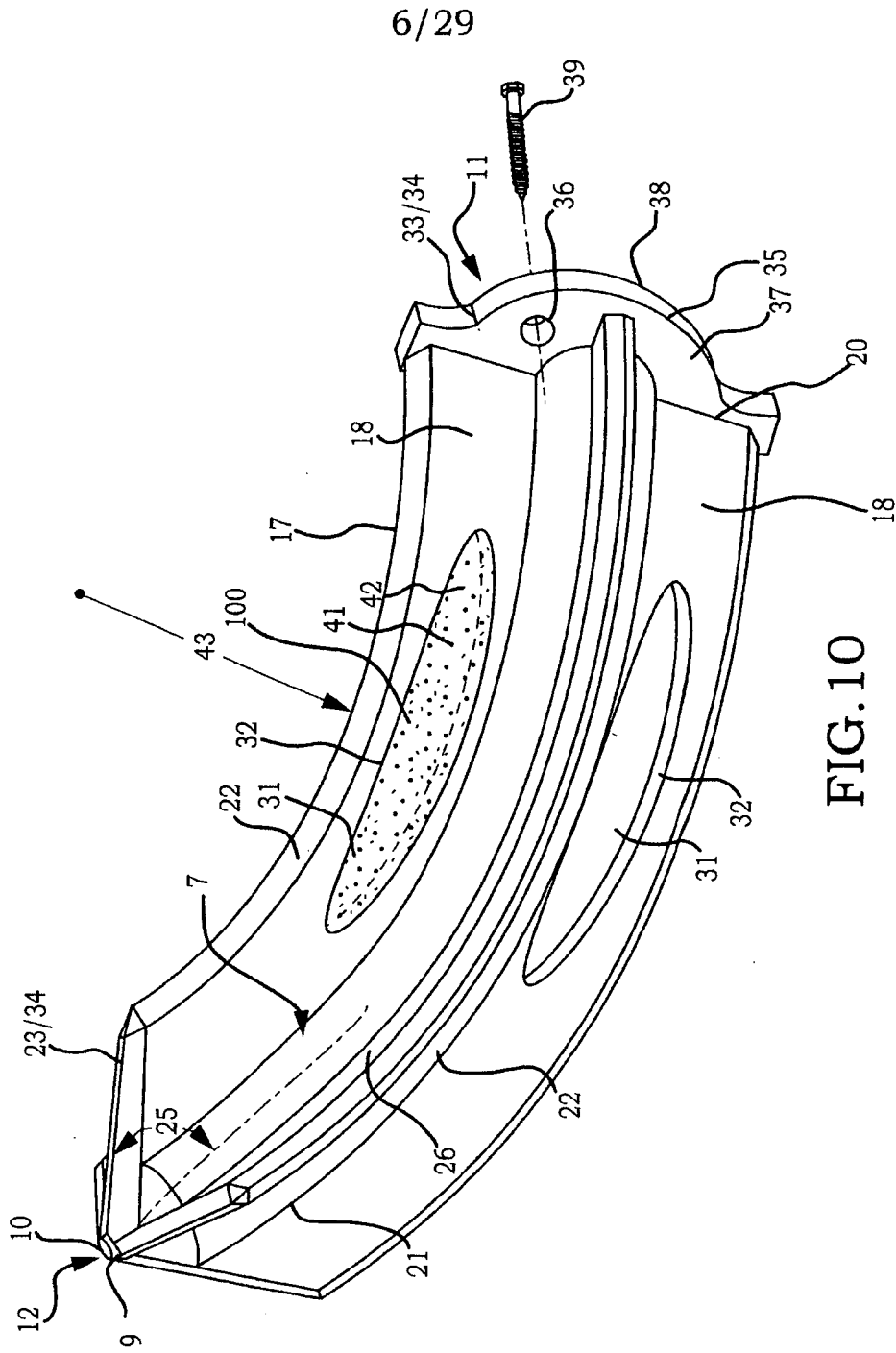

FIG. 7

5/29





6/29

FIG. 10

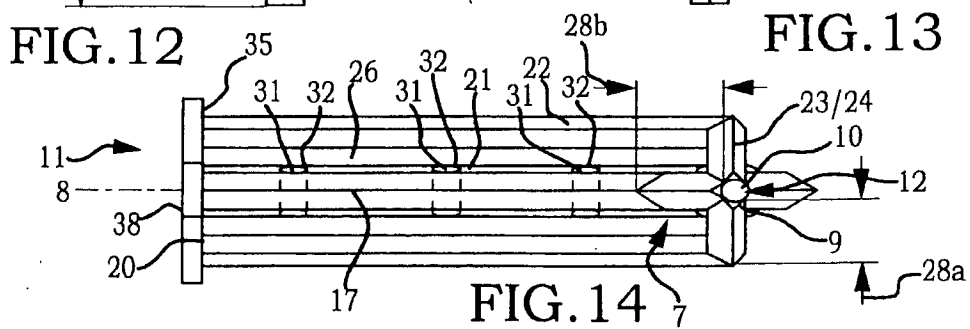
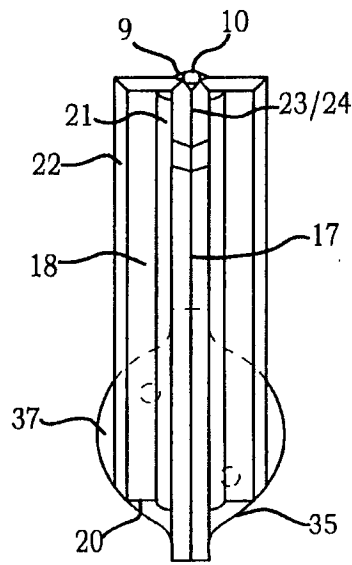
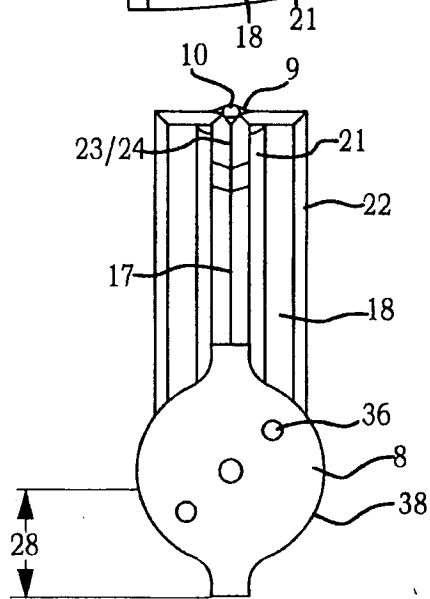
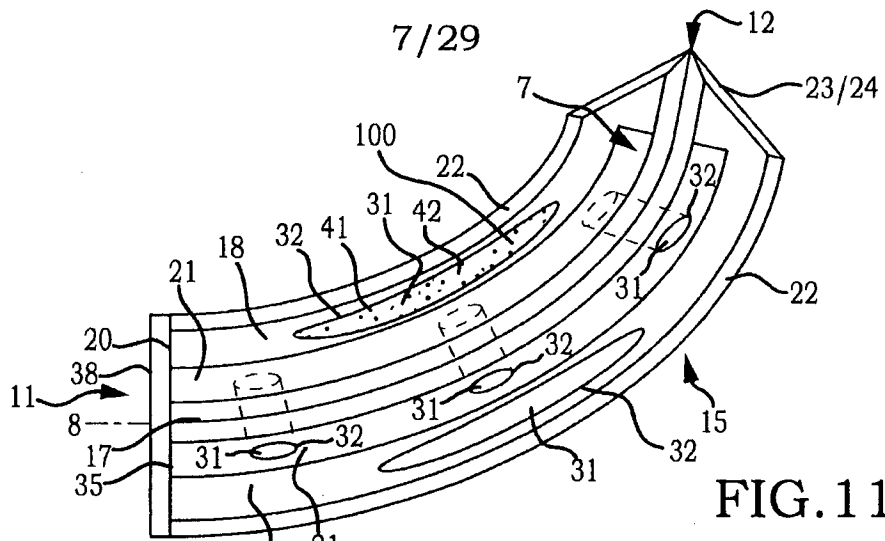

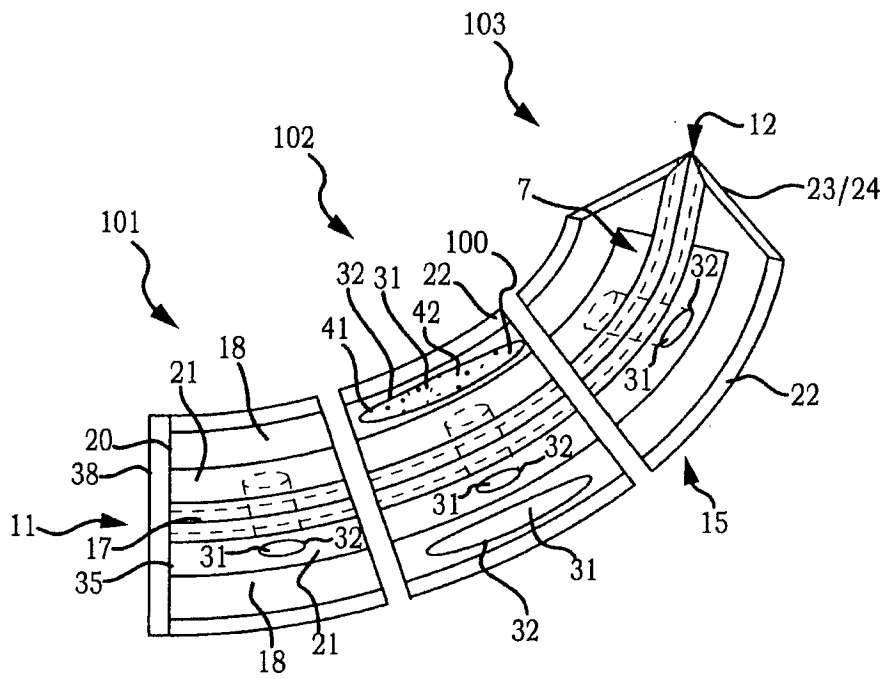

FIG. 15

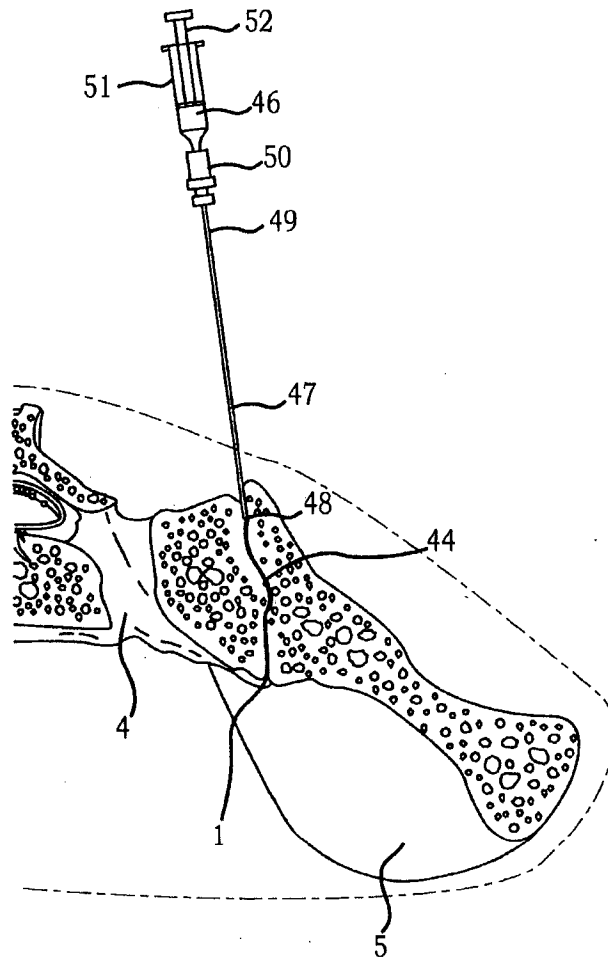

FIG. 16

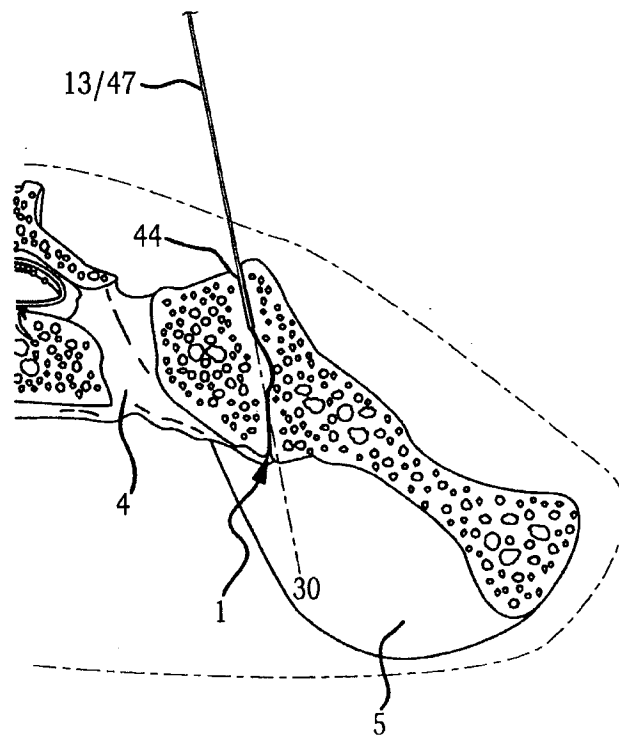

FIG. 17

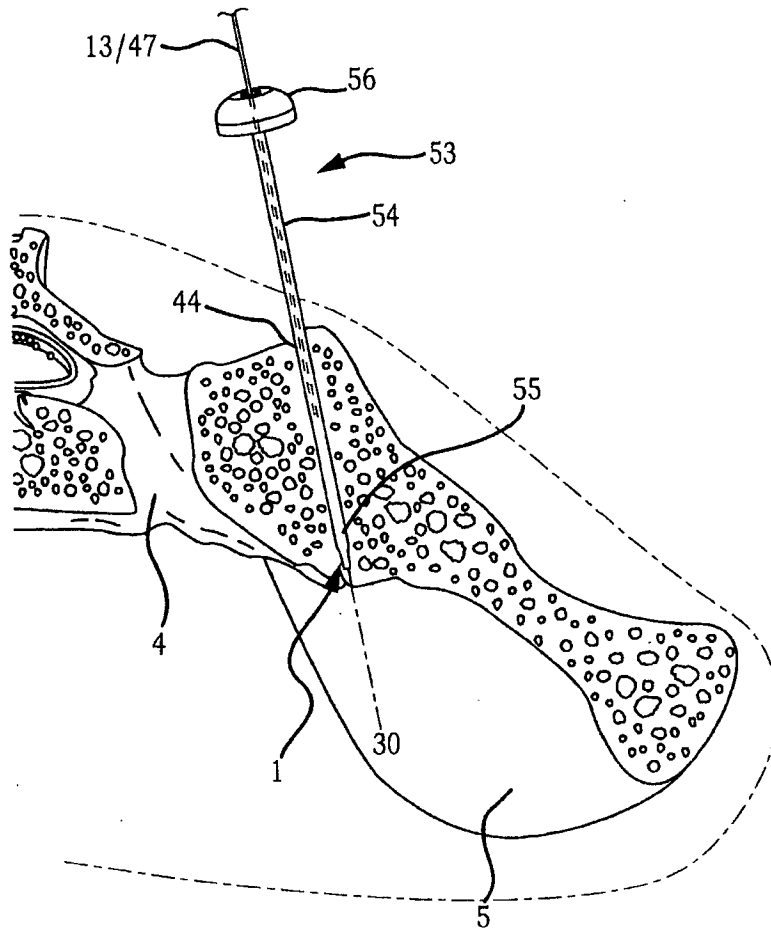

FIG. 18

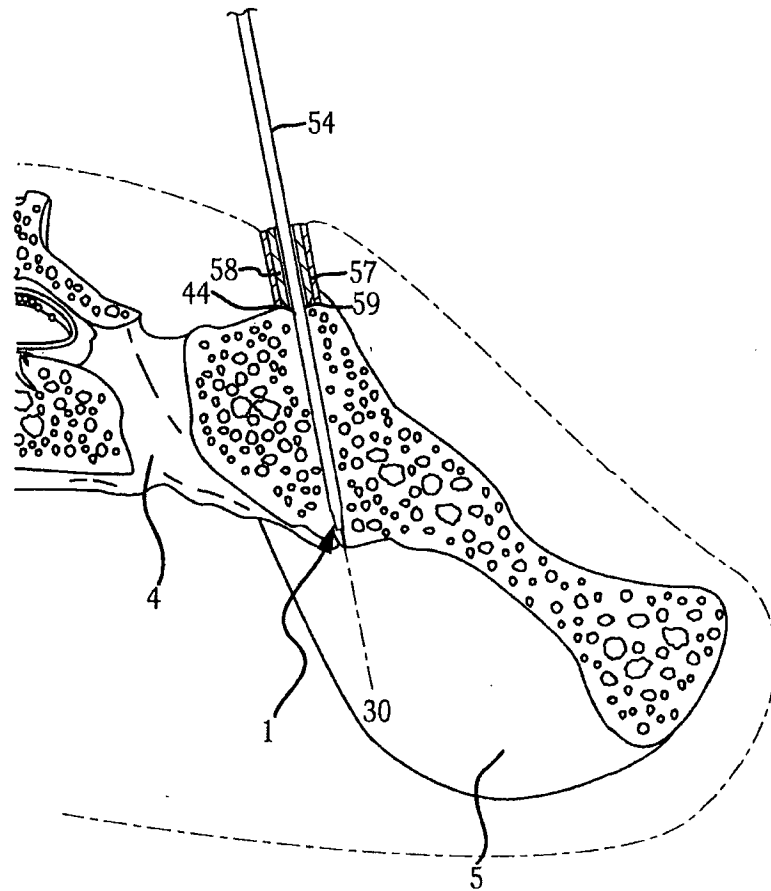

FIG. 19

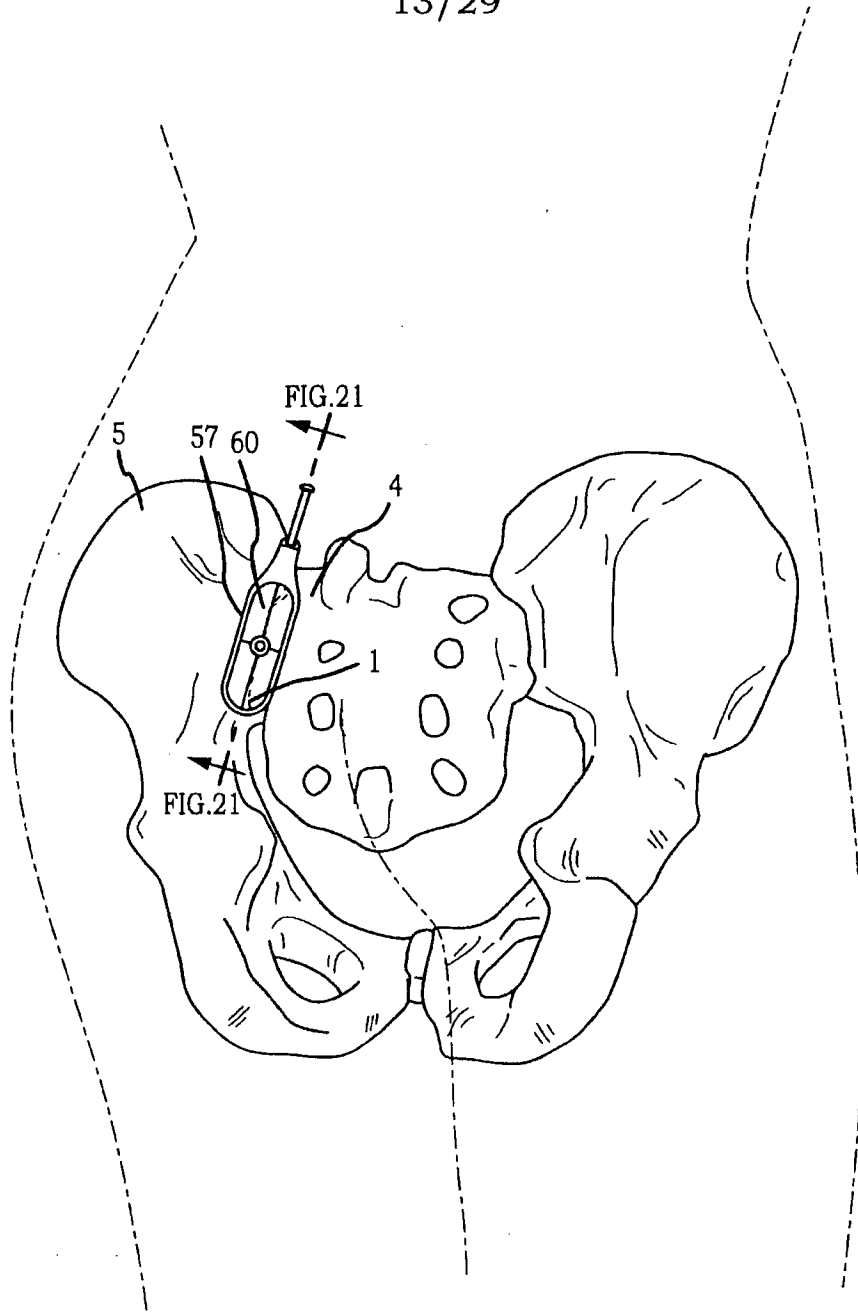

FIG. 20A

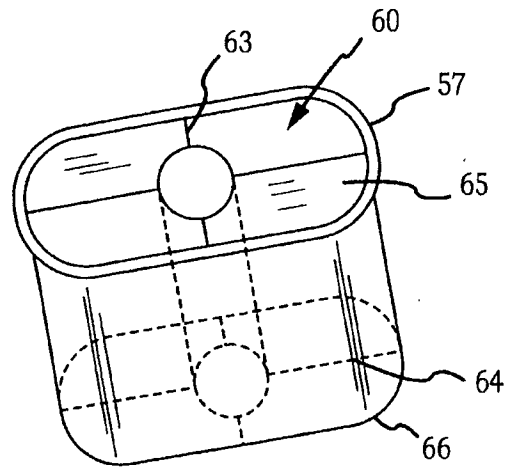

FIG. 20B

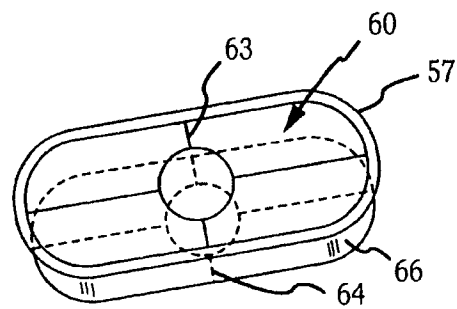

FIG. 20C

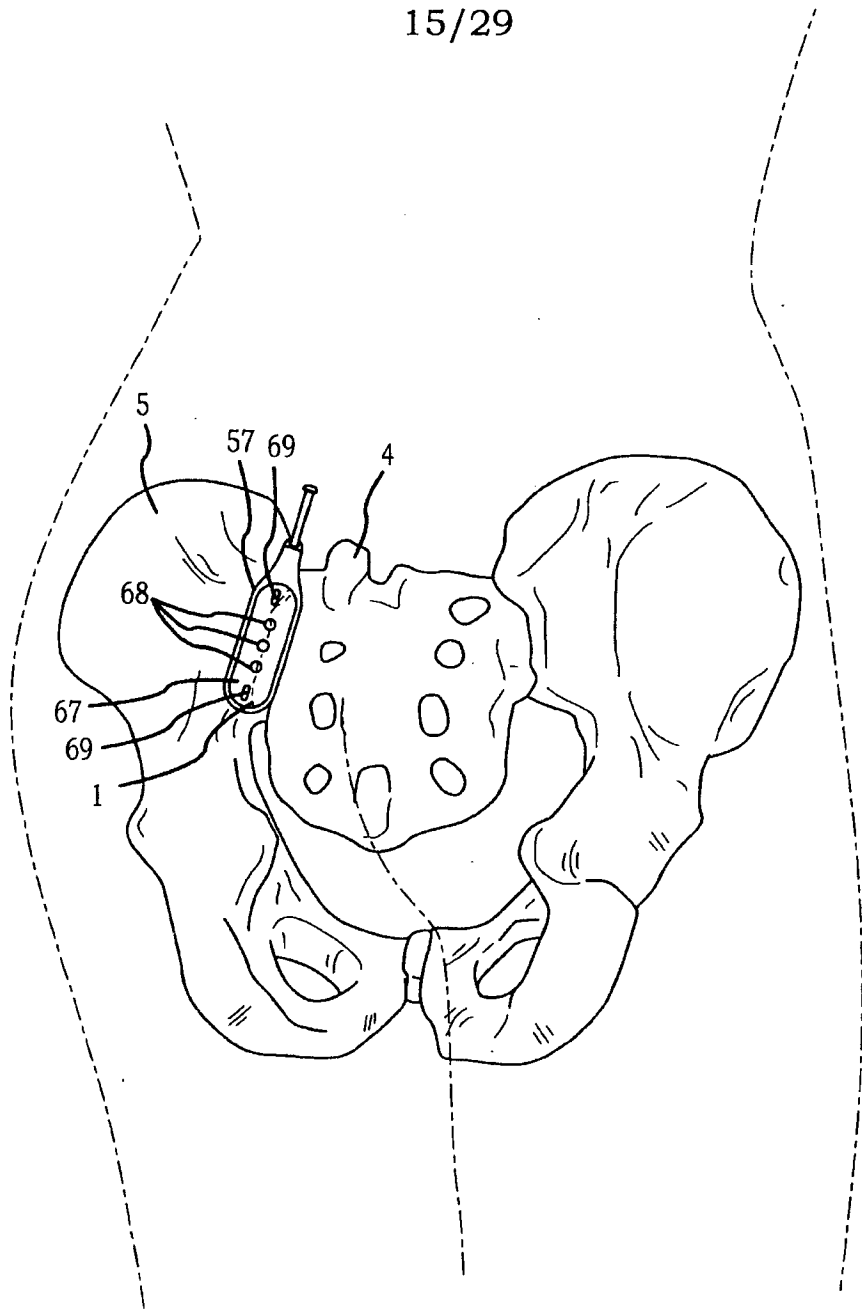

FIG.21A

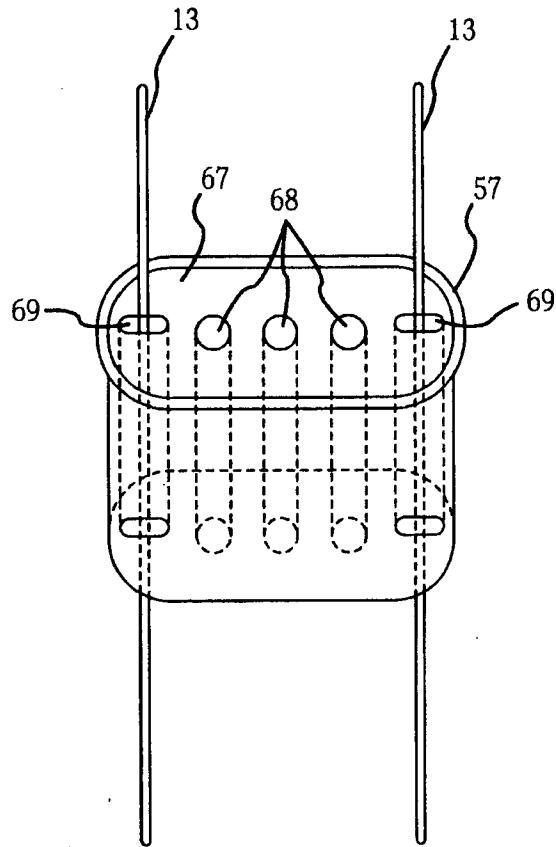

FIG.21B

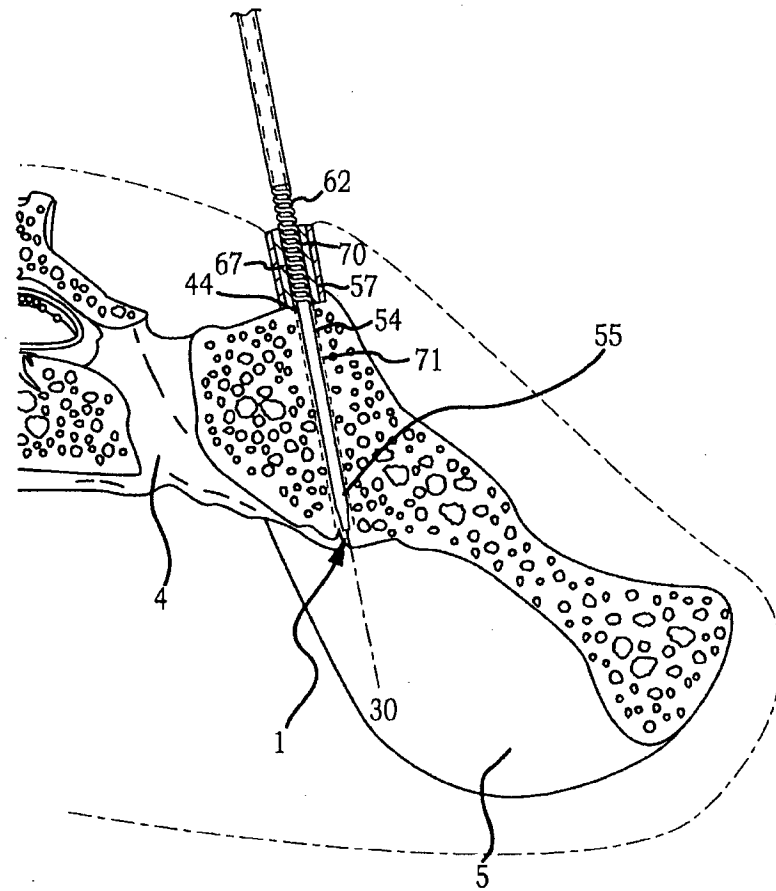

FIG.22

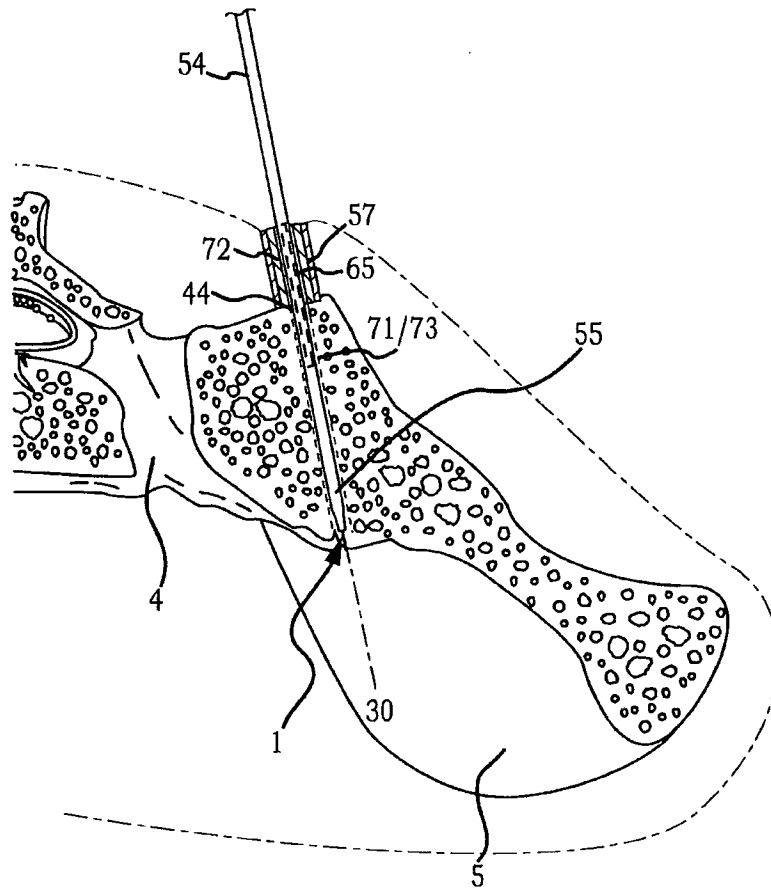

FIG.23

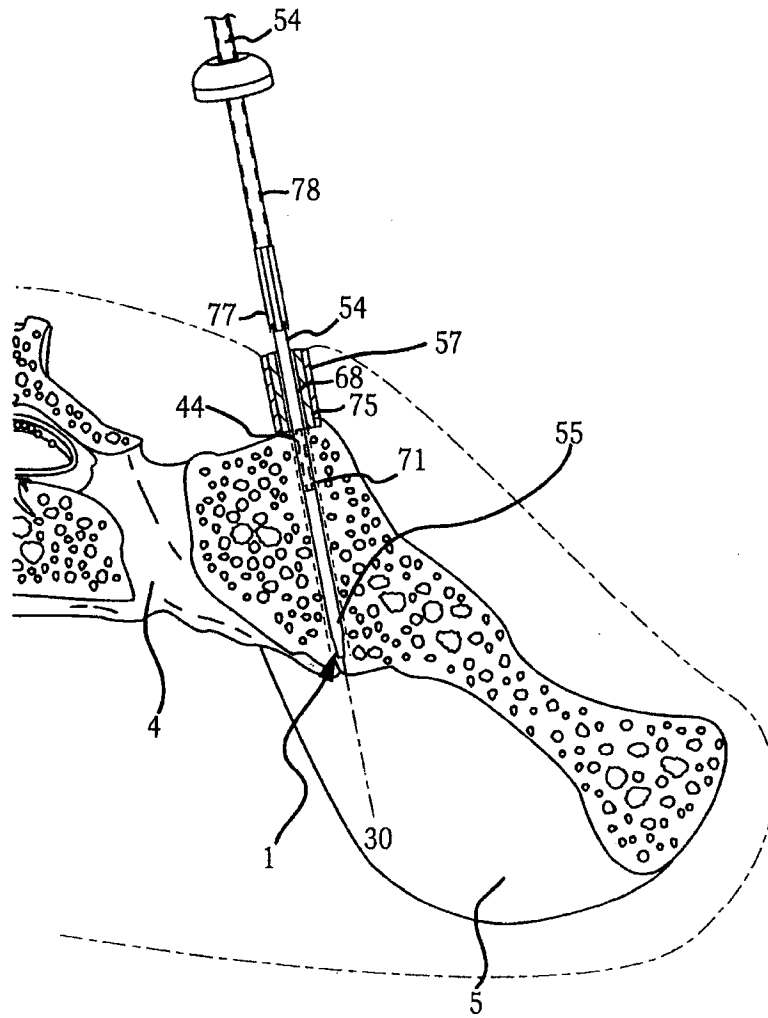

FIG. 24

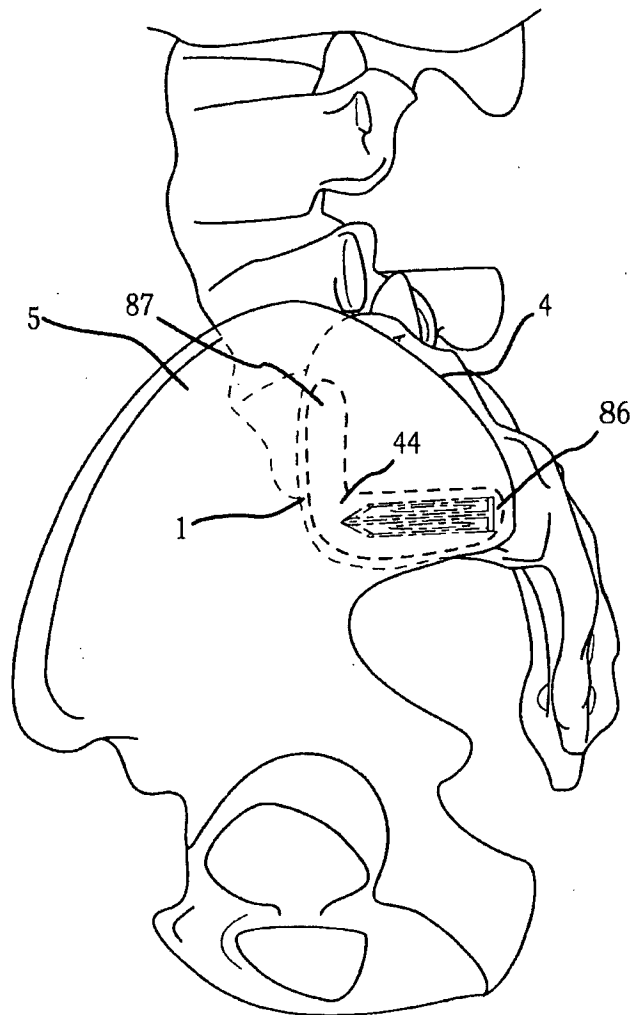

FIG.25

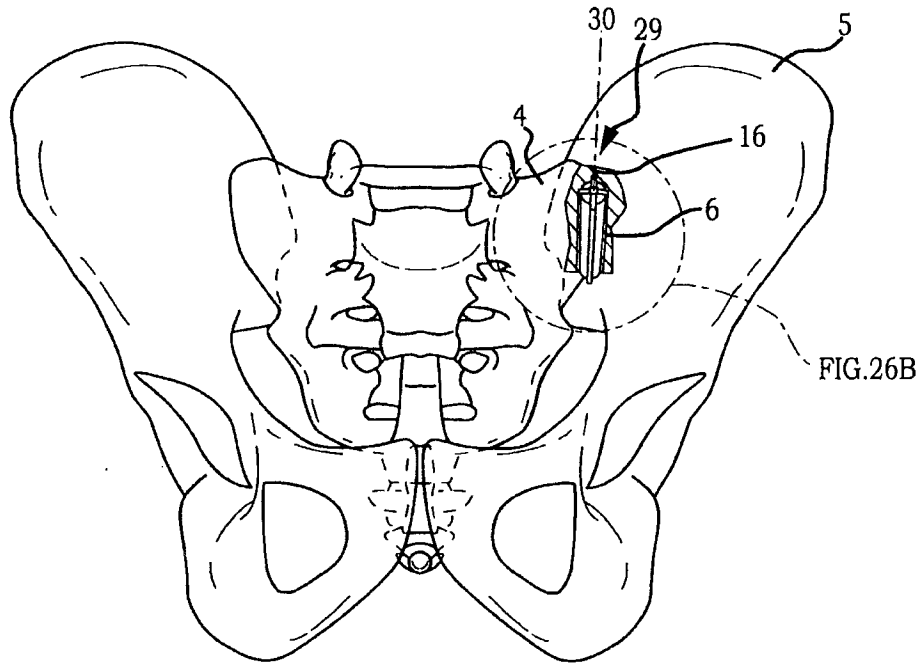

FIG. 26A

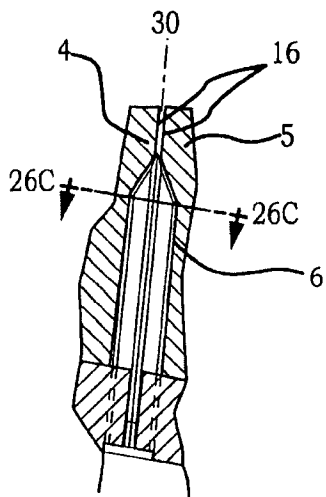

FIG. 26B

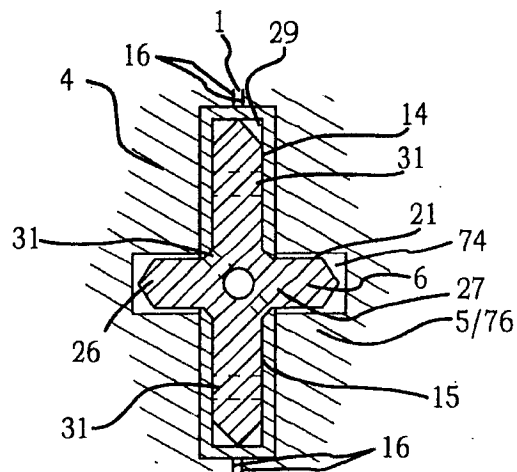

FIG. 26C

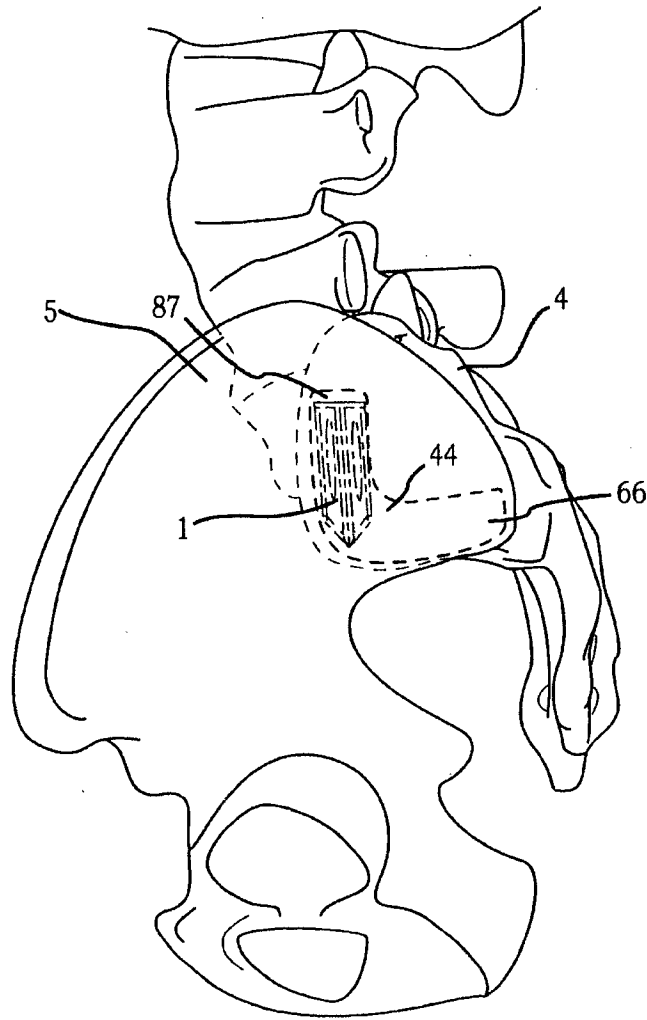

FIG.27

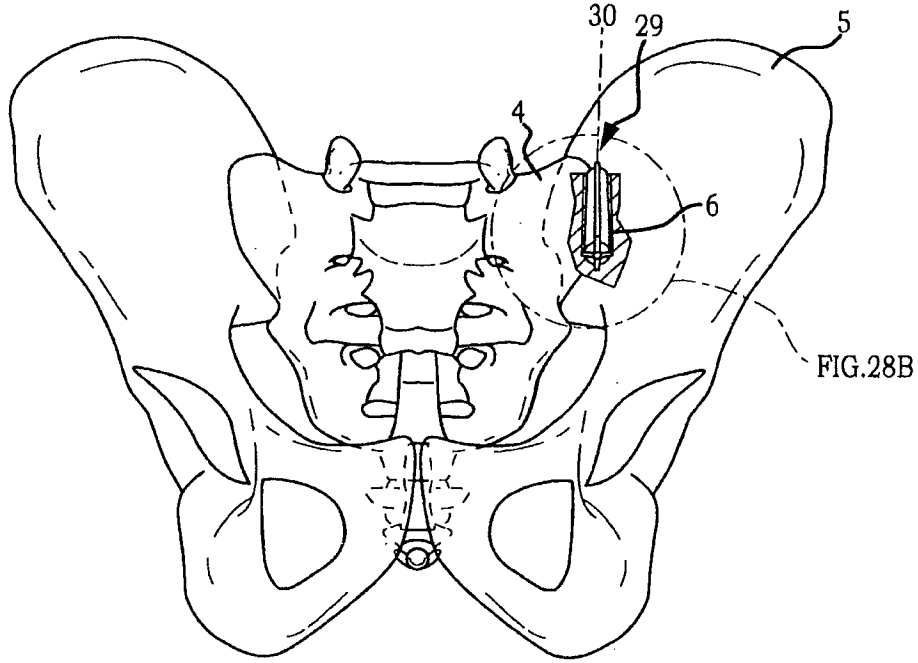

FIG. 28A

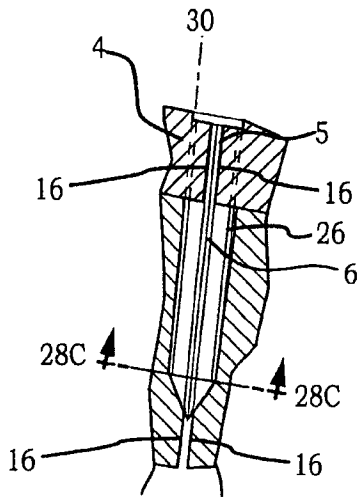

FIG. 28B

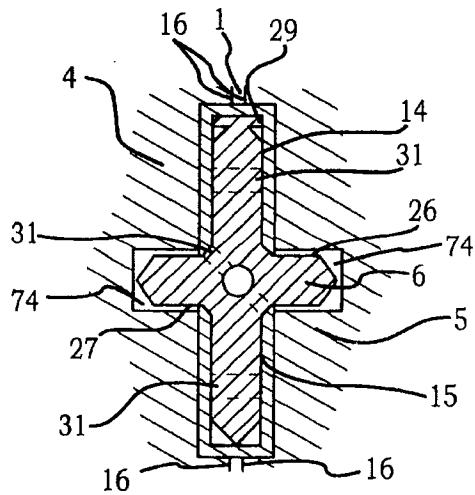

FIG. 28C

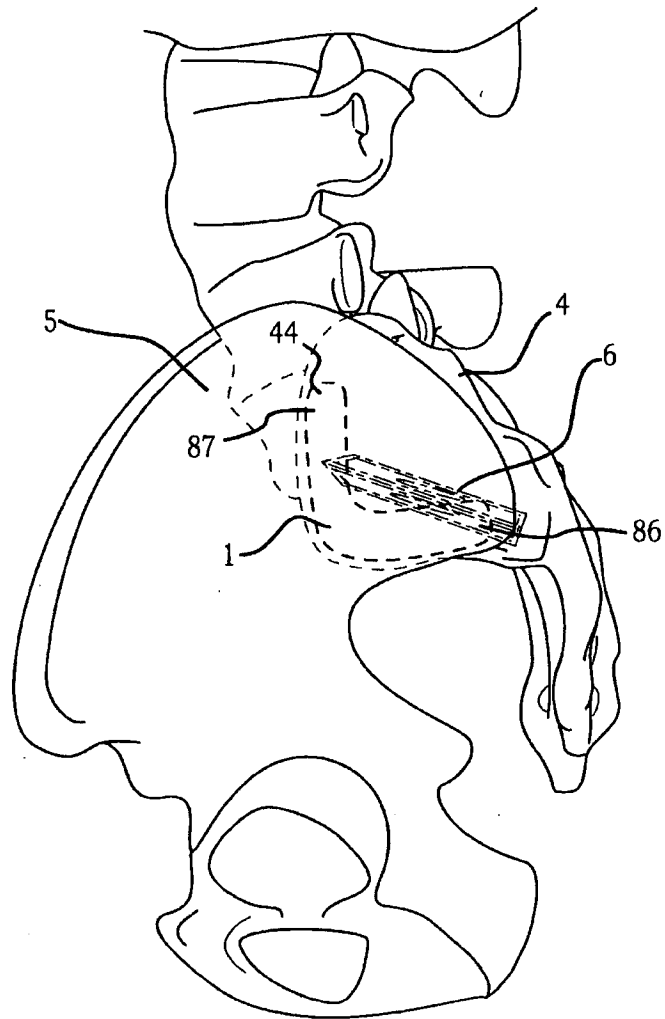

FIG.29

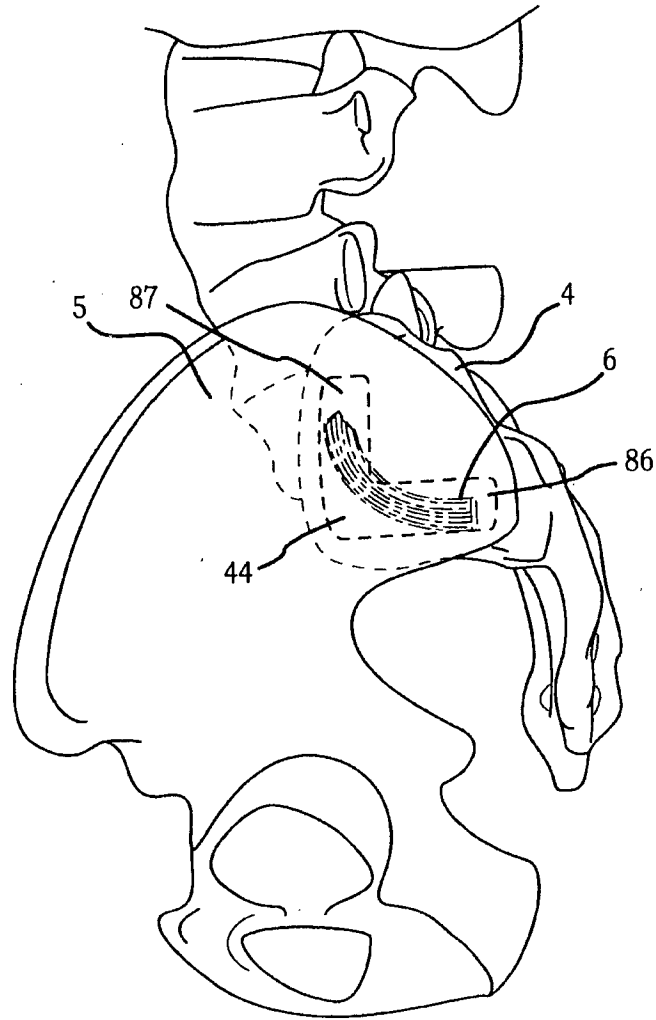

FIG.30

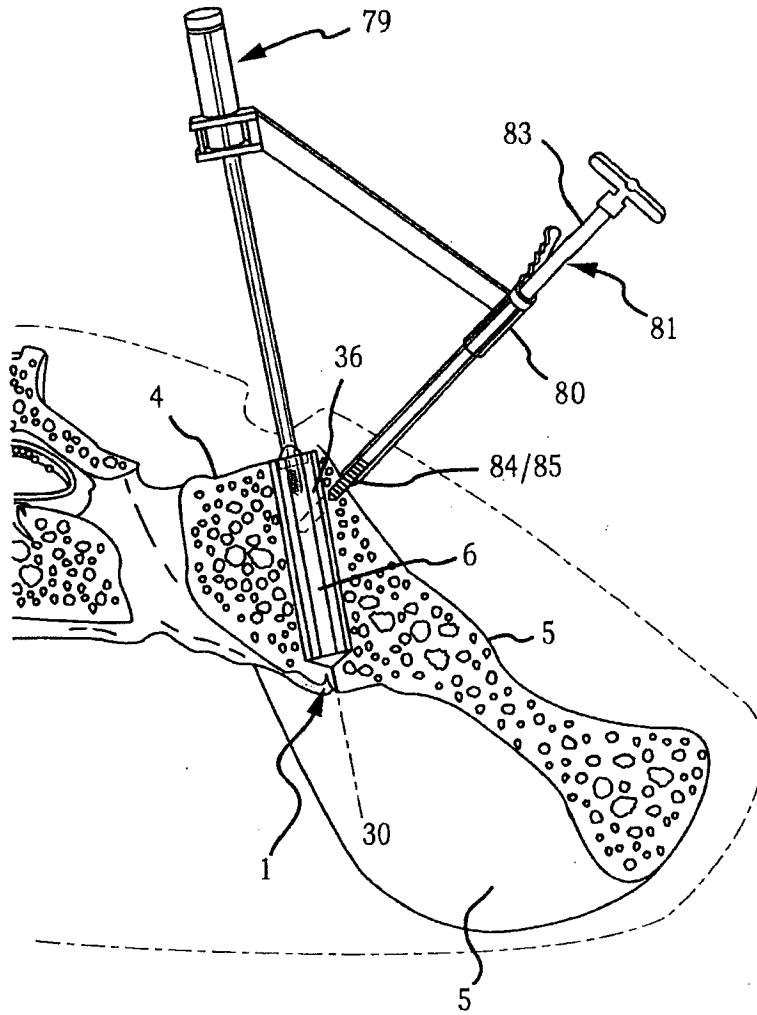

FIG.31

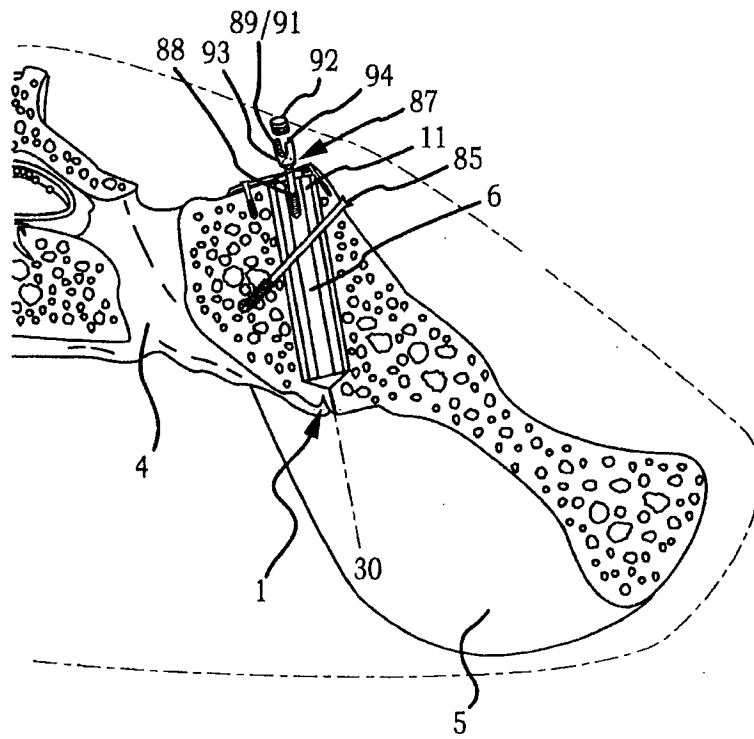

FIG.32

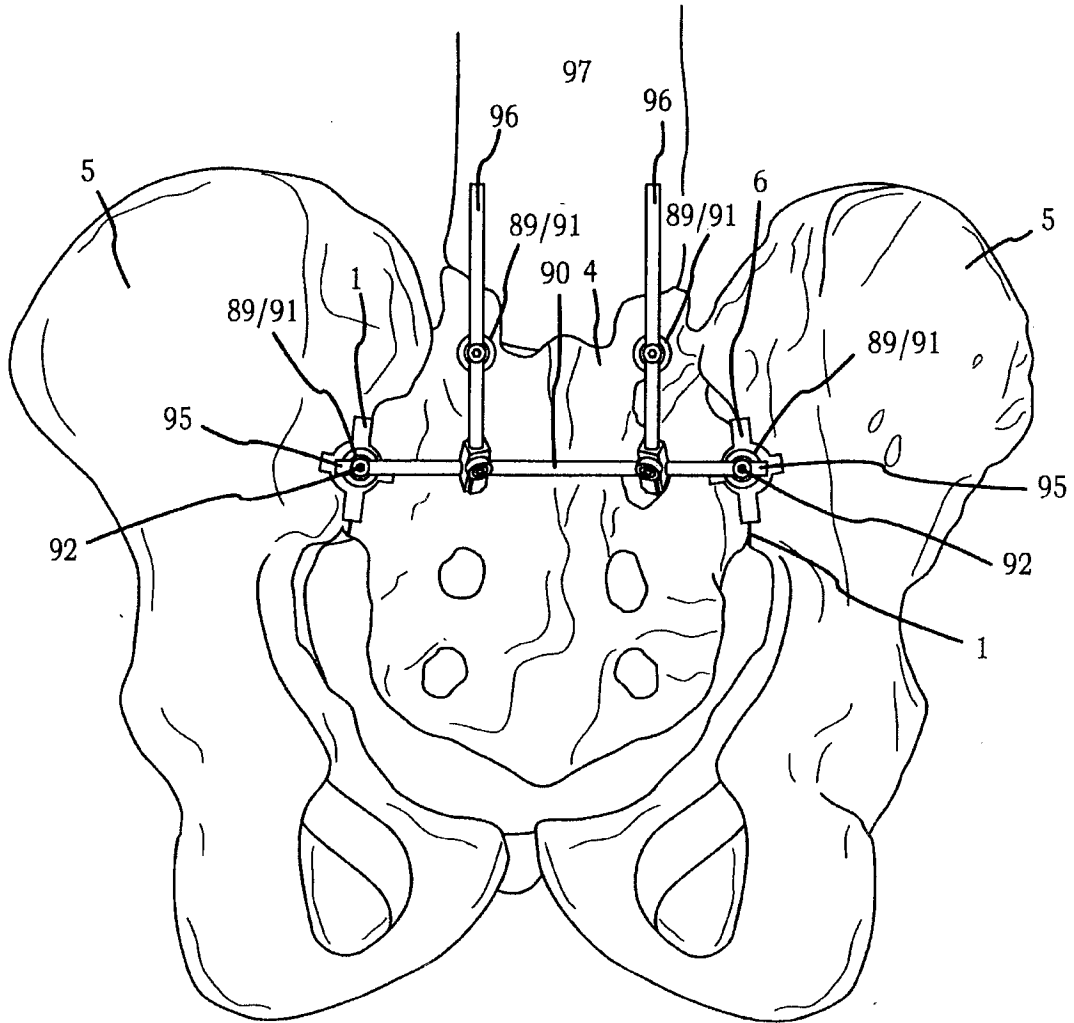

FIG.33

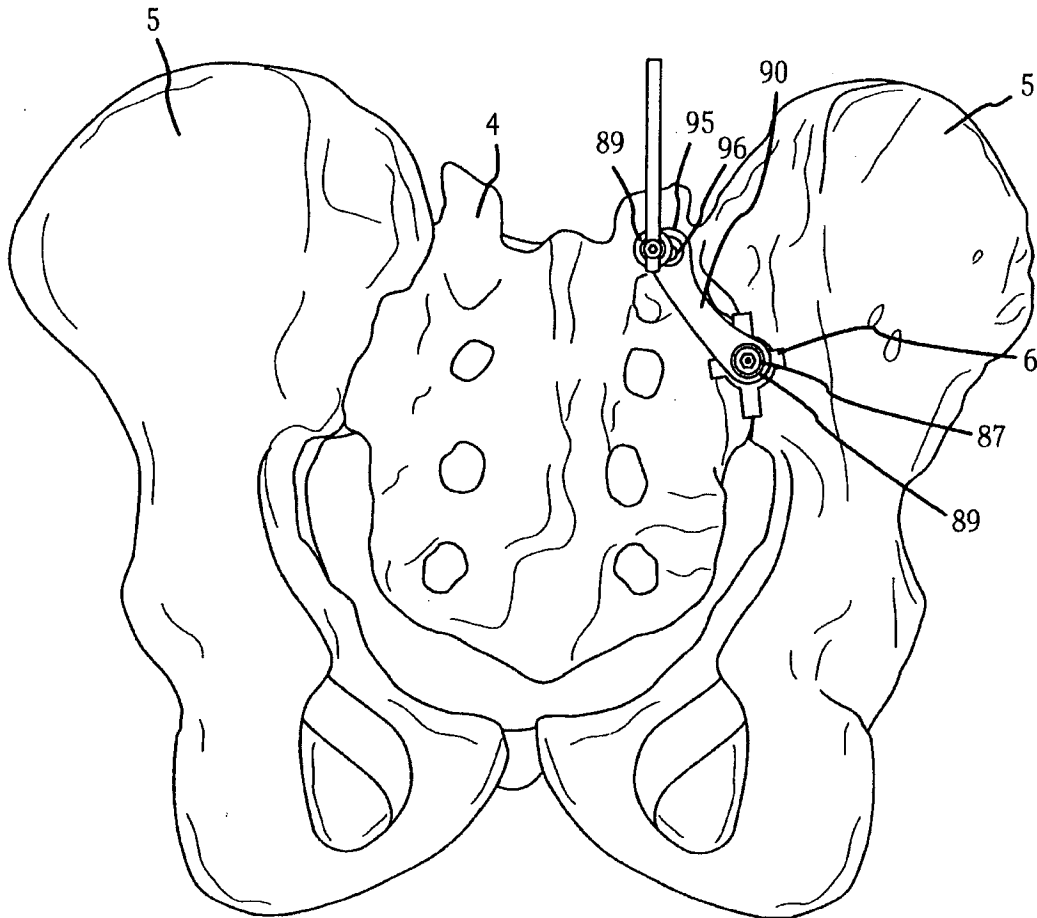

FIG.34