

(12) **United States Patent**  
**Donner et al.**

(10) **Patent No.:** **US 10,603,055 B2**  
(45) **Date of Patent:** **Mar. 31, 2020**

(54) **SYSTEMS FOR AND METHODS OF PREPARING AND FUSING A SACROILIAC JOINT**

(58) **Field of Classification Search**  
CPC ..... A61B 17/1757; A61F 2/30988  
See application file for complete search history.

(71) Applicant: **JCBD, LLC**, Fort Collins, CO (US)

(56) **References Cited**

(72) Inventors: **Edward Jeffrey Donner**, Fort Collins, CO (US); **Christopher Thomas Donner**, Fort Collins, CO (US); **Taylor Davis**, Atlanta, GA (US); **Brian VanHiel**, Atlanta, GA (US); **Hai Trieu**, Cordova, TN (US)

U.S. PATENT DOCUMENTS

3,426,364 A 2/1969 Lumb  
4,488,542 A 12/1984 Helland  
(Continued)

(73) Assignee: **JCBD, LLC**, Fort Collins, CO (US)

FOREIGN PATENT DOCUMENTS  
AU 1753200 8/2000  
CN 2265765 10/1997  
(Continued)

(\* ) Notice: Subject to any disclaimer, the term of this patent is extended or adjusted under 35 U.S.C. 154(b) by 4 days.

OTHER PUBLICATIONS

(21) Appl. No.: **16/133,605**

Arman et al. The Human Sacrum and Safe Approaches for Screw Placement. *Journal of Clinical Neuroscience* 2008 Elsevier Inc.;16(2009):1046-1049.

(22) Filed: **Sep. 17, 2018**

(Continued)

(65) **Prior Publication Data**

US 2019/0083271 A1 Mar. 21, 2019

*Primary Examiner* — Christian A Sevilla

(74) *Attorney, Agent, or Firm* — Polsinelli PC; Joshua J. Prancun; Samuel Wade Johnson

**Related U.S. Application Data**

(57) **ABSTRACT**

(60) Provisional application No. 62/559,386, filed on Sep. 15, 2017, provisional application No. 62/608,476, (Continued)

A system for performing a fusion procedure on a sacroiliac joint defined between a sacrum and an ilium. The system may include a working cannula including a proximal end, a distal end, a tubular body extending between the proximal and distal ends, a cannula passageway defined within the tubular body and having a cannula axis extending there through, a pair of prongs coupled to the tubular body and extending distally there from, an anchor arm engagement structure coupled to the tubular body, and a pin guide coupled to the tubular body and defining a pin passageway having a guidance axis there through that is generally parallel with the cannula axis.

(51) **Int. Cl.**  
**A61F 2/30** (2006.01)  
**A61F 2/46** (2006.01)  
(Continued)

(52) **U.S. Cl.**  
CPC ..... **A61B 17/1757** (2013.01); **A61B 17/1659** (2013.01); **A61B 17/1662** (2013.01);  
(Continued)

**31 Claims, 117 Drawing Sheets**

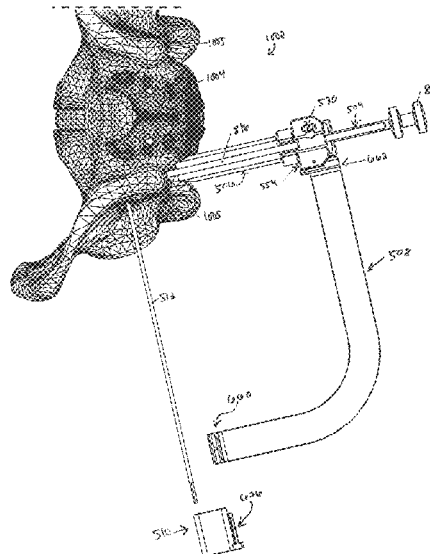

**Related U.S. Application Data**

filed on Dec. 20, 2017, provisional application No. 62/609,095, filed on Dec. 21, 2017, provisional application No. 62/632,635, filed on Feb. 20, 2018, provisional application No. 62/640,026, filed on Mar. 8, 2018.

(51) **Int. Cl.**

*A61B 17/16* (2006.01)  
*A61B 17/17* (2006.01)  
*A61B 17/70* (2006.01)  
*A61B 17/86* (2006.01)  
*A61B 17/02* (2006.01)  
*A61B 90/00* (2016.01)

(52) **U.S. Cl.**

CPC ..... *A61B 17/1671* (2013.01); *A61B 17/1739* (2013.01); *A61B 17/7055* (2013.01); *A61B 17/7076* (2013.01); *A61B 17/8625* (2013.01); *A61F 2/30749* (2013.01); *A61F 2/30988* (2013.01); *A61F 2/4603* (2013.01); *A61B 2017/0256* (2013.01); *A61B 2017/0275* (2013.01); *A61B 2090/062* (2016.02); *A61F 2002/30179* (2013.01); *A61F 2002/30271* (2013.01); *A61F 2002/30622* (2013.01); *A61F 2002/30769* (2013.01); *A61F 2002/30858* (2013.01); *A61F 2002/30995* (2013.01)

(56)

**References Cited**

U.S. PATENT DOCUMENTS

4,569,338 A 2/1986 Edwards  
 4,590,928 A 5/1986 Hunt et al.  
 4,622,959 A 11/1986 Marcus  
 4,714,469 A 12/1987 Kenna  
 4,773,402 A 9/1988 Asher et al.  
 4,794,918 A 1/1989 Wolter  
 4,805,602 A 2/1989 Puno  
 4,863,476 A 9/1989 Shepperd  
 4,881,535 A 11/1989 Sohngen  
 4,911,153 A 3/1990 Border  
 4,920,958 A 5/1990 Walt et al.  
 4,950,270 A 8/1990 Bowman et al.  
 5,026,373 A 6/1991 Ray et al.  
 5,052,375 A 10/1991 Stark et al.  
 5,108,397 A 4/1992 White  
 5,112,337 A 5/1992 Paulos et al.  
 5,176,681 A 1/1993 Lawes et al.  
 5,192,327 A 3/1993 Brantigan  
 5,242,444 A 9/1993 MacMillan  
 5,282,861 A 2/1994 Kaplan  
 5,334,192 A 8/1994 Behrens  
 5,334,205 A 8/1994 Cain  
 5,336,225 A 8/1994 Zang  
 5,368,546 A 11/1994 Stark et al.  
 5,368,593 A 11/1994 Stark  
 5,437,674 A 8/1995 Worcel et al.  
 5,443,509 A 8/1995 Boucher et al.  
 5,456,267 A 10/1995 Stark  
 5,480,402 A 1/1996 Kim  
 5,484,389 A 1/1996 Stark et al.  
 5,591,165 A 1/1997 Jackson  
 5,591,235 A 1/1997 Kuslich  
 5,593,407 A 1/1997 Reis  
 5,607,424 A 3/1997 Tropiano  
 5,609,635 A 3/1997 Michelson  
 5,609,636 A 3/1997 Kohrs et al.  
 5,626,434 A 5/1997 Cook  
 5,658,337 A 8/1997 Kohrs et al.  
 5,662,652 A 9/1997 Schafer  
 5,669,909 A 9/1997 Zdeblick et al.  
 5,683,391 A 11/1997 Boyd  
 5,688,284 A 11/1997 Chervitz et al.

5,743,914 A 4/1998 Skiba  
 5,772,594 A 6/1998 Barrick  
 5,823,975 A 10/1998 Stark et al.  
 5,888,224 A 3/1999 Beckers et al.  
 5,891,150 A 4/1999 Chan  
 5,919,193 A 7/1999 Slavitt  
 5,928,239 A 7/1999 Mirza  
 5,929,782 A 7/1999 Stark et al.  
 5,993,463 A 11/1999 Truwit  
 6,053,916 A 4/2000 Moore  
 6,056,749 A 5/2000 Kuslich  
 6,063,442 A 5/2000 Cohen et al.  
 6,175,758 B1 1/2001 Kambin  
 6,184,797 B1 2/2001 Stark et al.  
 6,236,891 B1 5/2001 Ingle et al.  
 6,241,771 B1 6/2001 Gresser et al.  
 6,290,724 B1 9/2001 Marino  
 6,296,595 B1 10/2001 Stark et al.  
 6,302,885 B1 10/2001 Essiger  
 6,322,562 B1 11/2001 Wolter  
 6,325,827 B1 12/2001 Lin  
 6,371,123 B1 4/2002 Stark et al.  
 6,413,278 B1 7/2002 Marchosky  
 6,432,107 B1 8/2002 Ferree  
 6,432,140 B1 8/2002 Lin  
 6,515,593 B1 2/2003 Stark et al.  
 6,520,990 B1 2/2003 Ray  
 6,540,707 B1 4/2003 Stark et al.  
 6,547,795 B2 4/2003 Schneiderman  
 6,547,823 B2 4/2003 Scarborough et al.  
 6,558,423 B1 5/2003 Michelson  
 6,565,605 B2 5/2003 Goble et al.  
 6,572,622 B1 6/2003 Schäfer et al.  
 6,579,318 B2 6/2003 Varga et al.  
 6,607,487 B2 8/2003 Chang et al.  
 6,635,059 B2 10/2003 Randall et al.  
 6,641,614 B1 11/2003 Wagner  
 6,660,224 B2 12/2003 Lefebvre et al.  
 6,663,669 B1 12/2003 Reiley  
 6,669,698 B1 12/2003 Tromanhauser et al.  
 6,682,563 B2 1/2004 Scharf  
 6,682,567 B1 1/2004 Schroeder  
 6,716,245 B2 4/2004 Pasquet et al.  
 6,723,099 B1 4/2004 Goshert  
 6,743,256 B2 6/2004 Mason  
 6,746,451 B2 6/2004 Middleton et al.  
 6,824,564 B2 11/2004 Crozet  
 6,827,670 B1 12/2004 Stark et al.  
 6,835,208 B2 12/2004 Marchosky  
 6,855,166 B2 2/2005 Kohrs  
 6,855,167 B2 2/2005 Shimp et al.  
 6,860,902 B2 3/2005 Reiley  
 6,872,187 B1 3/2005 Stark et al.  
 6,875,236 B2 4/2005 Reiley  
 6,902,567 B2 6/2005 Del Medico  
 6,908,465 B2 6/2005 von Hoffmann et al.  
 6,945,448 B2 9/2005 Medlin et al.  
 6,972,019 B2 12/2005 Michelson  
 6,974,461 B1 12/2005 Wolter  
 7,011,660 B2 3/2006 Sherman et al.  
 7,087,056 B2 8/2006 Vaughan  
 7,087,058 B2 8/2006 Cragg  
 7,108,828 B2 9/2006 Lefebvre et al.  
 7,144,399 B2 12/2006 Hayes et al.  
 7,163,560 B2 1/2007 Mason  
 7,192,447 B2 3/2007 Rhoda  
 7,201,775 B2 4/2007 Gorensek et al.  
 7,208,222 B2 4/2007 Rolfe et al.  
 7,217,291 B2 5/2007 Zucherman et al.  
 7,229,448 B2 6/2007 Goble et al.  
 7,235,101 B2 6/2007 Berry et al.  
 7,235,105 B2 6/2007 Jackson  
 7,247,157 B2 7/2007 Prager et al.  
 7,255,712 B1 8/2007 Steinberg  
 7,303,563 B2 12/2007 Poyner et al.  
 7,331,995 B2 2/2008 Eisermann et al.  
 7,396,360 B2 7/2008 Lieberman  
 7,410,501 B2 8/2008 Michelson  
 7,416,537 B1 8/2008 Stark et al.

(56)

## References Cited

## U.S. PATENT DOCUMENTS

7,458,991	B2	12/2008	Wang et al.	8,623,062	B2	1/2014	Kondrashov
7,465,317	B2	12/2008	Malberg et al.	8,740,912	B2	6/2014	Stark
7,520,898	B2	4/2009	Re et al.	8,778,026	B2	7/2014	Mauldin
7,537,616	B1	5/2009	Branch et al.	8,808,305	B2	8/2014	Kleiner
7,575,600	B2	8/2009	Zucherman et al.	8,808,336	B2	8/2014	Duggal et al.
7,621,939	B2	11/2009	Zucherman et al.	8,808,377	B2	8/2014	Donner
7,635,447	B2	12/2009	Hamman et al.	8,808,380	B2	8/2014	Fox et al.
7,637,954	B2	12/2009	Michelson	8,808,389	B2	8/2014	Reiley
7,641,697	B2	1/2010	Reiley	8,821,546	B2	9/2014	Vaughan
7,648,509	B2	1/2010	Stark	8,840,651	B2	9/2014	Reiley
7,666,209	B2	2/2010	Zucherman et al.	8,882,818	B1	11/2014	Vestgaarden
7,670,383	B1	3/2010	Brown et al.	8,894,708	B2	11/2014	Thalgott et al.
7,704,279	B2	4/2010	Moskowitz et al.	8,945,224	B2	2/2015	Trieu
7,713,290	B2	5/2010	Vaughan	8,979,928	B2	3/2015	Donner
7,740,795	B2	6/2010	Wang et al.	8,992,579	B1	3/2015	Gustine et al.
7,771,441	B2	8/2010	Cerundolo	9,017,407	B2	4/2015	Donner
7,789,895	B2	9/2010	Heinz	9,039,765	B2	5/2015	Trieu
7,794,465	B2	9/2010	Marik et al.	9,039,768	B2	5/2015	Voellmicke
7,799,081	B2	9/2010	McKinley	9,044,321	B2	6/2015	Mauldin
7,819,869	B2	10/2010	Godara et al.	9,060,815	B1	6/2015	Gustine et al.
7,824,404	B2	11/2010	Godara et al.	9,119,732	B2	9/2015	Schifano
7,837,732	B2	11/2010	Zucherman et al.	9,149,286	B1	10/2015	Greenhalgh
7,837,734	B2	11/2010	Zucherman et al.	9,186,155	B2	11/2015	Katzman et al.
7,846,162	B2	12/2010	Nelson et al.	9,254,130	B2	2/2016	Hollis
7,850,690	B2	12/2010	Frigg et al.	9,283,084	B1	3/2016	O'Hara
7,850,719	B2	12/2010	Gournay et al.	9,333,090	B2	5/2016	Donner et al.
7,850,732	B2	12/2010	Heinz	9,381,045	B2	7/2016	Donner et al.
7,909,871	B2	3/2011	Abdou	9,421,109	B2	8/2016	Donner et al.
7,918,891	B1	4/2011	Curran et al.	9,452,065	B1	9/2016	Lawson
7,922,765	B2	4/2011	Reiley	9,474,538	B2	10/2016	Foley
7,935,116	B2	5/2011	Michelson	9,480,511	B2	11/2016	Butters
7,942,903	B2	5/2011	Moskowitz et al.	9,486,264	B2	11/2016	Reiley
7,963,970	B2	6/2011	Marino et al.	9,554,909	B2	1/2017	Donner et al.
7,972,363	B2	7/2011	Moskowitz et al.	9,700,356	B2	7/2017	Donner et al.
7,972,382	B2	7/2011	Foley et al.	9,717,539	B2	8/2017	Donner et al.
7,985,255	B2	7/2011	Bray et al.	9,757,154	B2	9/2017	Donner et al.
8,034,114	B2	10/2011	Reiley	9,788,961	B2	10/2017	Donner et al.
8,034,115	B2	10/2011	Reiley	9,795,396	B2	10/2017	Donner et al.
8,048,164	B2	11/2011	Reiley	9,801,546	B2	10/2017	Donner et al.
8,070,782	B2	12/2011	McKay	9,820,783	B2	11/2017	Donner et al.
8,075,561	B2	12/2011	Wolter	9,826,986	B2	11/2017	Donner et al.
8,083,796	B1	12/2011	Raiszadeh et al.	9,833,265	B2	12/2017	Donner et al.
8,088,163	B1	1/2012	Kleiner	9,833,320	B2	12/2017	Donner et al.
8,128,666	B2	3/2012	Falahee	9,931,212	B1	4/2018	Donner et al.
8,162,981	B2	4/2012	Vestgaarden	9,936,983	B2	4/2018	Mesiwala
8,187,332	B2	5/2012	McLuen	9,949,835	B2	4/2018	Donner
8,202,305	B2	6/2012	Reiley	9,949,843	B2	4/2018	Reiley
8,221,428	B2	7/2012	Trieu	10,034,676	B2	7/2018	Donner
8,231,661	B2	7/2012	Carls et al.	10,058,430	B2	8/2018	Donner et al.
8,308,779	B2	11/2012	Reiley	10,064,727	B2	9/2018	Donner et al.
8,308,794	B2	11/2012	Martinson et al.	10,064,728	B2	9/2018	Donner et al.
8,317,862	B2	11/2012	Troger et al.	10,130,477	B2	11/2018	Donner et al.
8,343,189	B2	1/2013	Assell et al.	10,136,995	B2	11/2018	Donner et al.
8,343,219	B2	1/2013	Allain et al.	10,159,573	B2	12/2018	Donner
8,348,950	B2	1/2013	Assell et al.	10,179,014	B1	1/2019	Menmuir
8,388,667	B2	3/2013	Reiley	10,245,087	B2	4/2019	Donner et al.
8,414,648	B2	4/2013	Reiley	10,265,176	B2	4/2019	Donner et al.
8,425,570	B2	4/2013	Reiley	10,292,720	B2	5/2019	Donner
8,425,603	B2	4/2013	Reichen et al.	10,314,710	B2	6/2019	Donner et al.
8,439,925	B2	5/2013	Marino et al.	10,321,945	B2	6/2019	Schifano
8,444,693	B2	5/2013	Reiley	10,335,197	B2	7/2019	Donner et al.
8,454,618	B2	6/2013	Stark	10,383,664	B2	8/2019	Donner et al.
8,470,004	B2	6/2013	Reiley	10,433,880	B2	10/2019	Donner et al.
8,470,037	B2	6/2013	Re et al.	10,441,318	B2	10/2019	Donner et al.
8,480,755	B2	7/2013	Reiley	10,492,688	B2	12/2019	Donner et al.
8,491,572	B2	7/2013	Martinson et al.	10,492,802	B2	12/2019	Donner et al.
8,491,653	B2	7/2013	Zucherman et al.	2001/0000532	A1*	4/2001	Michelson ..... A61B 17/025 606/80
8,496,712	B2	7/2013	Reiley	2001/0005796	A1	6/2001	Zdeblick et al.
8,501,690	B2	8/2013	Stark	2001/0018616	A1	8/2001	Schwab
8,518,120	B2	8/2013	Glerum	2001/0020143	A1	9/2001	Stark et al.
8,551,171	B2	10/2013	Johnson et al.	2002/0029784	A1	3/2002	Stark et al.
8,562,651	B2	10/2013	Metcalf et al.	2002/0032484	A1	3/2002	Hyde, Jr.
8,579,912	B2	11/2013	Isaza et al.	2002/0068941	A1	6/2002	Hanson
8,585,744	B2	11/2013	Duggal et al.	2002/0068977	A1	6/2002	Jackson
D697,209	S	1/2014	Walthall, Jr. et al.	2002/0082701	A1	6/2002	Zdeblick et al.
				2002/0087161	A1	7/2002	Randall et al.
				2002/0103487	A1	8/2002	Errico
				2002/0147461	A1	10/2002	Aldrich et al.

(56)		References Cited					
		U.S. PATENT DOCUMENTS					
2002/0147496	A1	10/2002	Belef et al.	2008/0228276	A1	9/2008	Mathews et al.
2002/0183846	A1	12/2002	Kuslich et al.	2008/0262621	A1	10/2008	Gorek
2003/0114931	A1	6/2003	Lee et al.	2008/0281425	A1	11/2008	Thalgott et al.
2003/0124486	A1	7/2003	McDevitt	2008/0288081	A1	11/2008	Scrafton et al.
2003/0181981	A1	9/2003	Lemaire	2008/0300685	A1	12/2008	Carls et al.
2003/0208202	A1	11/2003	Falahee	2009/0018660	A1	1/2009	Roush
2004/0073216	A1	4/2004	Lieberman	2009/0024174	A1	1/2009	Stark
2004/0097932	A1*	5/2004	Ray, III	2009/0024217	A1	1/2009	Levy
			..... A61B 17/1757	2009/0043394	A1	2/2009	Zdeblick et al.
			606/86 A	2009/0062914	A1	3/2009	Marino
				2009/0076553	A1	3/2009	Wolter
				2009/0088849	A1	4/2009	Armstrong et al.
				2009/0099659	A1	4/2009	Oh
2004/0127988	A1	7/2004	Goble et al.	2009/0105833	A1	4/2009	Hovda et al.
2004/0162558	A1	8/2004	Hegde et al.	2009/0105834	A1	4/2009	Hovda et al.
2004/0162616	A1	8/2004	Simonton	2009/0131986	A1	5/2009	Lee et al.
2004/0186482	A1	9/2004	Kolb et al.	2009/0132035	A1	5/2009	Roth et al.
2004/0193271	A1	9/2004	Fraser	2009/0149957	A1	6/2009	Burd et al.
2004/0199256	A1	10/2004	Wang	2009/0192621	A1	7/2009	Winslow et al.
2004/0220668	A1	11/2004	Eisermann et al.	2009/0204215	A1	8/2009	McClintock
2004/0228901	A1	11/2004	Trieu	2009/0216276	A1	8/2009	Pasquet
2004/0249675	A1	12/2004	Stark et al.	2009/0248163	A1	10/2009	King et al.
2004/0260286	A1	12/2004	Ferree	2009/0259261	A1	10/2009	Reiley
2005/0043660	A1	2/2005	Stark et al.	2009/0259316	A1	10/2009	Ginn et al.
2005/0101887	A1	5/2005	Stark et al.	2009/0281579	A1	11/2009	Weaver
2005/0113652	A1	5/2005	Stark et al.	2009/0287254	A1	11/2009	Nayet et al.
2005/0131539	A1	6/2005	Kohrs	2009/0306671	A1	12/2009	McCormack et al.
2005/0149192	A1	7/2005	Zucherman et al.	2010/0057204	A1	3/2010	Kadaba
2005/0154391	A1	7/2005	Doherty et al.	2010/0094290	A1	4/2010	Vaidya
2005/0203515	A1	9/2005	Doherty et al.	2010/0100135	A1	4/2010	Phan
2005/0216088	A1	9/2005	McKinley et al.	2010/0106200	A1	4/2010	Stark
2005/0240264	A1	10/2005	Tokish, Jr. et al.	2010/0121160	A1	5/2010	Stark et al.
2005/0245925	A1	11/2005	Iki et al.	2010/0137910	A1	6/2010	Cawley et al.
2005/0261775	A1	11/2005	Baum	2010/0137919	A1	6/2010	Wolter
2005/0267482	A1	12/2005	Hyde, Jr.	2010/0145397	A1	6/2010	Overes
2005/0273099	A1	12/2005	Baccelli et al.	2010/0152785	A1	6/2010	Forton et al.
2006/0036251	A1	2/2006	Reiley	2010/0168798	A1	7/2010	Clineff
2006/0054171	A1	3/2006	Dall	2010/0168861	A1	7/2010	Yundt
2006/0058876	A1	3/2006	McKinley	2010/0179552	A1	7/2010	Wolter
2006/0069438	A1	3/2006	Zucherman et al.	2010/0185292	A1	7/2010	Hochschuler
2006/0085068	A1	4/2006	Barry	2010/0191088	A1	7/2010	Anderson
2006/0089716	A1	4/2006	Felix	2010/0191100	A1	7/2010	Anderson
2006/0095134	A1	5/2006	Trieu et al.	2010/0204795	A1	8/2010	Greenhalgh
2006/0129244	A1	6/2006	Ensign	2010/0204796	A1	8/2010	Bae
2006/0147332	A1	7/2006	Jones et al.	2010/0211176	A1	8/2010	Greenhalgh
2006/0161154	A1	7/2006	McAfee	2010/0217086	A1	8/2010	Deshmukh
2006/0167547	A1	7/2006	Suddaby	2010/0268228	A1	10/2010	Petersen
2006/0229729	A1	10/2006	Gordon	2010/0286779	A1	11/2010	Thibodeau
2007/0027543	A1	2/2007	Gimble et al.	2010/0286785	A1	11/2010	Grayson
2007/0055374	A1	3/2007	Copf, Jr. et al.	2010/0292796	A1	11/2010	Greenhalgh
2007/0155588	A1	7/2007	Stark et al.	2010/0292800	A1	11/2010	Zubok
2007/0156241	A1	7/2007	Reiley et al.	2010/0305702	A1	12/2010	Michelson
2007/0162134	A1	7/2007	Marnay et al.	2010/0305704	A1	12/2010	Messerli
2007/0179610	A1	8/2007	Biedermann	2010/0324607	A1	12/2010	Davis
2007/0179621	A1	8/2007	McClellan, III et al.	2010/0331981	A1	12/2010	Mohammed
2007/0198093	A1	8/2007	Brodke et al.	2011/0034957	A1	2/2011	Biedermann
2007/0225714	A1	9/2007	Gradl	2011/0046737	A1	2/2011	Teisen
2007/0239164	A1	10/2007	Prager et al.	2011/0071568	A1	3/2011	Ginn et al.
2007/0239278	A1	10/2007	Heinz	2011/0071635	A1	3/2011	Zhang et al.
2007/0265621	A1	11/2007	Matthis et al.	2011/0087294	A1	4/2011	Reiley
2007/0270879	A1	11/2007	Isaza et al.	2011/0093074	A1	4/2011	Glerum
2007/0270968	A1	11/2007	Baynham	2011/0098816	A1	4/2011	Jacob et al.
2007/0276501	A1	11/2007	Betz et al.	2011/0098817	A1	4/2011	Eckhardt et al.
2007/0293949	A1	12/2007	Salerni et al.	2011/0118796	A1	5/2011	Reiley
2007/0299445	A1	12/2007	Shaddock	2011/0160866	A1	6/2011	Laurence
2007/0299525	A1	12/2007	Binotto	2011/0172774	A1	7/2011	Varela
2008/0015704	A1	1/2008	Gradl	2011/0184518	A1	7/2011	Trieu
2008/0021454	A1	1/2008	Chao et al.	2011/0184519	A1	7/2011	Trieu
2008/0021455	A1	1/2008	Chao et al.	2011/0184520	A1	7/2011	Trieu
2008/0021456	A1	1/2008	Gupta et al.	2011/0185306	A1	7/2011	Aravamudan
2008/0021461	A1	1/2008	Barker et al.	2011/0213221	A1	9/2011	Roche
2008/0039843	A1	2/2008	Abdou	2011/0230968	A1	9/2011	Perisic
2008/0045968	A1	2/2008	Yu et al.	2011/0238181	A1	9/2011	Trieu
2008/0065215	A1	3/2008	Reiley	2011/0264233	A1	10/2011	Song
2008/0133016	A1	6/2008	Heinz	2011/0295272	A1	12/2011	Assell et al.
2008/0140082	A1	6/2008	Erdem et al.	2012/0010714	A1	1/2012	Moskowitz et al.
2008/0140207	A1	6/2008	Olmos	2012/0022535	A1	1/2012	Mayer et al.
2008/0154314	A1	6/2008	McDevitt	2012/0022595	A1	1/2012	Pham et al.
2008/0183293	A1	7/2008	Parry et al.	2012/0029641	A1	2/2012	Curran et al.

(56)

## References Cited

## U.S. PATENT DOCUMENTS

2012/0032808	A1	2/2012	Cherubini
2012/0035729	A1	2/2012	Glerum
2012/0065548	A1	3/2012	Morgan
2012/0083883	A1	4/2012	Ginn
2012/0116454	A1	5/2012	Eddidin et al.
2012/0116806	A1	5/2012	Stark et al.
2012/0150300	A1	6/2012	Nihalani
2012/0185049	A1	7/2012	Varela
2012/0209388	A1	8/2012	Curran et al.
2012/0253406	A1	10/2012	Bae
2012/0259370	A1	10/2012	Vaidya
2012/0271200	A1	10/2012	Martinson et al.
2012/0271424	A1	10/2012	Crawford
2012/0316565	A1	12/2012	Stark
2012/0323285	A1	12/2012	Assell et al.
2013/0006361	A1	1/2013	Glerum
2013/0018427	A1	1/2013	Pham et al.
2013/0023994	A1	1/2013	Glerum
2013/0030456	A1	1/2013	Assell et al.
2013/0035724	A1	2/2013	Fitzpatrick
2013/0035727	A1	2/2013	Datta
2013/0053854	A1	2/2013	Schoenefeld et al.
2013/0053902	A1	2/2013	Trudeau
2013/0053964	A1	2/2013	Talwar
2013/0060337	A1	3/2013	Petersheim et al.
2013/0066426	A1	3/2013	Martinson et al.
2013/0085535	A1	4/2013	Greenhalgh et al.
2013/0090735	A1	4/2013	Mermuys et al.
2013/0116790	A1	5/2013	Seifert
2013/0123850	A1	5/2013	Schoenefeld et al.
2013/0123923	A1	5/2013	Pavlov et al.
2013/0144343	A1	6/2013	Arnett et al.
2013/0144393	A1	6/2013	Mutchler
2013/0158669	A1	6/2013	Sungarian
2013/0173004	A1	7/2013	Greenhalgh
2013/0197590	A1	8/2013	Assell et al.
2013/0218215	A1	8/2013	Ginn et al.
2013/0226181	A1	8/2013	Assell et al.
2013/0231746	A1	9/2013	Ginn et al.
2013/0238093	A1	9/2013	Mauldin
2013/0245703	A1	9/2013	Warren et al.
2013/0245763	A1	9/2013	Mauldin
2013/0253650	A1	9/2013	Ashley
2013/0282012	A1	10/2013	Stark
2013/0295202	A1	11/2013	Stark
2013/0296953	A1	11/2013	Mauldin
2013/0297035	A1	11/2013	Reiley
2014/0012330	A1	1/2014	Johnson, II et al.
2014/0012340	A1	1/2014	Beck et al.
2014/0031934	A1	1/2014	Trieu
2014/0039628	A1	2/2014	DeLurio et al.
2014/0046380	A1	2/2014	Asfora
2014/0074175	A1	3/2014	Ehler et al.
2014/0100662	A1	4/2014	Patterson et al.
2014/0114415	A1	4/2014	Tyber
2014/0135850	A1	5/2014	Parent et al.
2014/0135927	A1	5/2014	Pavlov et al.
2014/0156007	A1	6/2014	Pabst et al.
2014/0207240	A1	7/2014	Stoffman
2014/0249581	A1	9/2014	Stachniak
2014/0257294	A1	9/2014	Gedet et al.
2014/0257399	A1	9/2014	Rezach
2014/0257408	A1	9/2014	Trieu et al.
2014/0257411	A1	9/2014	Rezach
2014/0257486	A1	9/2014	Alheidt
2014/0277463	A1	9/2014	Yerby
2014/0277478	A1	9/2014	Moore
2014/0277504	A1	9/2014	Forton et al.
2014/0288601	A1	9/2014	Baynham
2014/0336775	A1	11/2014	Reiley
2014/0343678	A1	11/2014	Suddaby et al.
2015/0080972	A1	3/2015	Chin
2015/0105828	A1	4/2015	Reckling
2015/0112444	A1	4/2015	Aksu
2015/0250612	A1	9/2015	Schifano
2015/0327872	A1	11/2015	Assell
2016/0081809	A1	3/2016	Schneider
2016/0081810	A1	3/2016	Reiley
2016/0120661	A1	5/2016	Schell
2016/0128838	A1	5/2016	Assell
2016/0157897	A1	6/2016	Vaidya
2016/0287171	A1	10/2016	Sand
2016/0310188	A1	10/2016	Marino et al.
2016/0310197	A1	10/2016	Black et al.
2017/0007409	A1	1/2017	Mauldin
2017/0296344	A1	10/2017	Souza
2017/0296346	A1	10/2017	Assell
2017/0325845	A1	11/2017	Donner et al.
2018/0008428	A1	1/2018	Larson
2018/0092669	A1	4/2018	Donner et al.
2018/0104071	A1	4/2018	Reckling
2018/0296347	A1	10/2018	Hamzey
2018/0303520	A1	10/2018	Rajpal
2018/0325675	A1	11/2018	Donner
2018/0325676	A1	11/2018	Donner
2018/0360608	A1	12/2018	Aksu
2019/0209011	A1	7/2019	Donner et al.
2019/0343640	A1	11/2019	Donner et al.

## FOREIGN PATENT DOCUMENTS

CN	201073333	Y	6/2008
CN	201139628		10/2008
CN	201275132		7/2009
CN	201275133		7/2009
CN	201275134		7/2009
CN	202235633	U	5/2012
DE	102013011322	A1	5/2014
EP	1663037	B1	6/2006
JP	2007-275592		10/2007
KR	10-1037206		5/2011
RU	2364359	C1	8/2009
WO	WO 1993/008745	A1	5/1993
WO	WO 1995/023559		9/1995
WO	WO 1995/031947		11/1995
WO	WO 1998/048717		11/1998
WO	WO 01/30264	A2	5/2001
WO	WO 2001/095823	A1	12/2001
WO	WO 2002/067759	A2	9/2002
WO	WO 02/085182	A2	10/2002
WO	WO 2006/020463	A1	2/2006
WO	WO 2006/099270		9/2006
WO	WO 2007/022790	A1	3/2007
WO	WO 2007/115295	A2	10/2007
WO	WO 2008/011410	A2	1/2008
WO	WO 2008/088685	A2	7/2008
WO	WO 2008/089537	A1	7/2008
WO	WO 2009/011774	A2	1/2009
WO	WO 2009/029074	A1	3/2009
WO	WO 2009/108318	A2	9/2009
WO	WO 2010/045749	A1	4/2010
WO	WO 2010/065015	A1	6/2010
WO	WO 2010/108166	A1	9/2010
WO	WO 2010/104135	A2	2/2011
WO	WO 2011/056690	A2	5/2011
WO	WO 2011/066053	A2	6/2011
WO	WO 2011/087912	A1	7/2011
WO	WO 2011/091349	A2	7/2011
WO	WO 2012/015976	A1	2/2012
WO	WO 2013/020123	A2	2/2013
WO	WO 2013/166496	A1	11/2013
WO	WO 2014/055529	A2	4/2014
WO	WO 2014/074853	A1	5/2014

## OTHER PUBLICATIONS

Atlihan et al. Anatomy of the Posterior Iliac Crest as a Reference to Sacral Bar Insertion. *Clin Orthop* 2004;418:141-145.  
Baria, Dinah, "Sacroiliac Joint Biomechanics and Effects of Fusion" (2010). Open Access Dissertations. Paper 466. [http://scholarlyrepository.miami.edu/oa\\_dissertations](http://scholarlyrepository.miami.edu/oa_dissertations), 179 pages.

(56)

## References Cited

## OTHER PUBLICATIONS

- Belanger, et al. "Sacroiliac Arthrodesis Using a Posterior Midline Fascial Splitting Approach and Pedicle Screw Instrumentation: A New Technique." *Journal of Spinal Disorders*, vol. 14 No. 2, pp. 118-124, 2001.
- Buchowski, et al. "Functional and Radiographic Outcome of Sacroiliac Arthrodesis for the Disorders of the Sacroiliac Joint." *The Spine Journal*, 5, 2005, pp. 520-528.
- Cecil et al. Projection of the S2 Pedicle Onto the Posterolateral Surface of the Ilium: A Technique for Lag Screw Fixation, Sacral Fractures or Sacroiliac Joint Dislocations. *Spine* 1996;21(7):875-878.
- Chang et al. Low Profile Pelvic Fixation. *Spine* 2009;34(5):436-440.
- Dall et al., *Surgery for the Painful, Dysfunctional Sacroiliac Joint*, Springer International Publishing, Switzerland, 2015.
- Dayer R. et al. Pelvic fixation for neuromuscular scoliosis deformity correction. *Curr Rev Musculoskelet Med* (2012) 5:91-101.
- DePuy Spine. ISOLA® Spinopelvic System, Surgical Technique. c. 2003 DePuy Spine, Inc., 28 pages.
- Ebraheim, et al. "A Posterior Approach for Inspection of Reduction of Sacroiliac Joint Disruption." *Surg. Radiol. Anat.*, 1999, 21(5), pp. 305-307.
- Ebraheim, et al. "Anatomic considerations for Posterior Approach to the Sacroiliac Joint." *Spine*, 21(23), Dec. 1, 1996, pp. 2709-2712.
- Garrido B.J. et al. Navigated placement of iliac bolts: description of a new technique. *The Spine Journal* 11 (2011) 331-335.
- Giannikas, et al. "Sacroiliac Joint Fusion for Chronic Pain: A Simple Technique Avoiding the Use of Metalwork." *Eur. Spine J*, 13, 2004, pp. 253-256.
- Globus Medical. Revere® Addition® Sacroiliac Components, Surgical Technique. c. 2012 Globus Medical, 64 pages.
- Globus Medical. SI-LOK™ Sacroiliac Joint Fixation System, Surgical Technique. c. 2011 Globus Medical, 44 pages.
- Globus Medical. Secure-C Cervical Artificial Disc. Copyright 2014.
- Guner, et al. "Anterior Sacroiliac Fusion. A New Video-Assisted Endoscopic Technique." *Surgical Laparoscopy & Endoscopy*. 1998; vol. 8, No. 3, pp. 233-236.
- LDR. Avenue® L Lateral Lumbar Cage. Sep. 2011, 3 pages.
- LDR. ROI-A™ Anterior Approach Implant. Apr. 2008, 2 pages.
- LDR. Surgical Technique ROI-C™ Anterior Cervical Cage. Apr. 2010, 15 pages.
- Lee et al. Trajectory of Transsacral Iliac Screw for Lumbopelvic Fixation. *J Spinal Disord Tech* 2011;24(3):151-156.
- Lehman, Jr. et al. Advantage of Pedicle Screw Fixation Directed Into the Apex of the Sacral Promontory Over Bicortical Fixation. *Spine* 2002;27(8):806-811.
- Liebergall, Meir (Iri) M.D., *Lumbosacral and Spinopelvic Fixation*, Lippincott-Raven, Philadelphia, PA, 1996, Chap. 48, "Sacroiliac Joint Fusion," pp. 611-618.
- Luk et al. A Stronger Bicortical Sacral Pedicle Screw Fixation Through the S1 Endplate. *Spine* 2005;30(5):525-529.
- Margulies, J.Y. et al., *Movement, Stability & Low Back Pain, The essential role of the pelvis*, Churchill Livingstone, London, 1997, Chapters 44-47, "Surgical Fusion of the Spine to the Sacrum, etc.," pp. 555-593.
- Marotta N. et al. A novel minimally invasive presacral approach and instrumentation technique for anterior L5-S1 intervertebral disectomy and fusion. *Neurosurg Focus*, vol. 20, Jan. 2006, 8 pages.
- Martin et al. Sacropelvic Fixation: Two Case Reports of a New Percutaneous Technique. *Spine* 2011;36(9):E618-21.
- McLauchlan, et al. "Sacral and Iliac Articular Cartilage Thickness and Cellularity: Relationship to Subchondral Bone End-Plate Thickness and Cancellous Bone Density." *Rheumatology* 2002; 41:375-380.
- Medtronic Sofamor Danek. Colorado 2™ Sacro-Iliac Fixation, Surgical Technique. © 2003 Medtronic Sofamor Danek USA, Inc. Medtronic Sofamor Danek. Colorado 2™ The New Revolution, Surgical Technique. © 2000 Medtronic Sofamor Danek, Inc.
- Mendel et al. The Lateral Sacral Triangle—A Decision Support for Secure Transverse Sacroiliac Screw Insertion. *Injury J. Care Injured* 2010;42(2011):1164-1170.
- Moshirfar et al. Pelvic Fixation in Spine Surgery. *The Journal of Bone & Joint Surgery* 2005;87-A(2 Suppl):89-106.
- O'Brien et al. An Anatomic Study of the S2 Iliac Technique for Lumbopelvic Screw Placement. *Spine* 2009;34(12):E439-E442.
- O'Brien et al. Feasibility of Minimally Invasive Sacropelvic Fixation. *Spine* 2010;35(4):460-464.
- O'Brien et al. Sacropelvic Instrumentation: Anatomic and Biomechanical Zones of Fixation. *Seminars in Spine Surgery* 2004;16(2):76-90.
- Ouellet et al. Surgical Anatomy of the Pelvis, Sacrum, and Lumbar Spine Relevant to Spinal Surgery. *Seminars in Spine Surgery* 2004 Elsevier Inc.;16:91-100.
- Pan W. et al. The invention of an iliosacral screw fixation guide and its preliminary clinical application. *Orthopaedic Surgery* (2012), vol. 4, No. 1, pp. 55-59.
- Puhakka, et al. "MR Imaging of the Normal Sacroiliac Joint with Correlation to Histology." *Skeletal Radiol.*, 33, 2004, pp. 15-28.
- SI-BONE iFuse Implant System, Surgical Technique Manual. c. 2011 SI-BONE, Inc., 35 pages.
- SI-BONE iFuse Implant System™. SI-BONE, Inc. 2010, 4 pages.
- Signus Medizintechnik GmbH. DIANA Operationstechnik. Rev. May 1, 2010, 20 pages.
- Sponseller P.D. et al. Low profile pelvic fixation with the sacral alar iliac technique in the pediatric population improves results at two-year minimum follow-up. *Spine*. 2010; vol. 35, No. 20, pp. 1887-1892.
- Stark J. G. et al. The history of sacroiliac joint arthrodesis: a critical review and introduction of a new technique. *Current Orthopaedic Practice*, vol. 22, No. 6, Nov./Dec. 2011, pp. 545-557.
- Stark. "The Diagnosis and Treatment of Sacroiliac Joint Abnormalities." *Current Orthopedic Practice*, 21(4), Jul./Aug. 2010, pp. 336-347.
- Synthes GmbH. Sacral Bars. Fixation of the posterior pelvis in cases of fractures or sacroiliac joint dislocations. © Apr. 2009 Synthes, Inc.
- Synthes Spine. ProDisc-C Total Disc Replacement. Product Information. © 2008 Synthes, Inc., 14 pages.
- Synthes Spine. SynFix-LR System. Instruments and implants for stand-alone anterior lumbar interbody fusion (ALIF). Technique Guide. © 2008 Synthes, Inc., 45 pages.
- Synthes Spine. ProDisc-L Total Disc Replacement. For replacement of a diseased and/or degenerated intervertebral disc of the lumbosacral regions. Technique Guide. Copyright 2006.
- Synthes Spine. Universal Spinal System (USS) Polyaxial and Iliosacral Spine Fixation. A versatile system for posterior stabilization of spinal segments. Technique Guide, c. 2009 Synthes, Inc., 61 pages.
- Szadek, et al. "Possible Nociceptive Structures in the Sacroiliac Joint Cartilage: An Immunohistochemical Study." *Clinical Anatomy*, 23, 2010, pp. 192-198.
- Tenon Medical, *Catamaran SI Joint Implant*, <http://tctig.com/projects> (last visited Nov. 19, 2014).
- Tifix® Technology Pressure Plate Technology: Multidirectional Locking Technology Titanium Plate and Screw Systems, General & Specific Instructions. litos/GmbH & Co. KG, Rev. Sep. 9, 2008.
- Tobler W.D. et al. The presacral retroperitoneal approach for axial lumbar interbody fusion. *J Bone Joint Surg [Br]*, vol. 93-B, No. 7, Jul. 2011, pp. 955-960.
- Ugur, et al. "New Needle Holder Facilitates Percutaneous Fluoroscopy-Guided Sacroiliac Puncture." *Acta Radiologica*, 2006, 47(5), pp. 481-483.
- Vanelderen, et al. "Evidence-Based Medicine. Evidence-Based Interventional Pain Medicine According to Clinical Diagnoses. 13. Sacroiliac Joint Pain." *Pain Practice*, 10(5), 2010, pp. 470-478.
- Waisbrod, et al. "Sacroiliac Joint Arthrodesis for Chronic Lower Back Pain." *Arch. Orthop. Trauma Surg.*, 106, 1987, pp. 238-240.
- Wise, et al. "Minimally Invasive Sacroiliac Arthrodesis. Outcomes of a New Technique." *Spinal Disord. Tech.*, 21(8), Dec. 2008, pp. 579-584.
- Yin, et al. "Sensory Stimulation-Guided Sacroiliac Joint Radiofrequency Neurotomy: Technique Based on Neuroanatomy of the Dorsal Sacral Plexus." *Spine* 2003; vol. 28, No. 20, pp. 2419-2425.

(56)

**References Cited**

OTHER PUBLICATIONS

Zyga Technology, Inc. Slimmetry Sacroiliac Joint Fusion System, Surgeon Didactic, c. 2012 Zyga Technology, Inc., 45 pages.

Zyga Technology, Inc. Slimmetry Sacroiliac Joint Fusion System, Technique Guide, known at least as early as Mar. 1, 2013, 20 pages.

\* cited by examiner

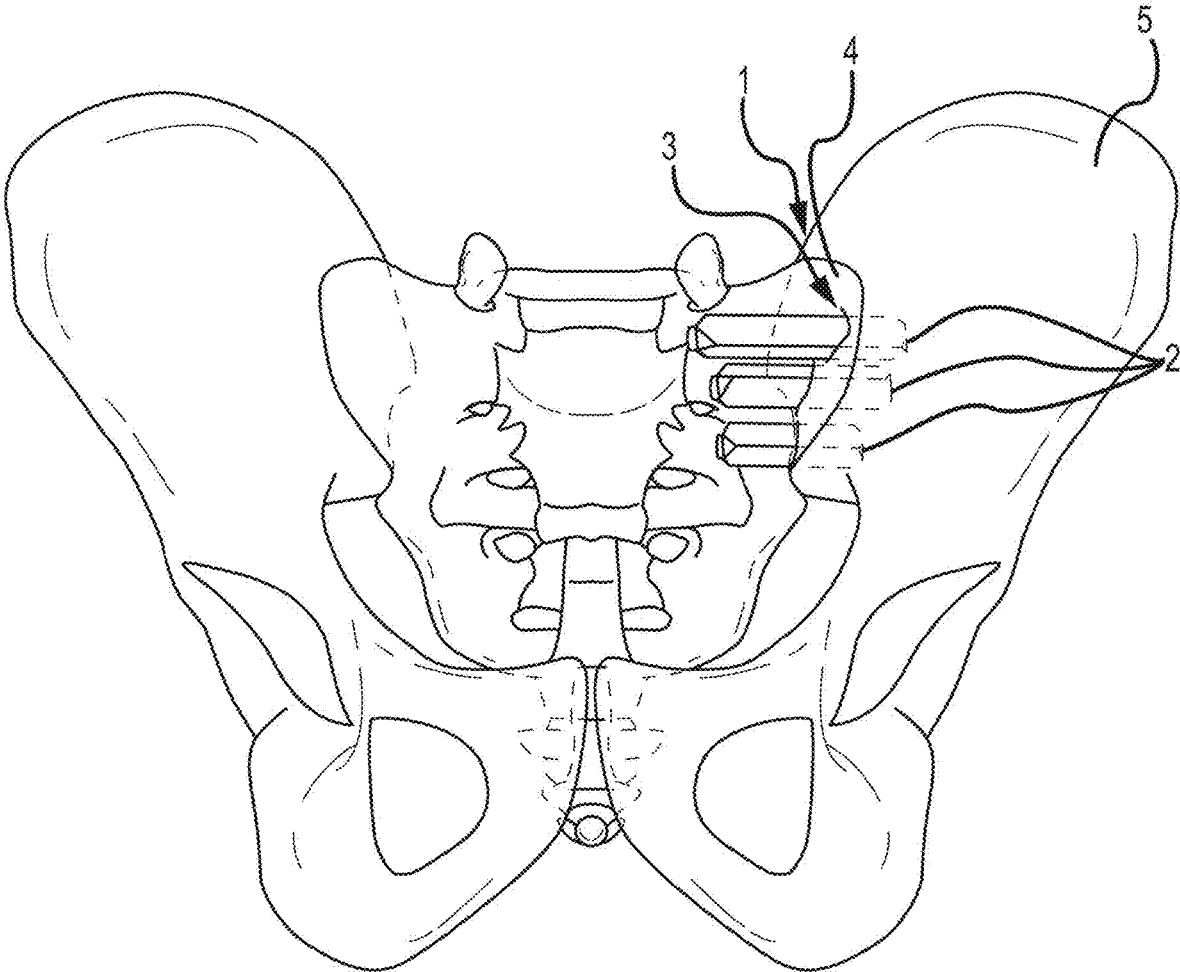

**FIG. 1**  
CONVENTIONAL ART



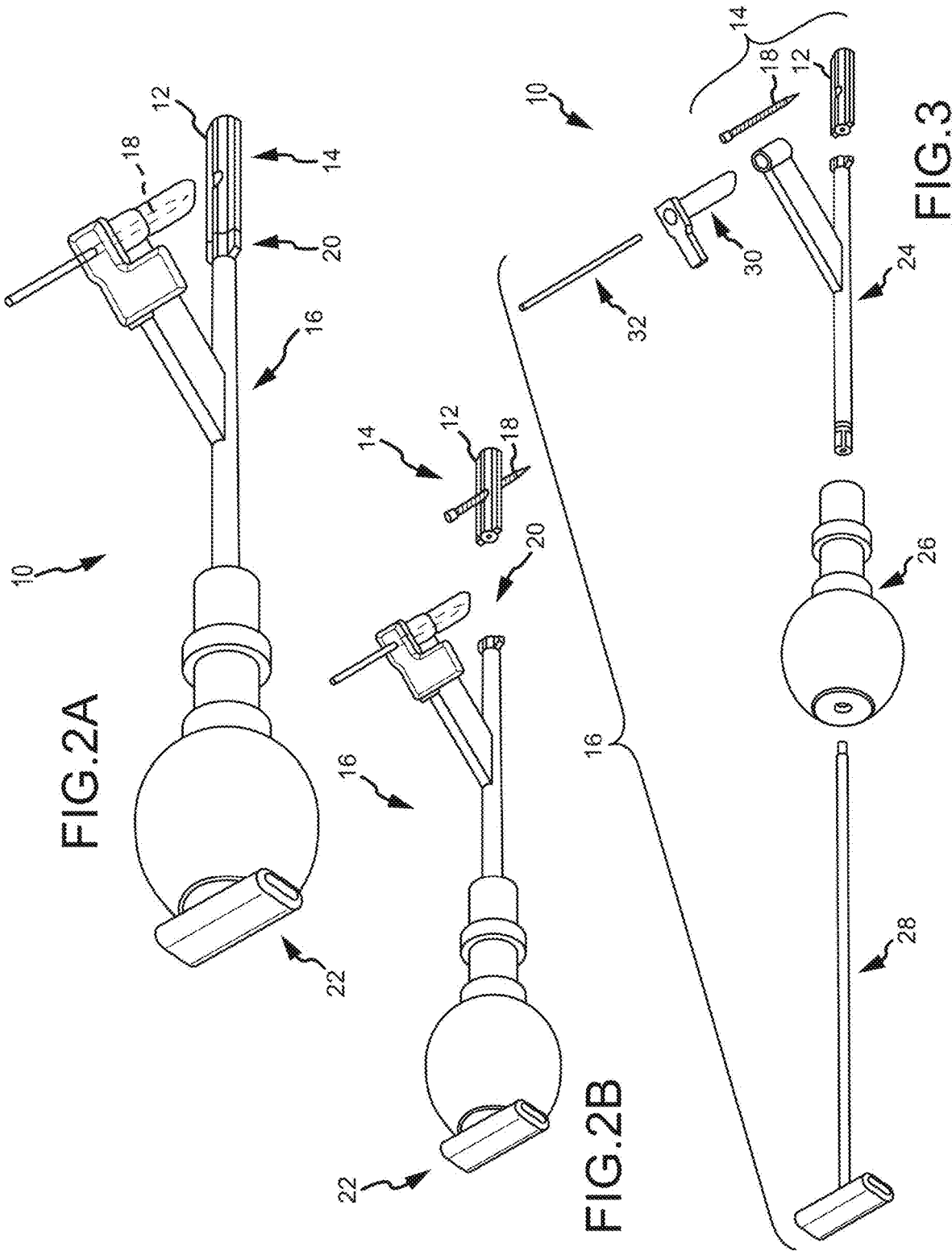

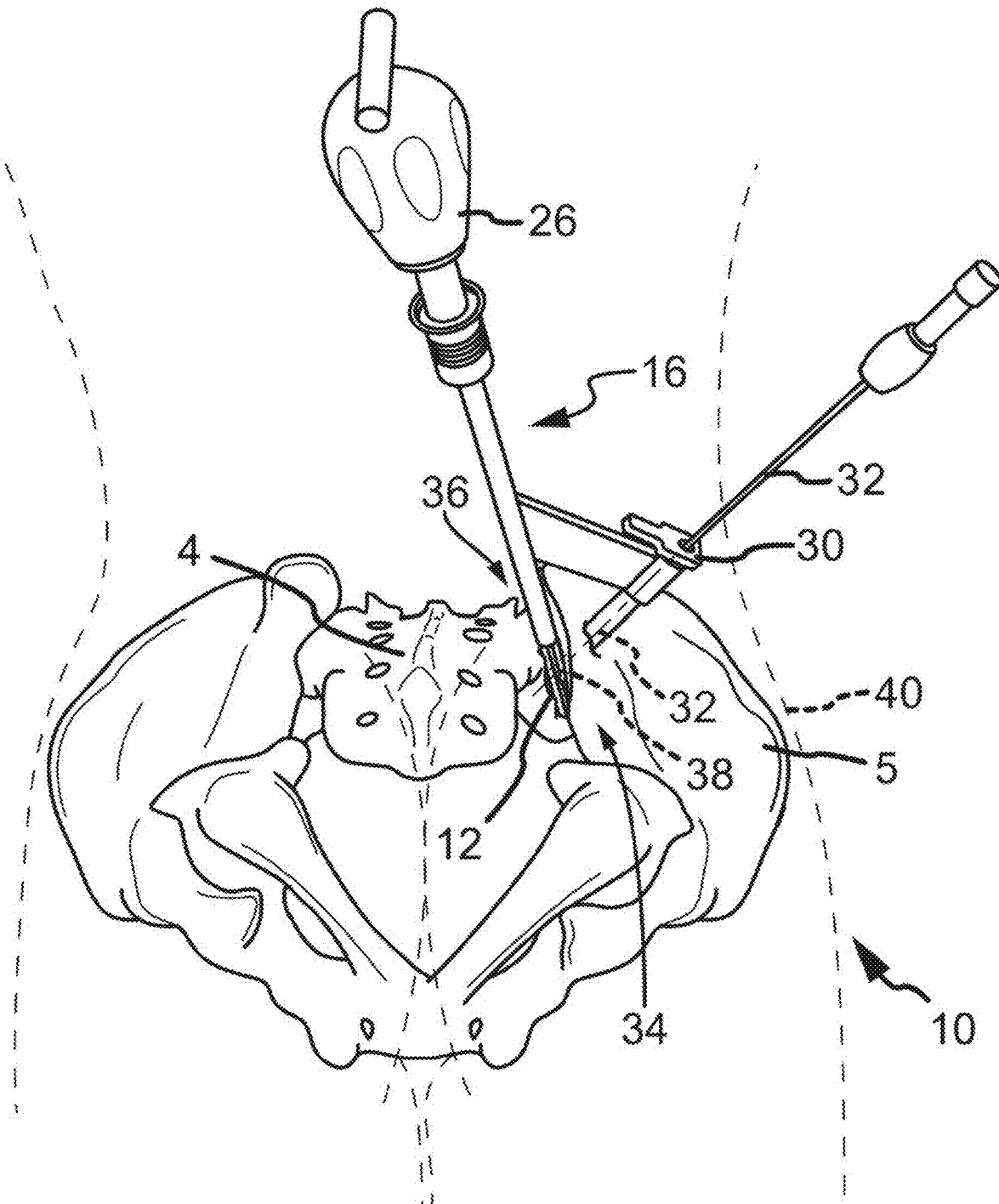

FIG. 4

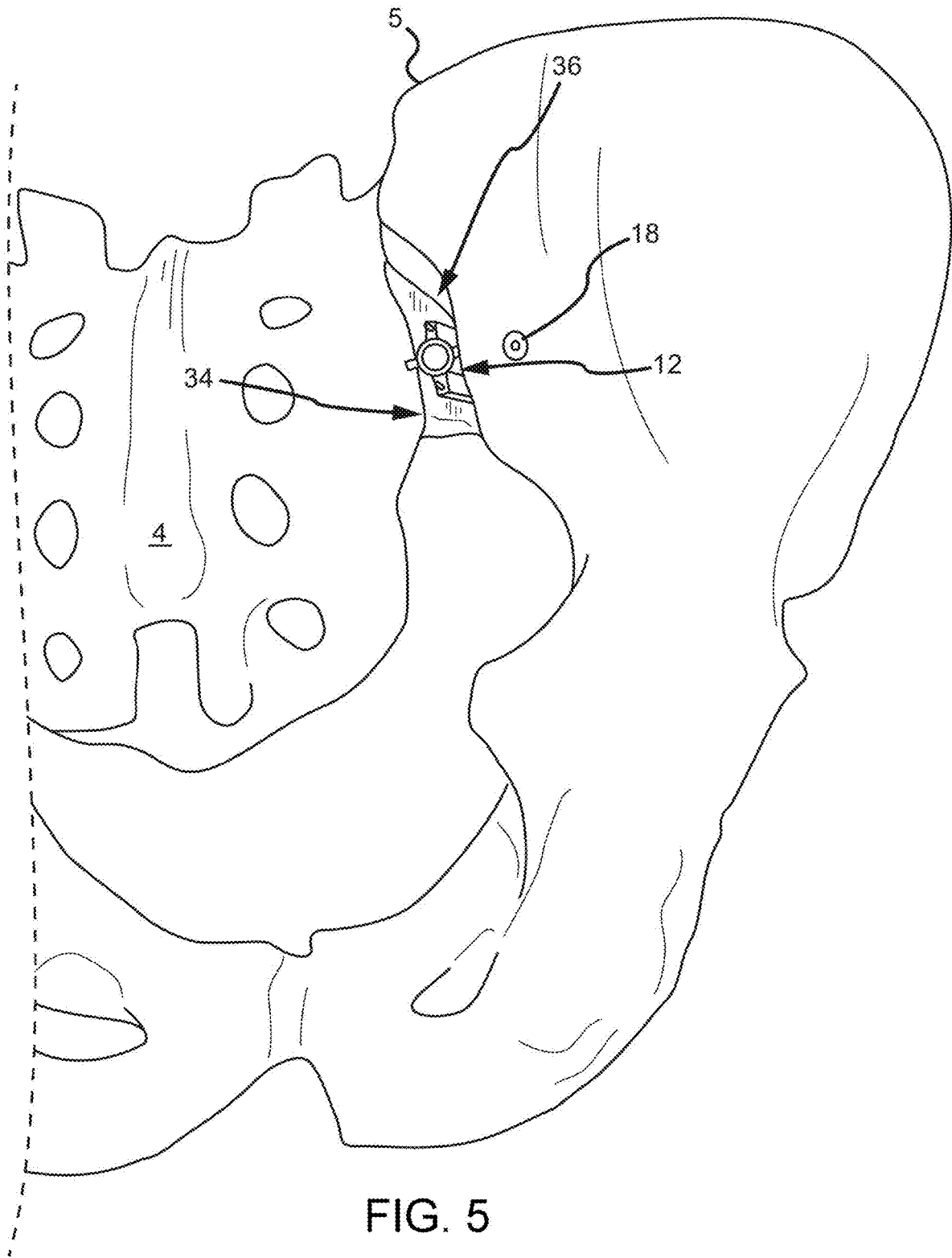

FIG. 5

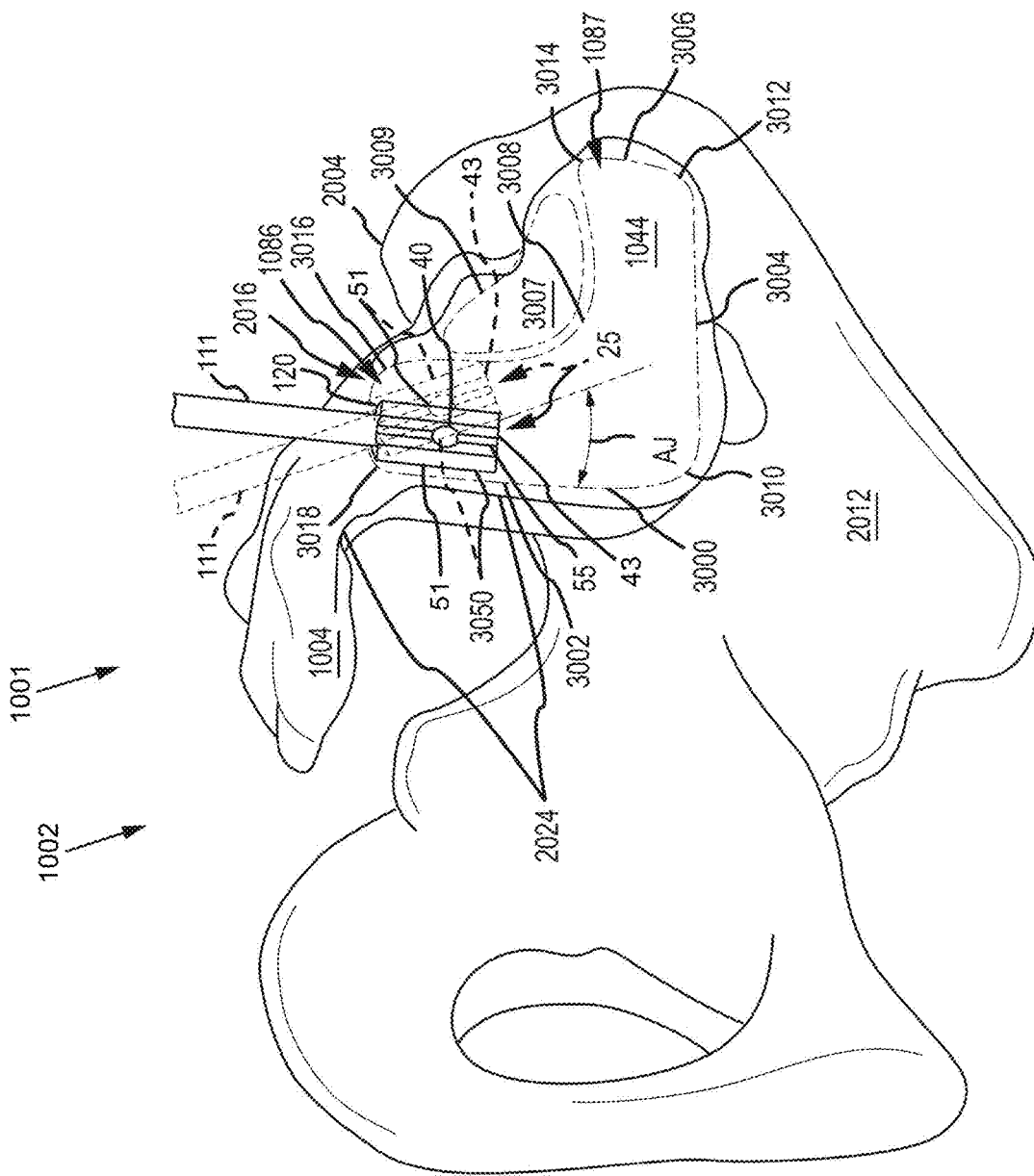

FIG. 6

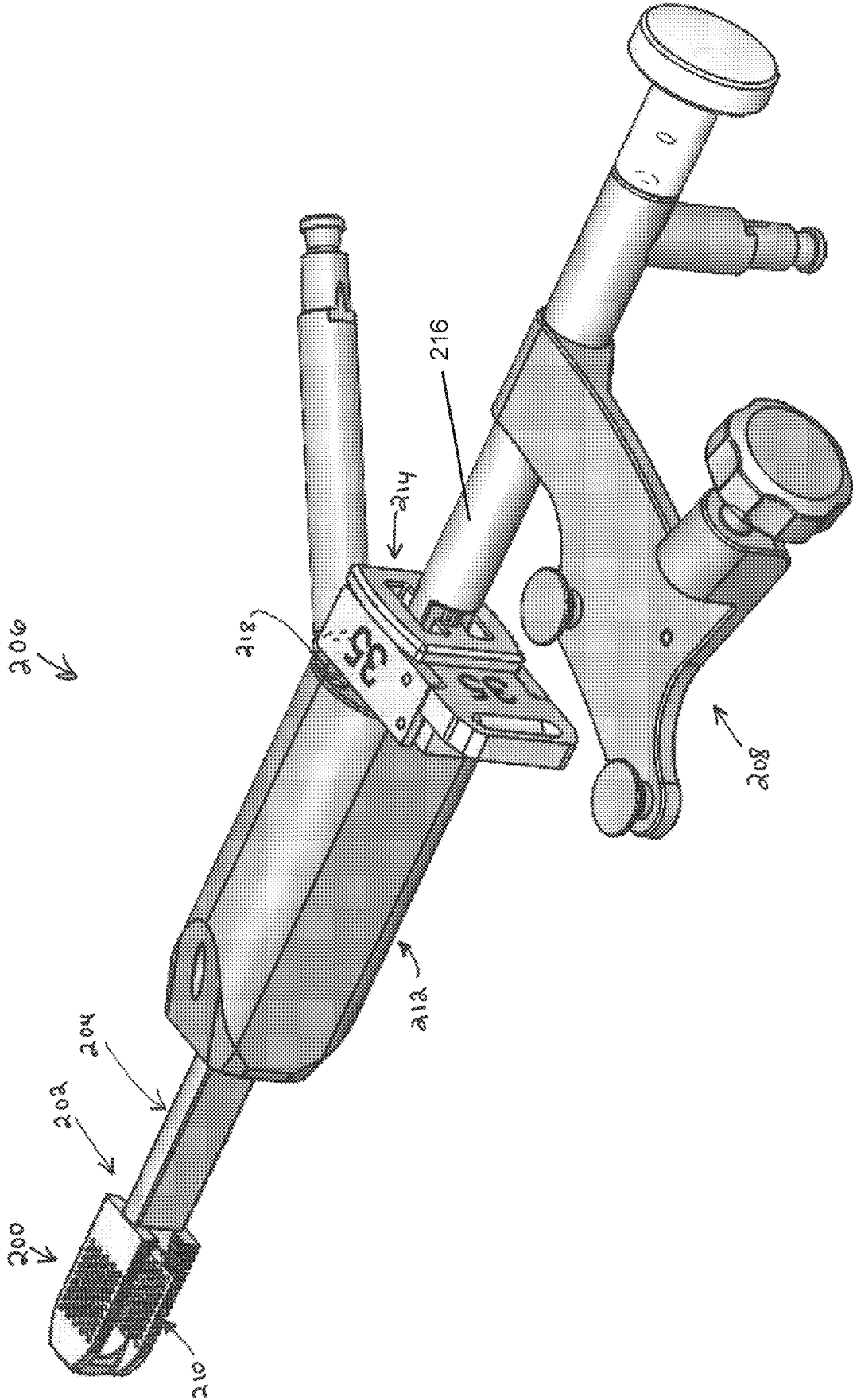

FIG. 7

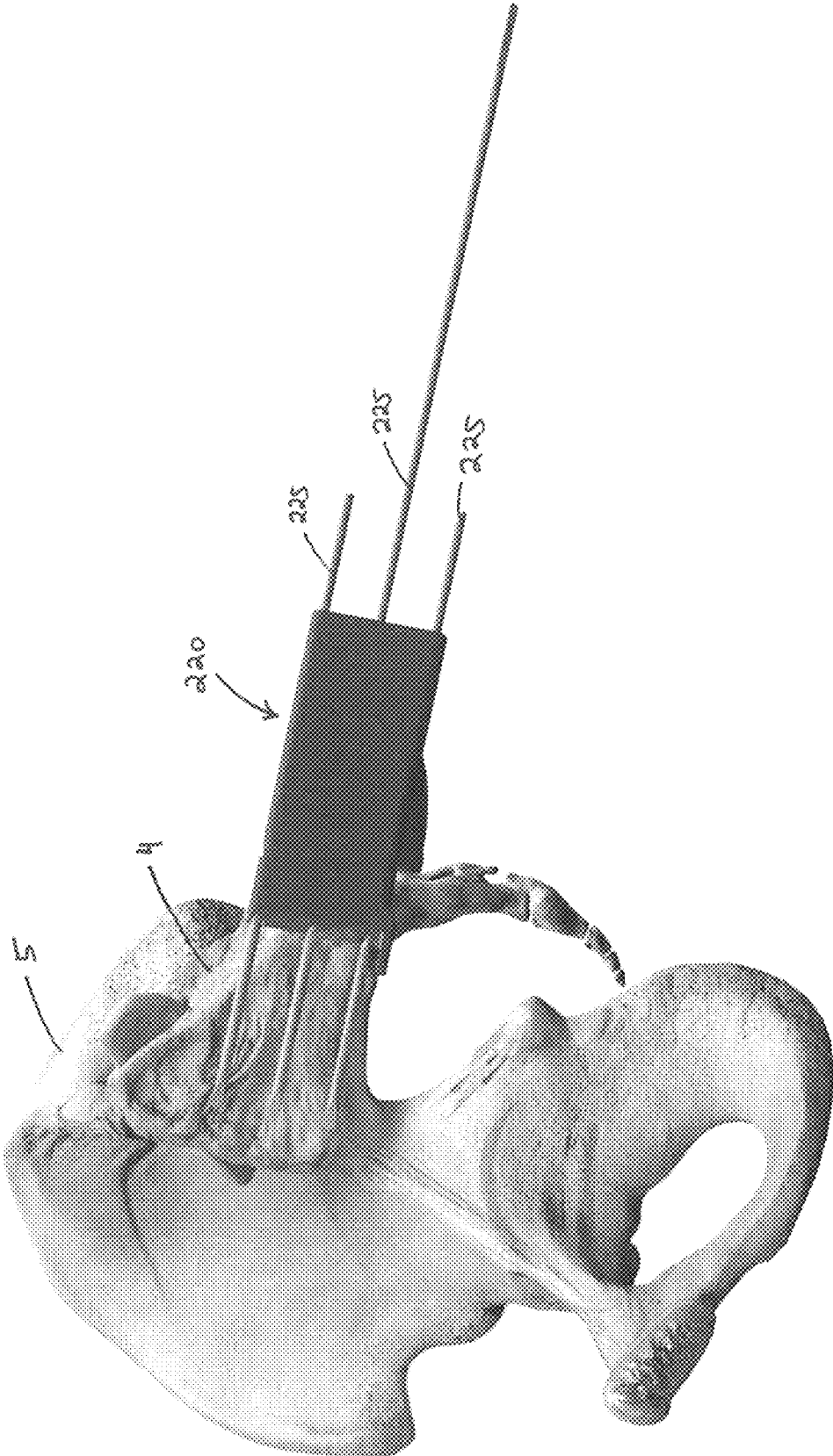

FIG. 8

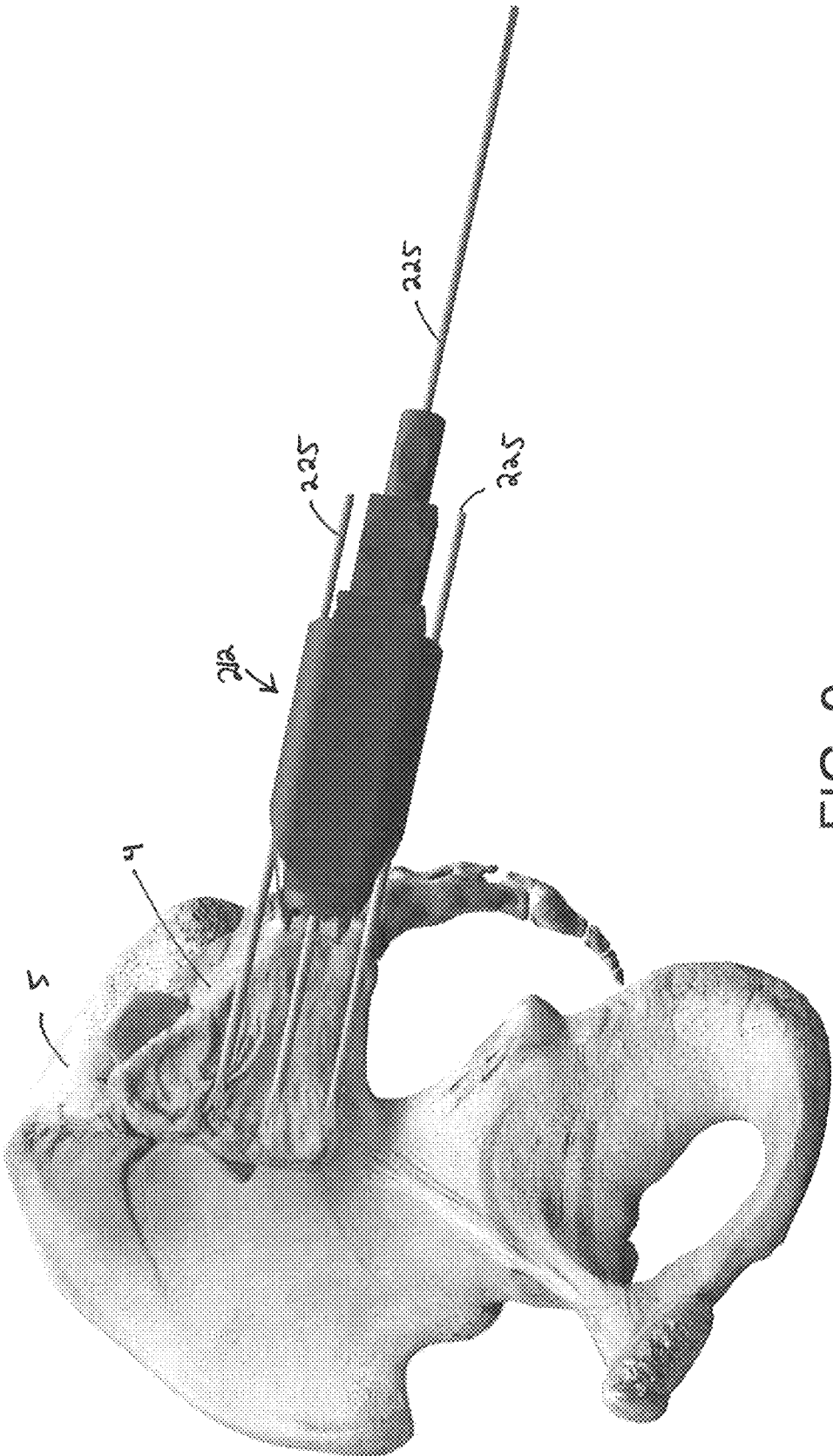

FIG. 9

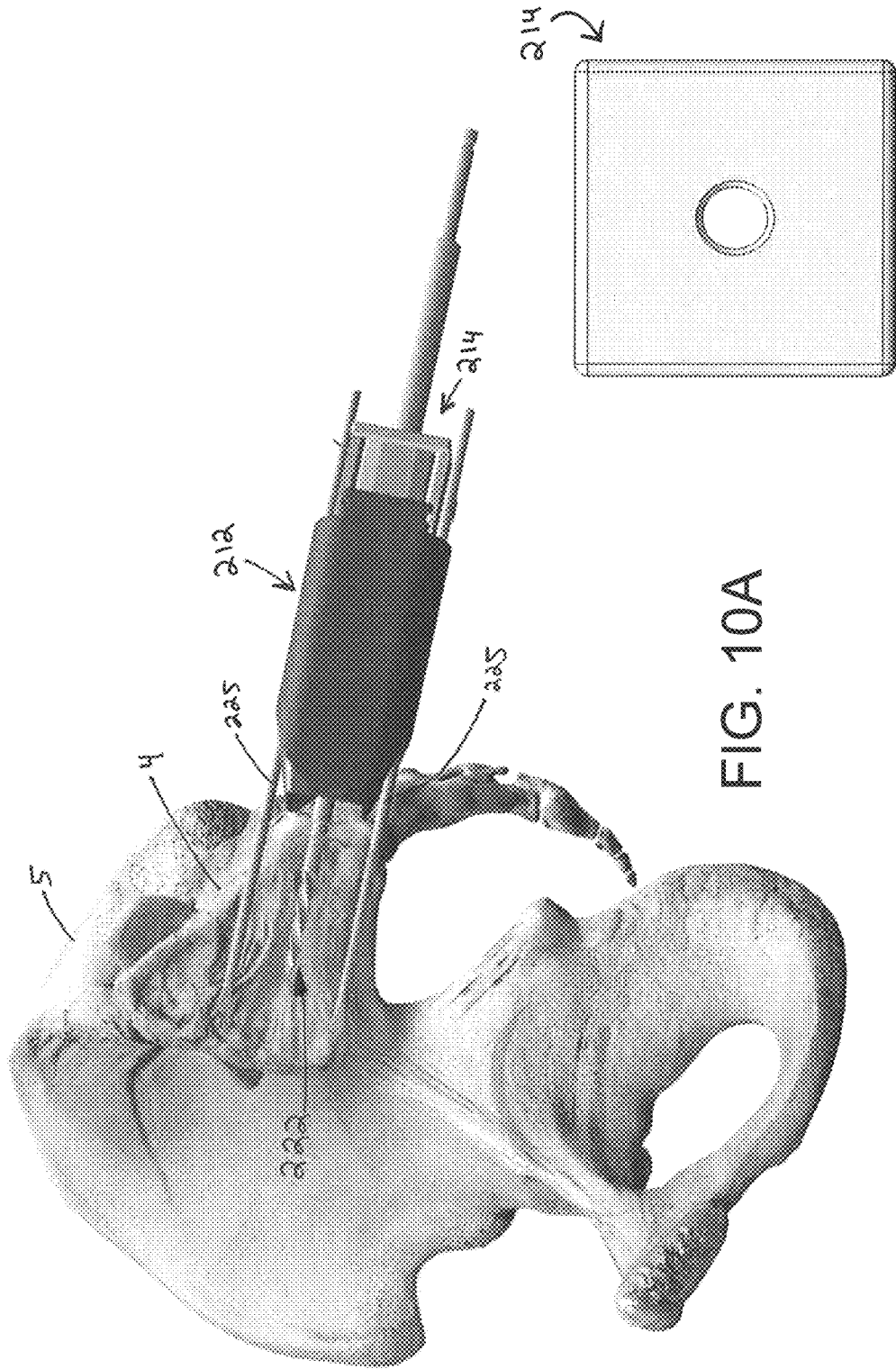

FIG. 10A

FIG. 10B



FIG. 11B

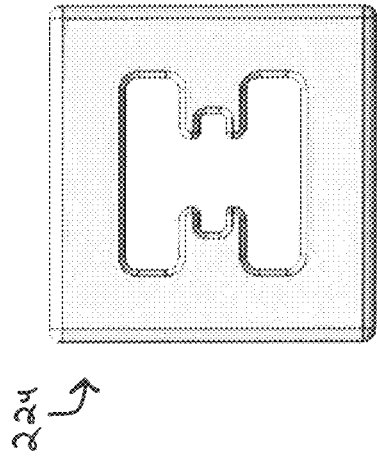

FIG. 11A

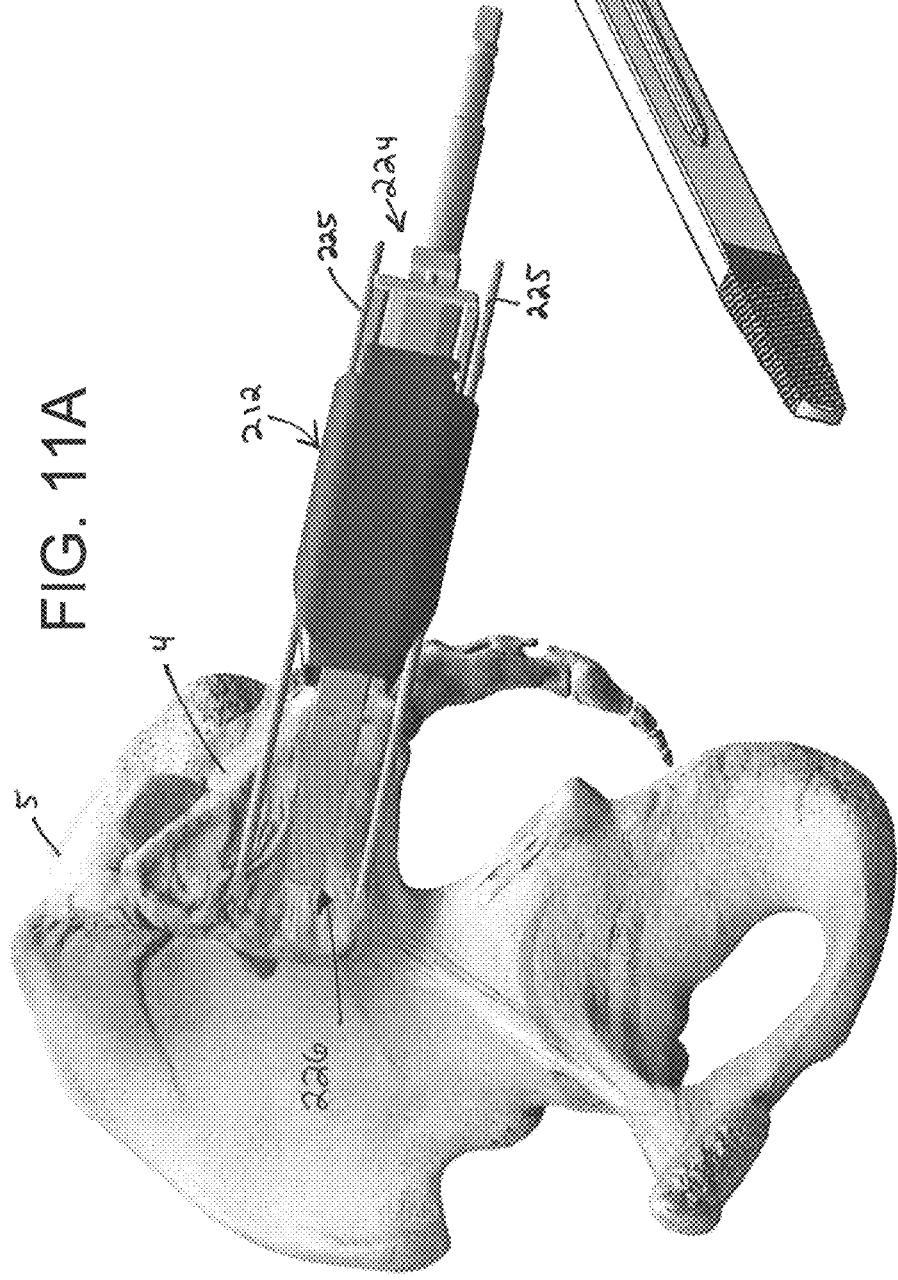
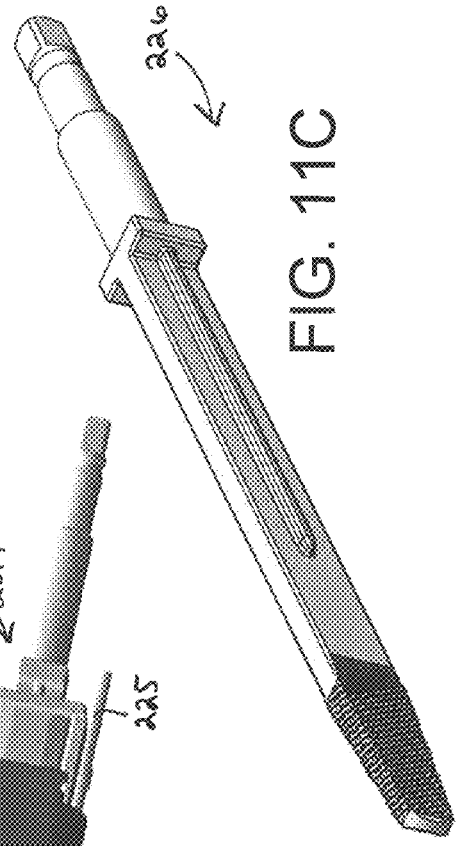

FIG. 11C



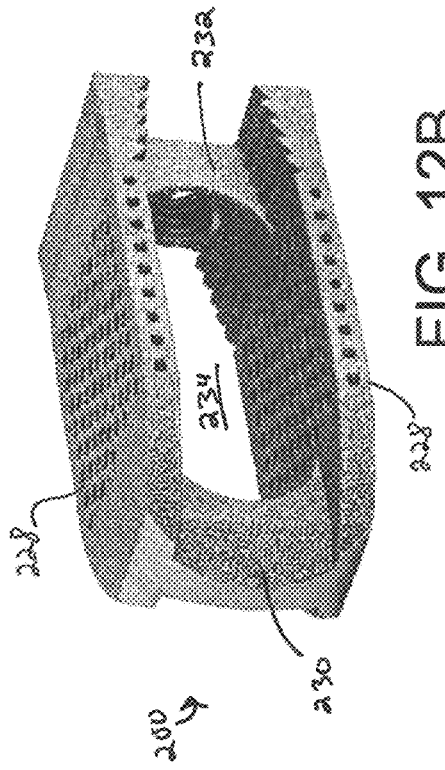

FIG. 12B

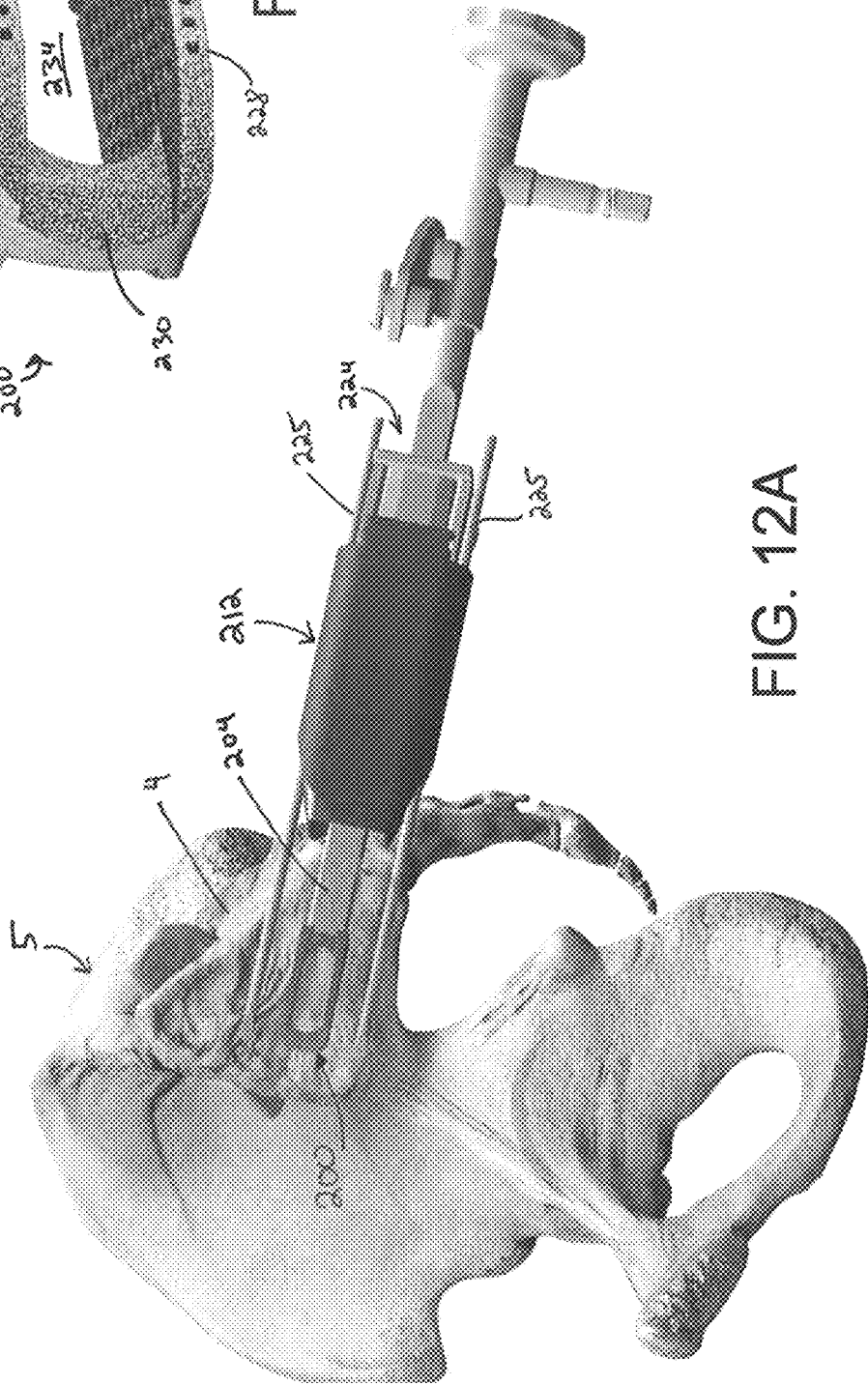

FIG. 12A

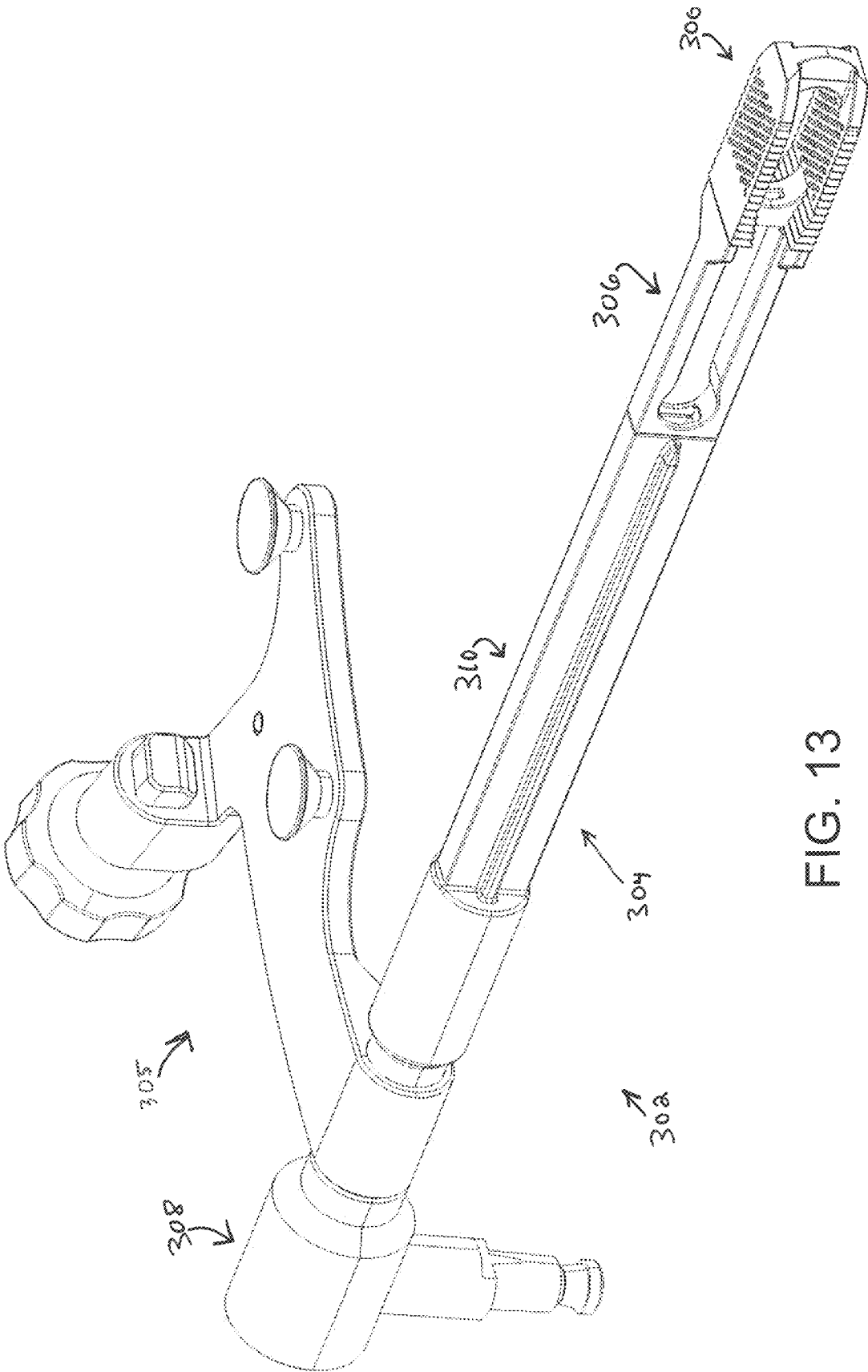

FIG. 13

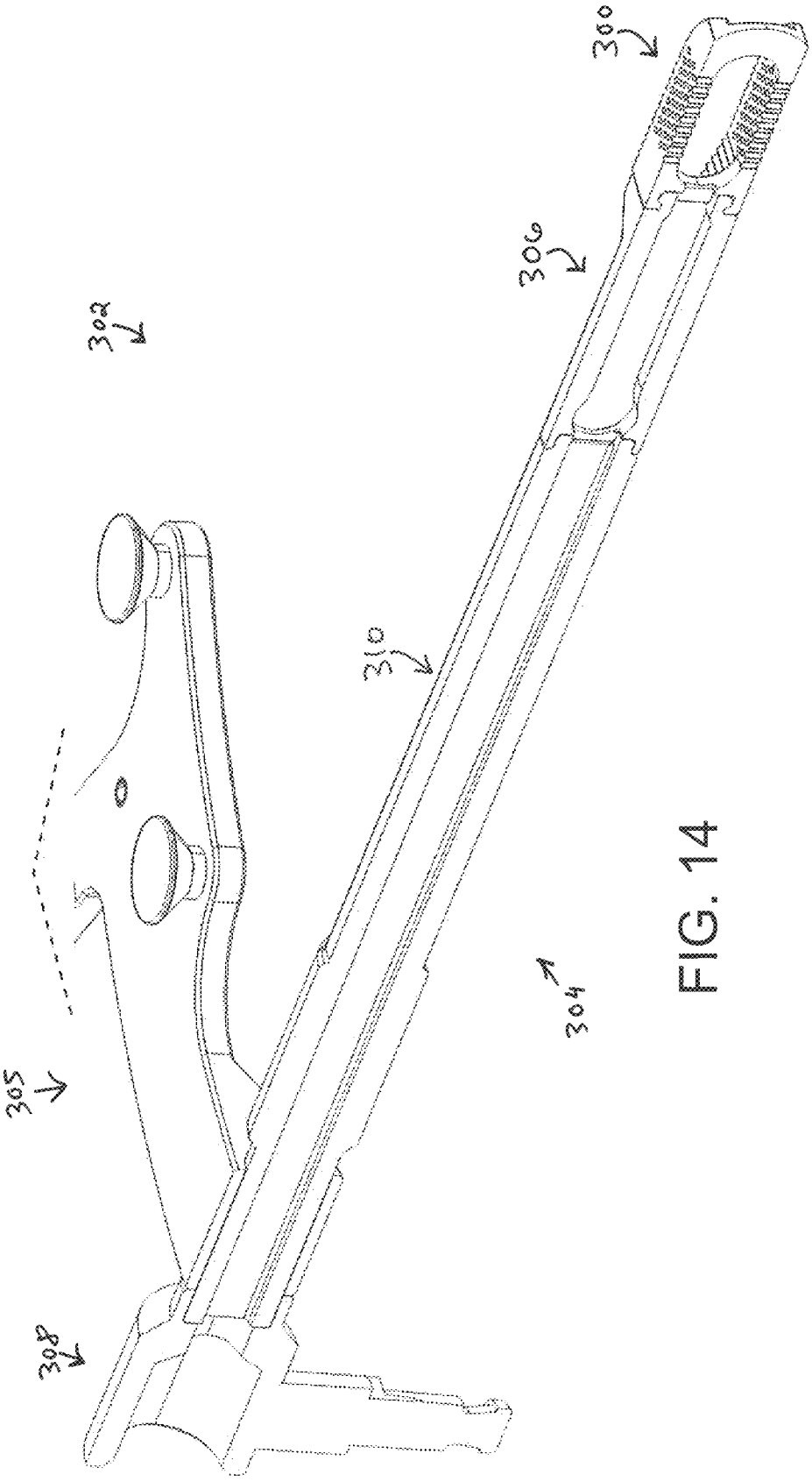

FIG. 14

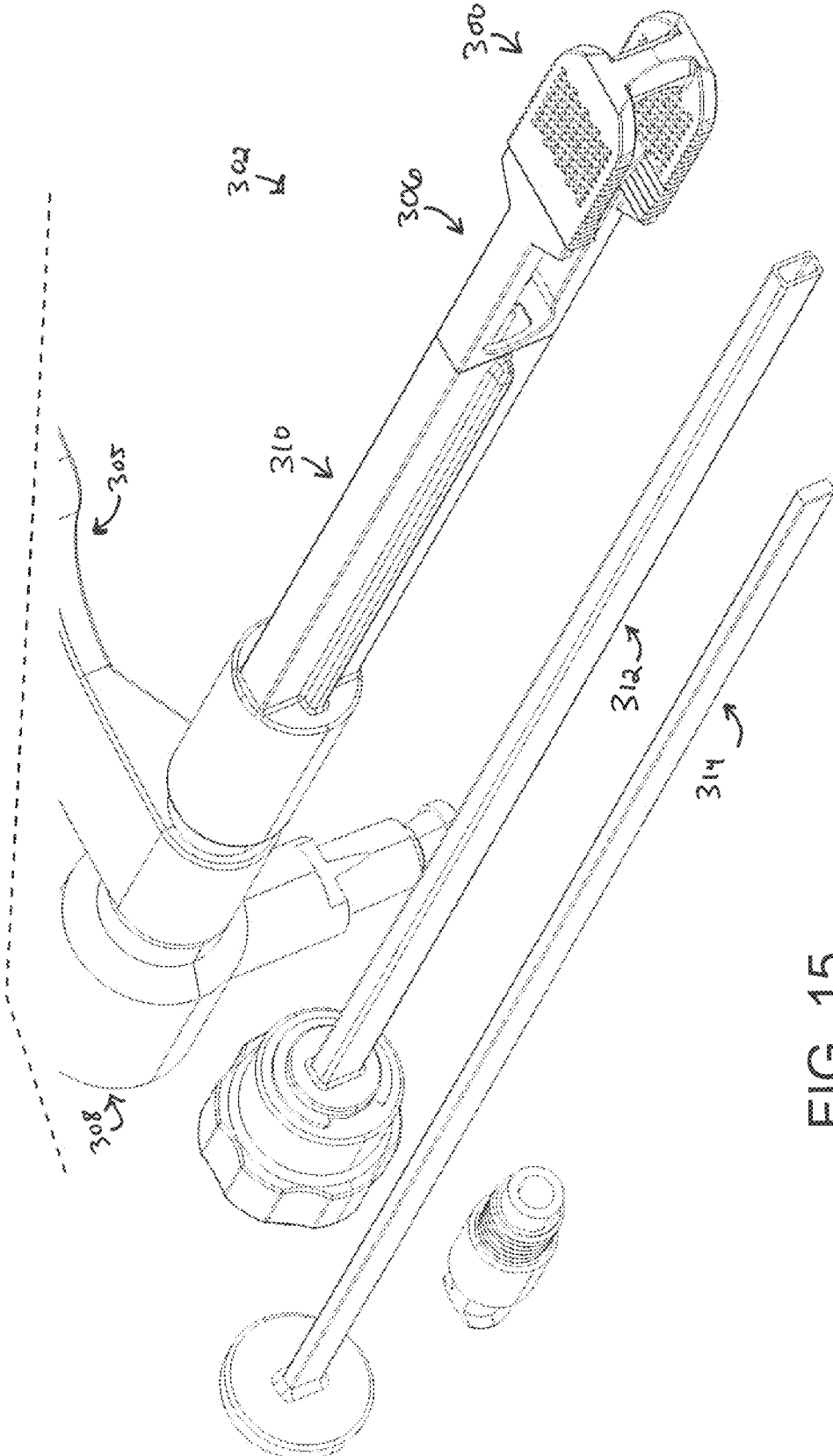

FIG. 15

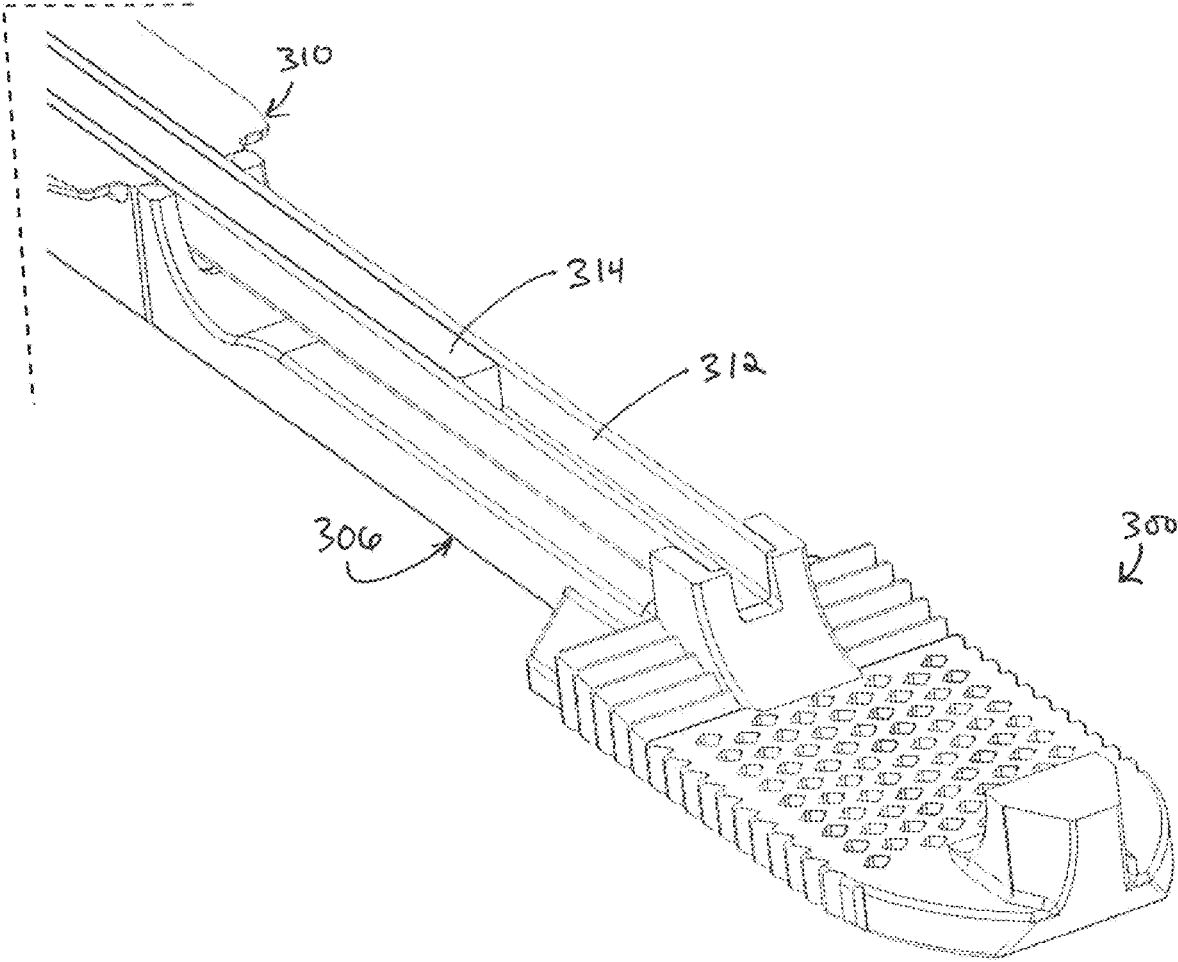

FIG. 16

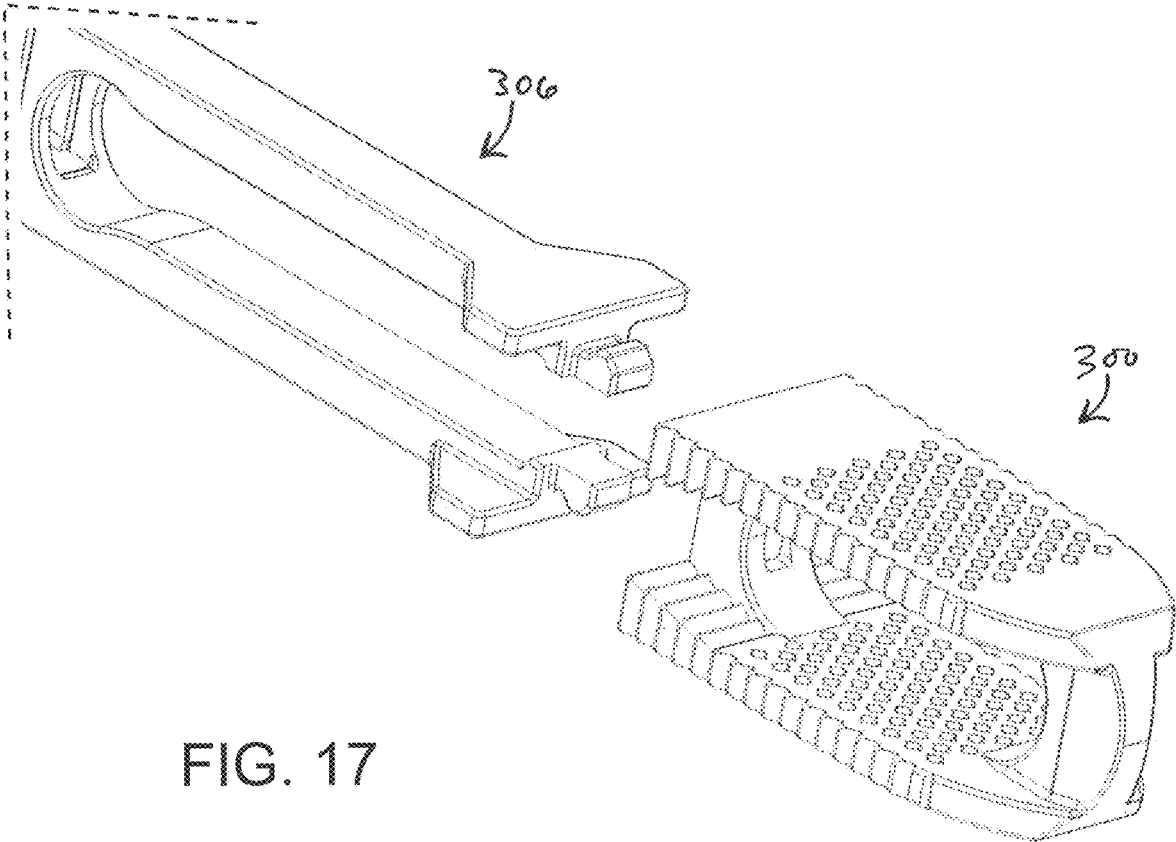

FIG. 17

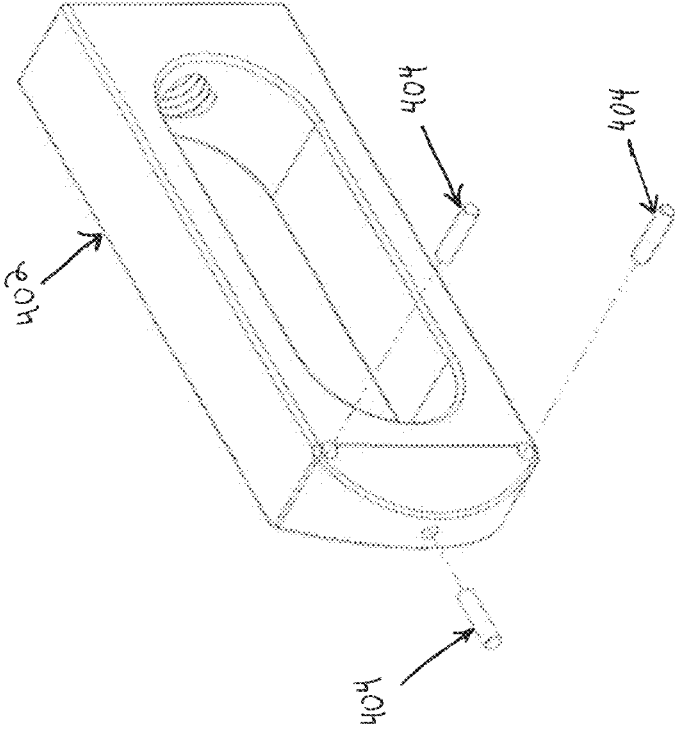

FIG. 18



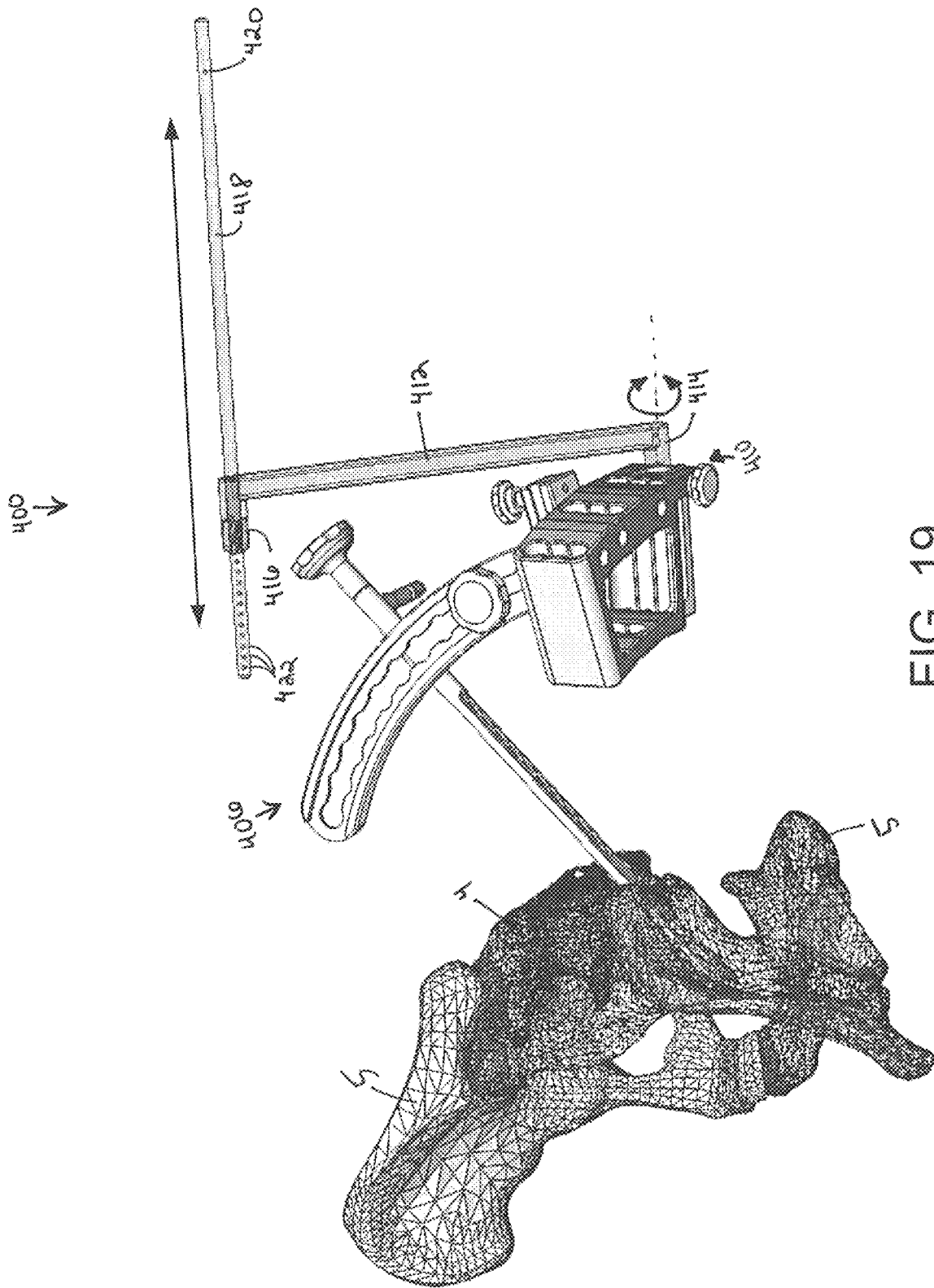

FIG. 19

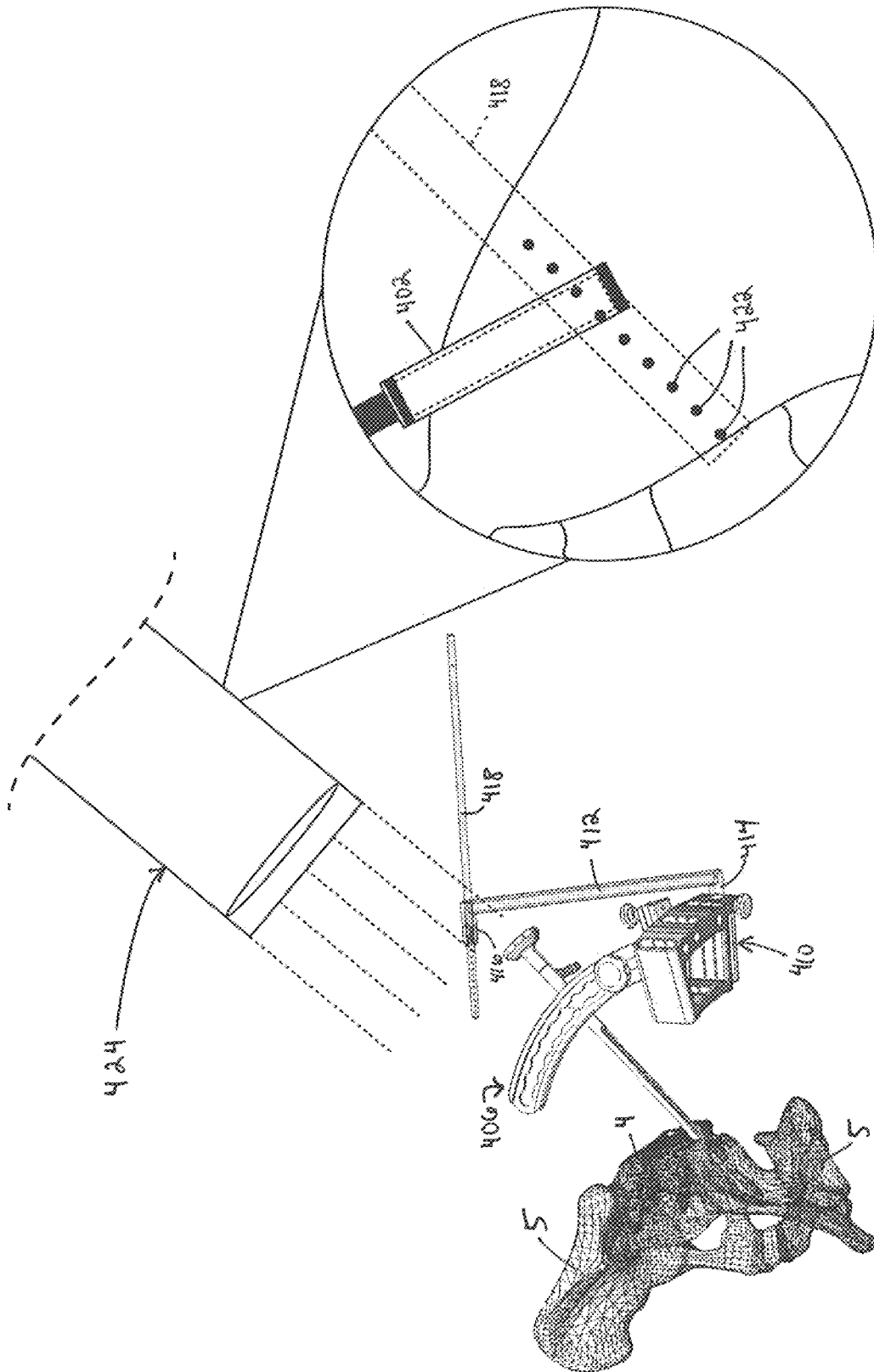

FIG. 20

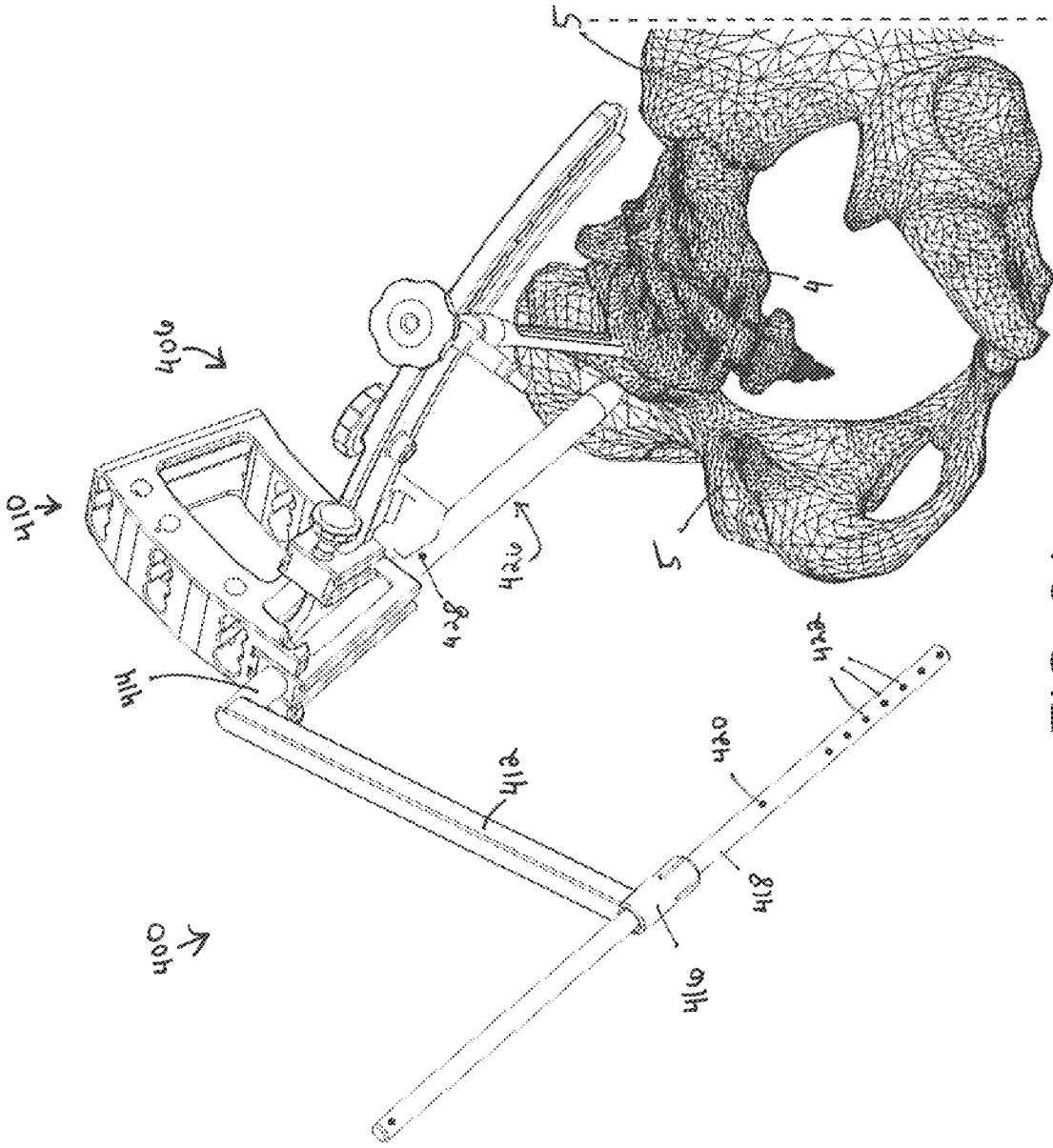

FIG. 21

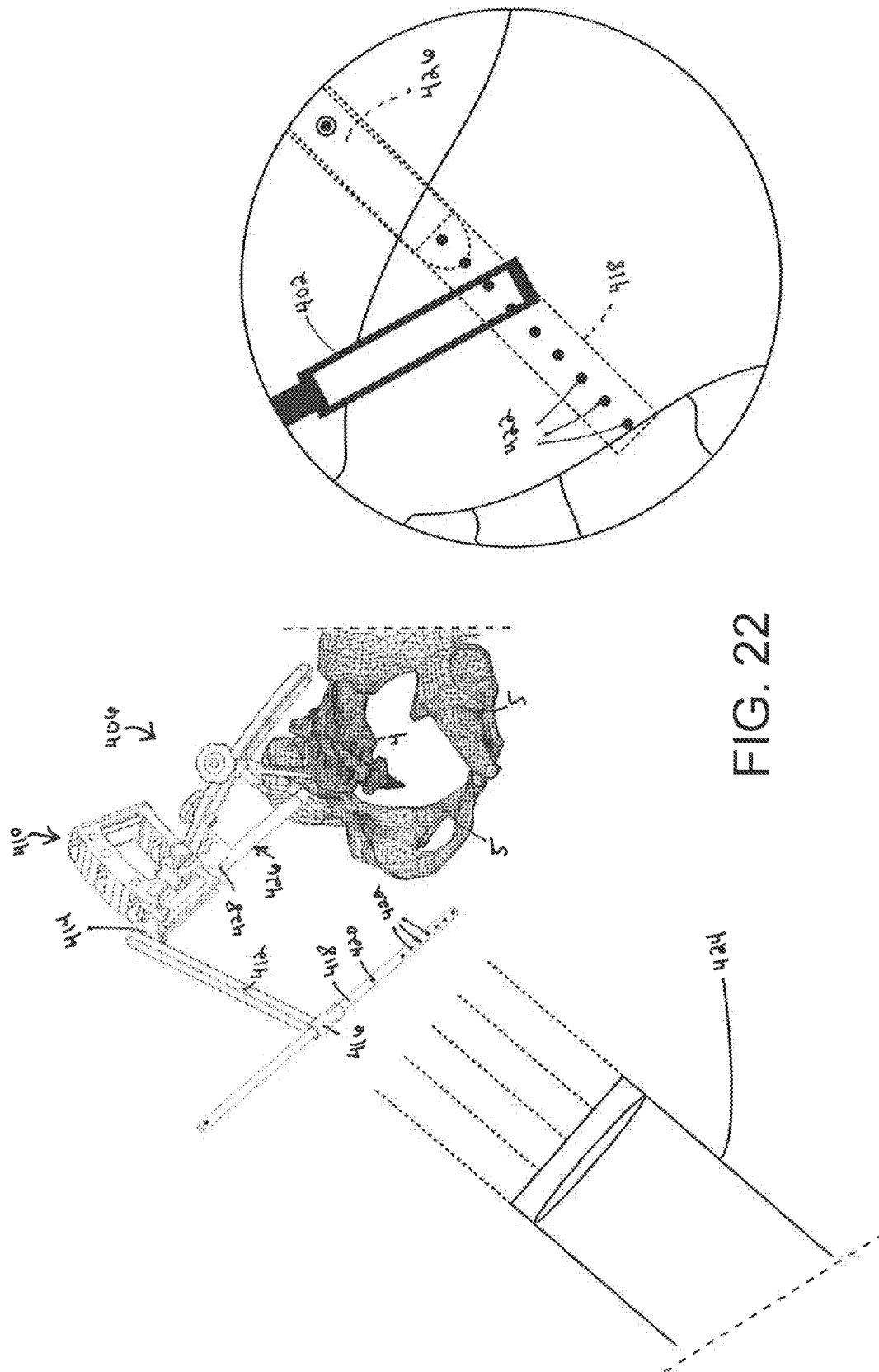

FIG. 22

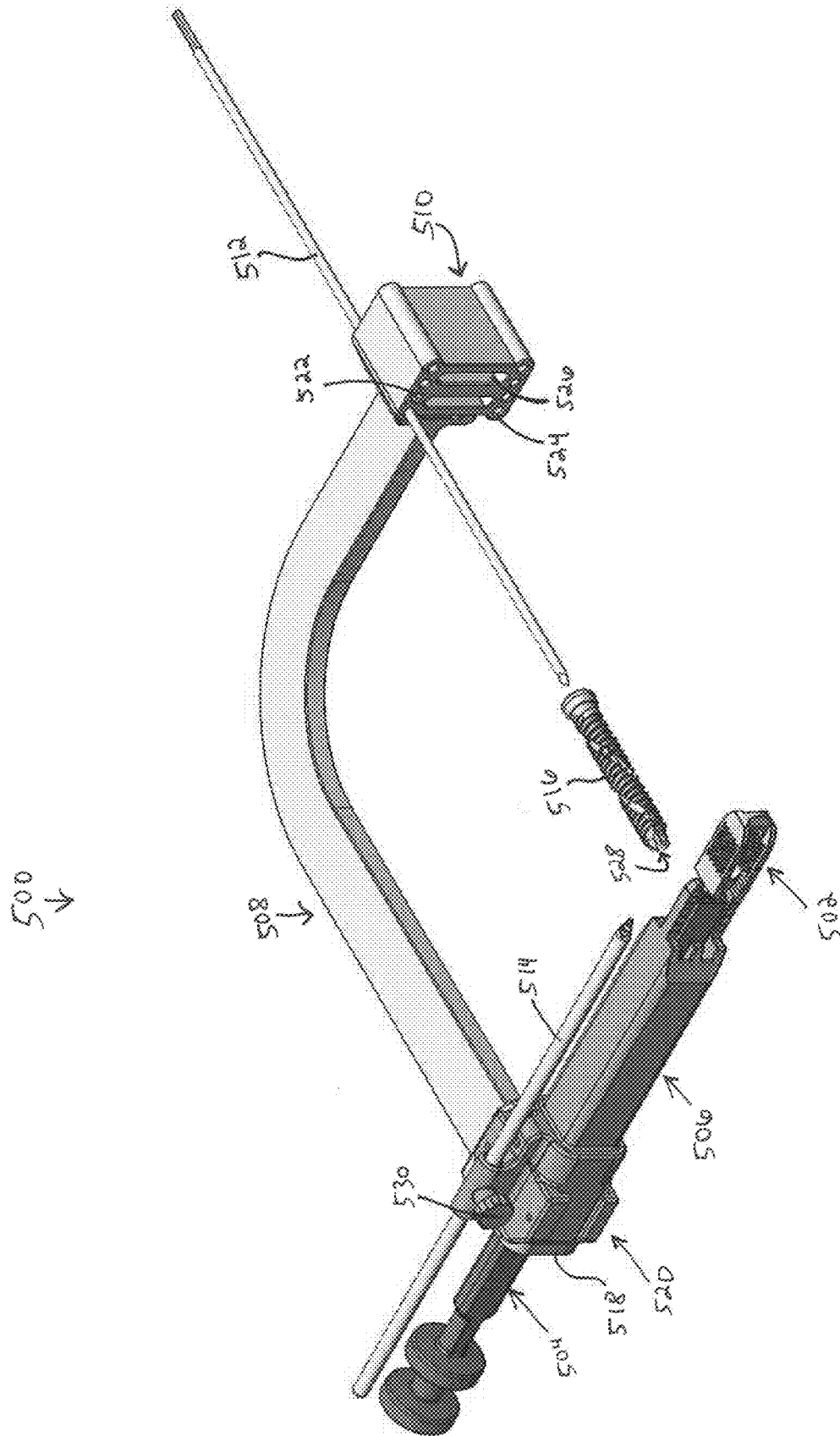

FIG. 23

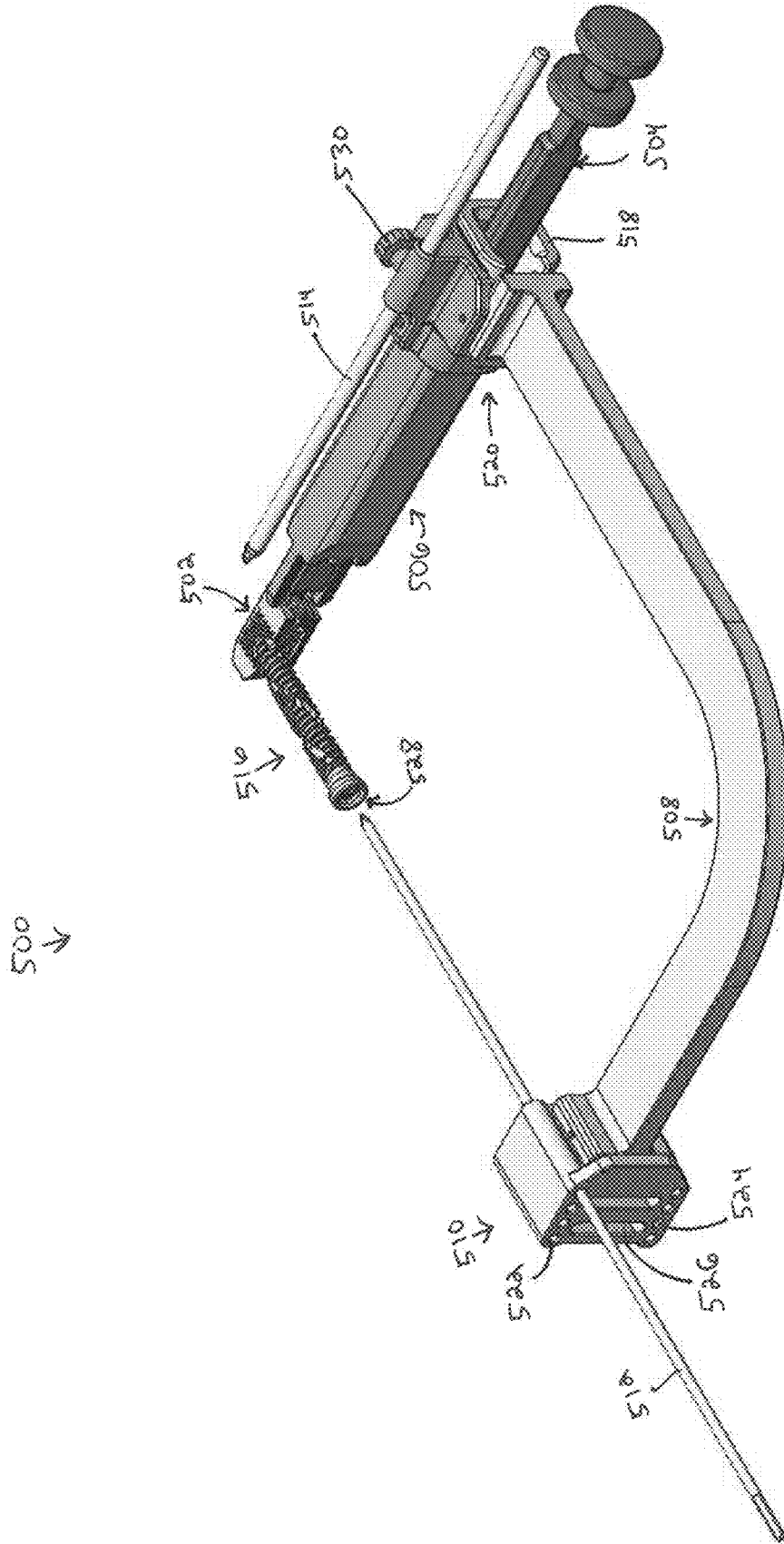
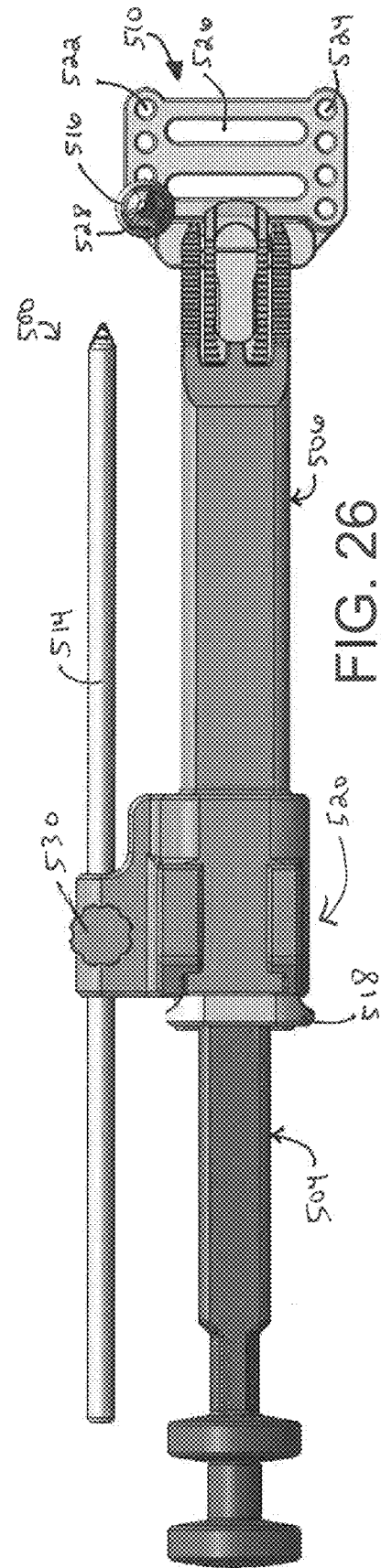
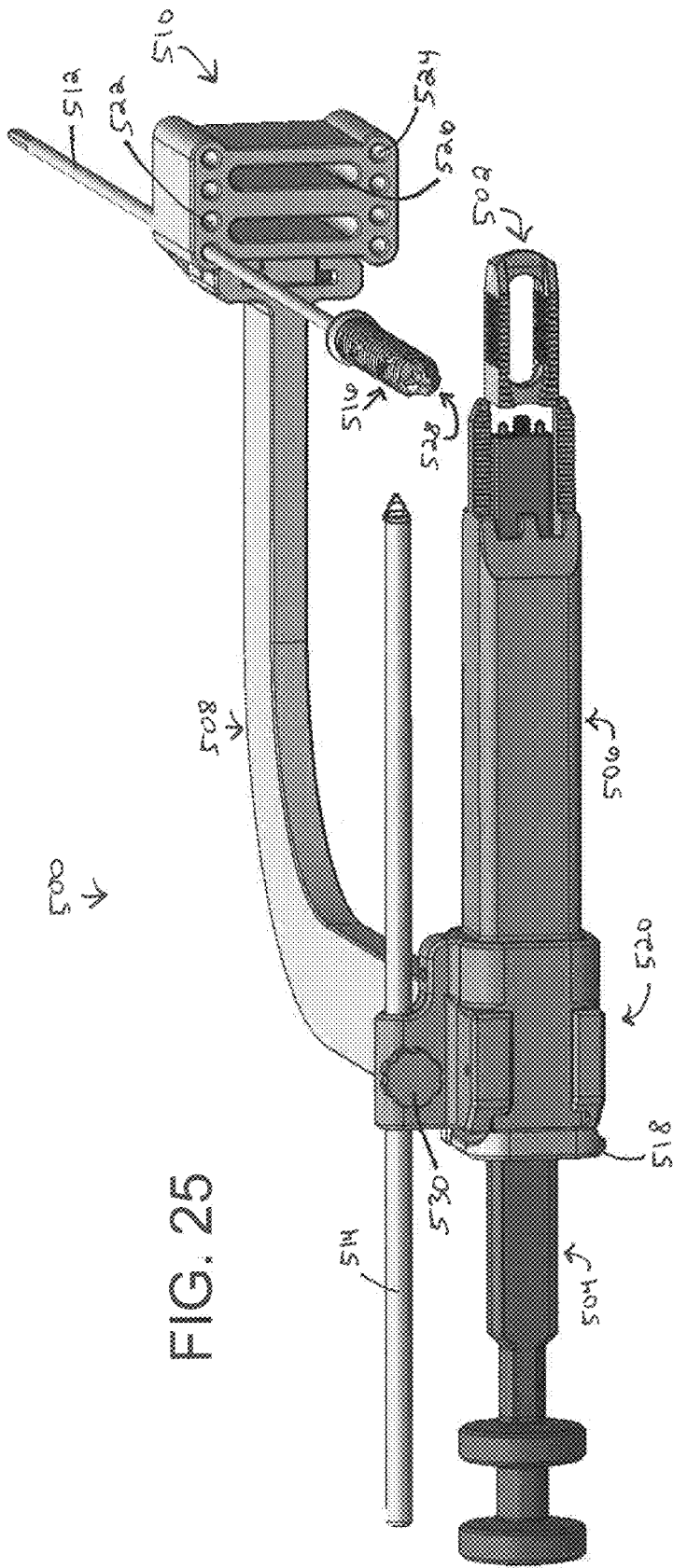
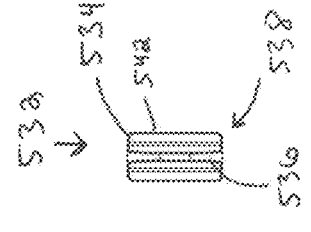
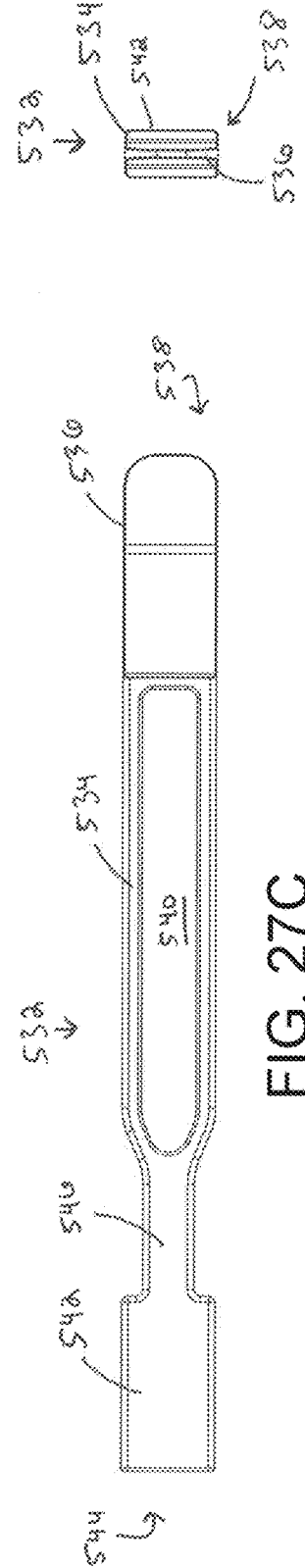
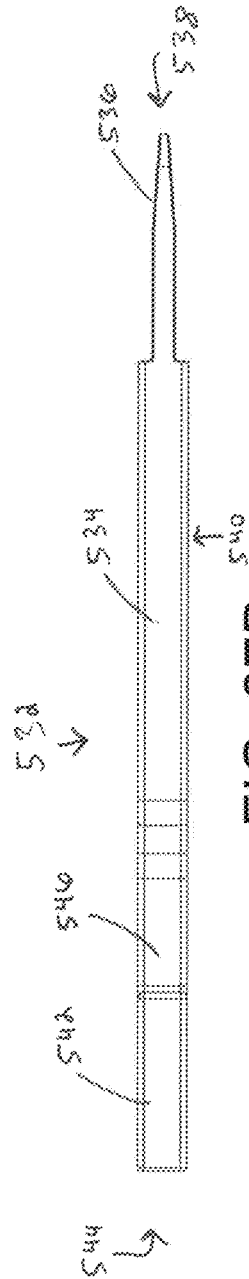
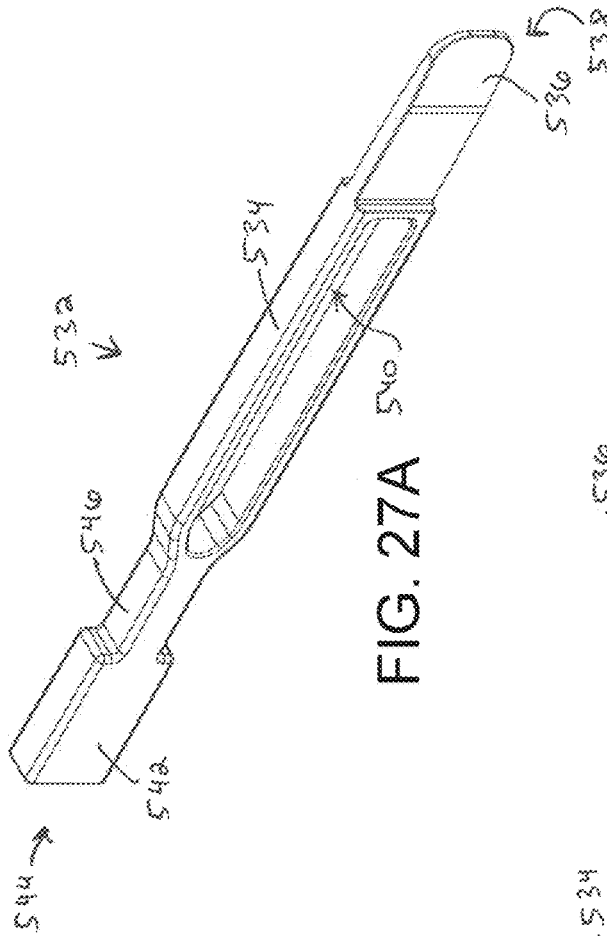
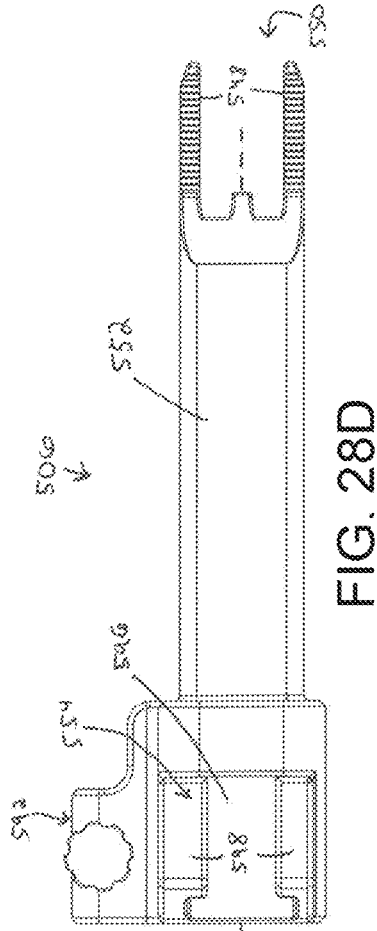
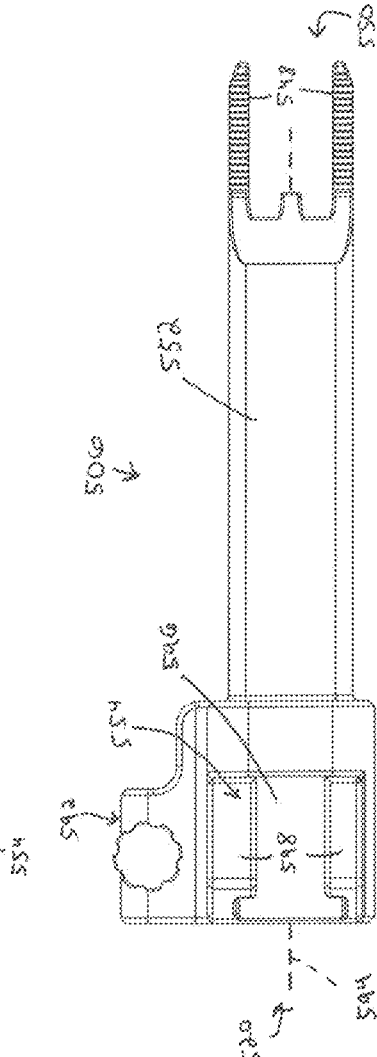
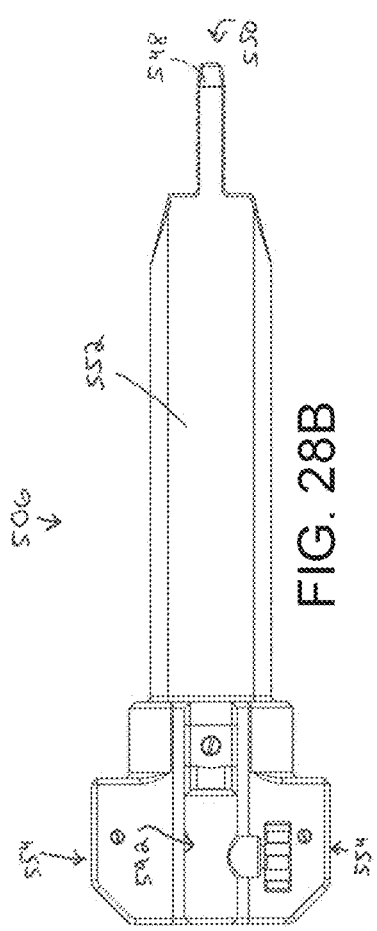
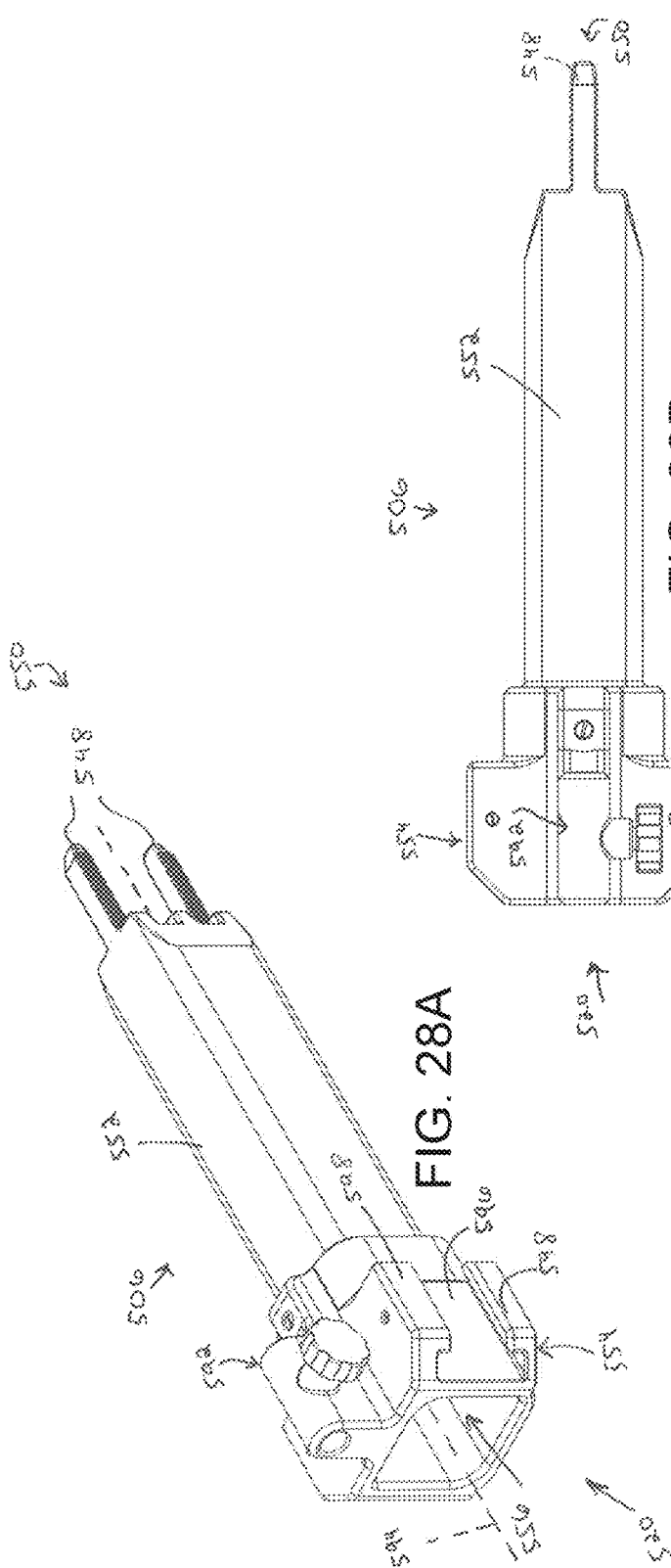

FIG. 24









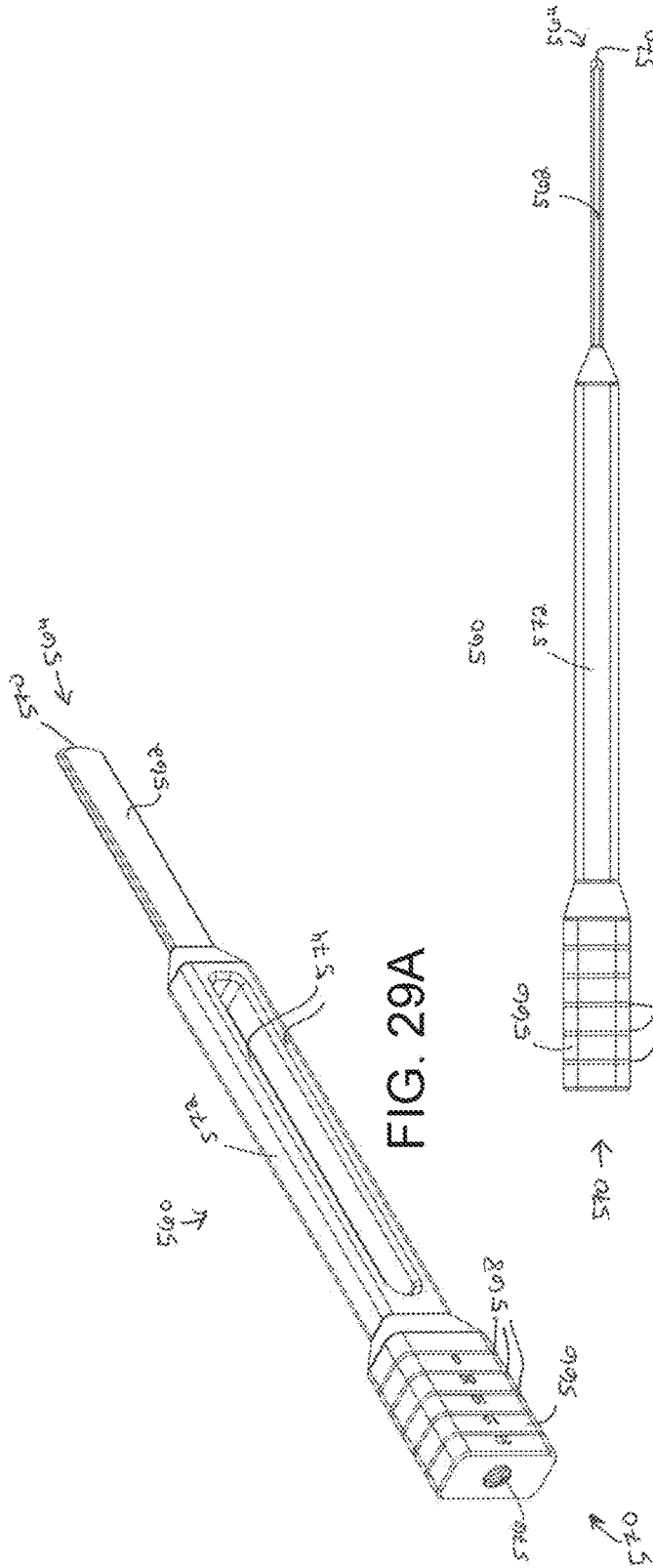

FIG. 29A

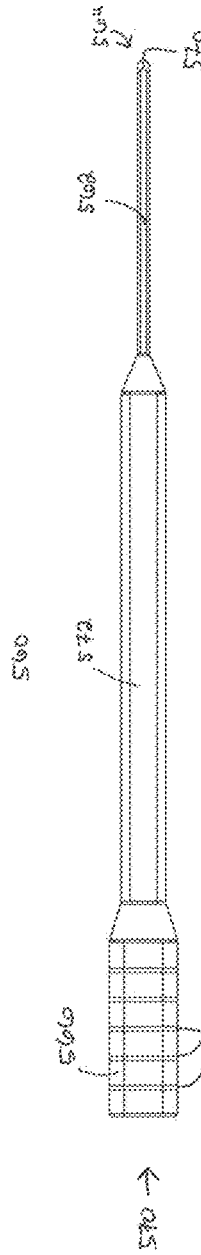

FIG. 29B

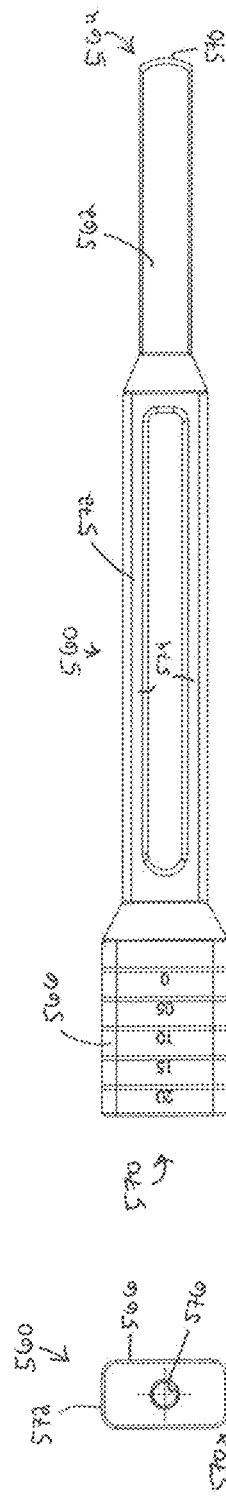

FIG. 29C

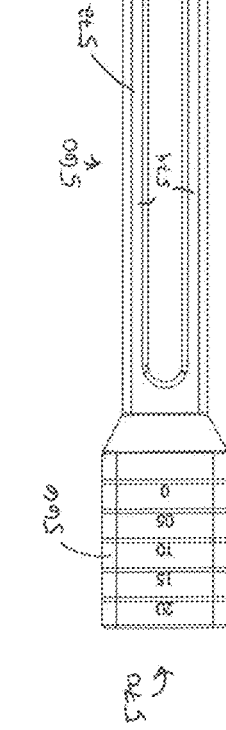

FIG. 29D

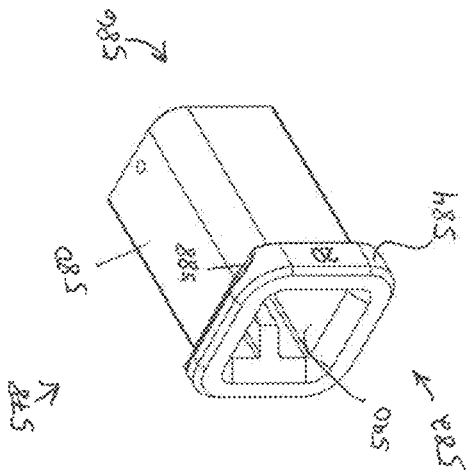

FIG. 30A

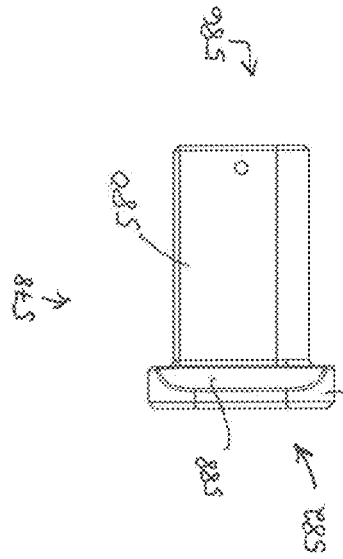

FIG. 30B

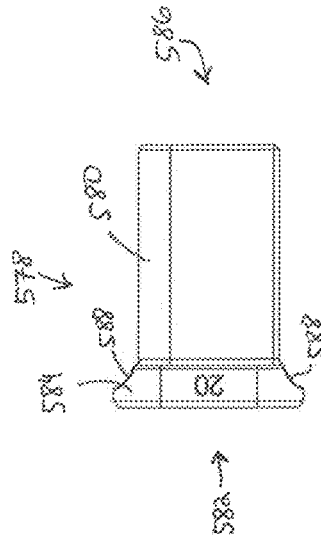

FIG. 30D

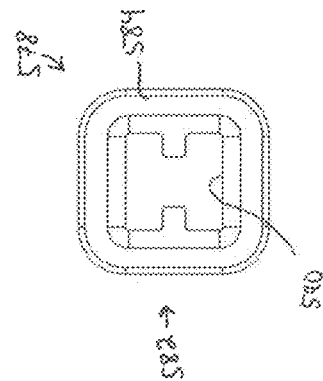

FIG. 30C

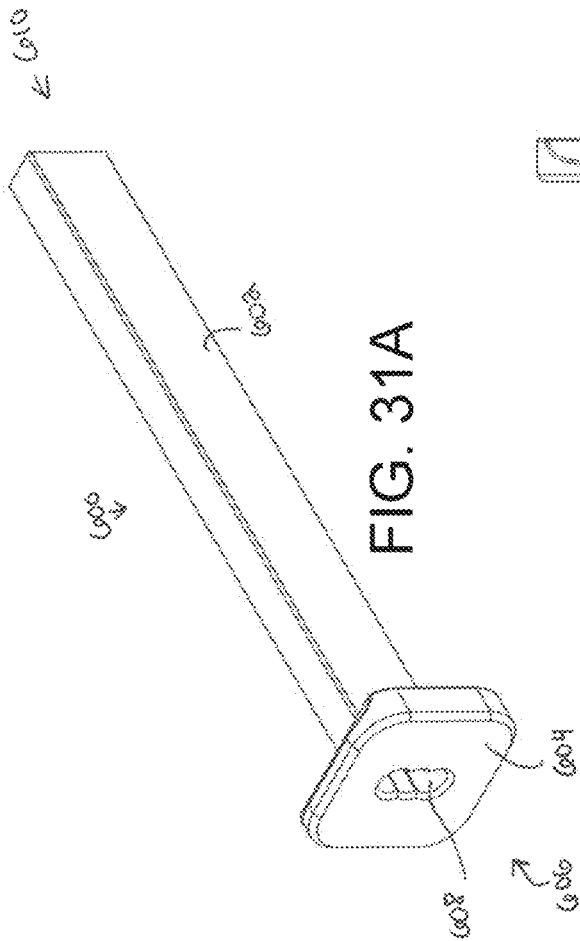

FIG. 31A

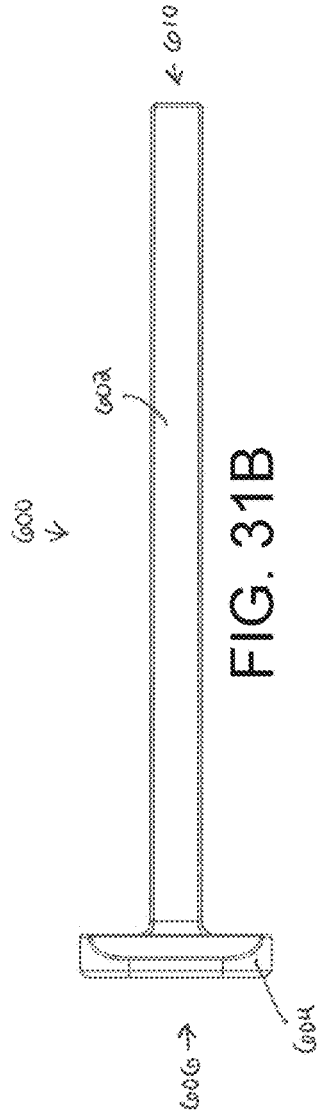

FIG. 31B

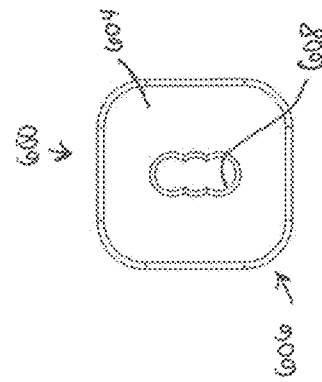

FIG. 31C

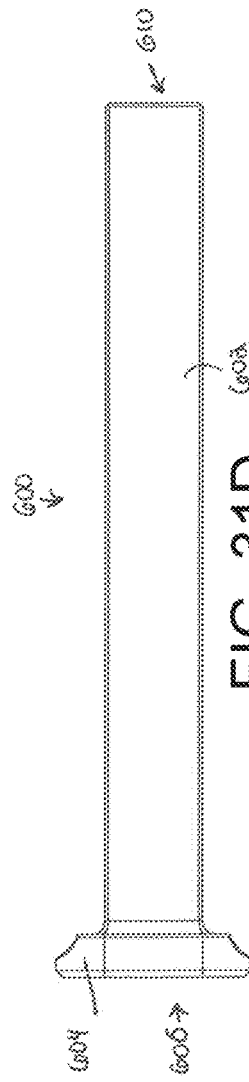

FIG. 31D

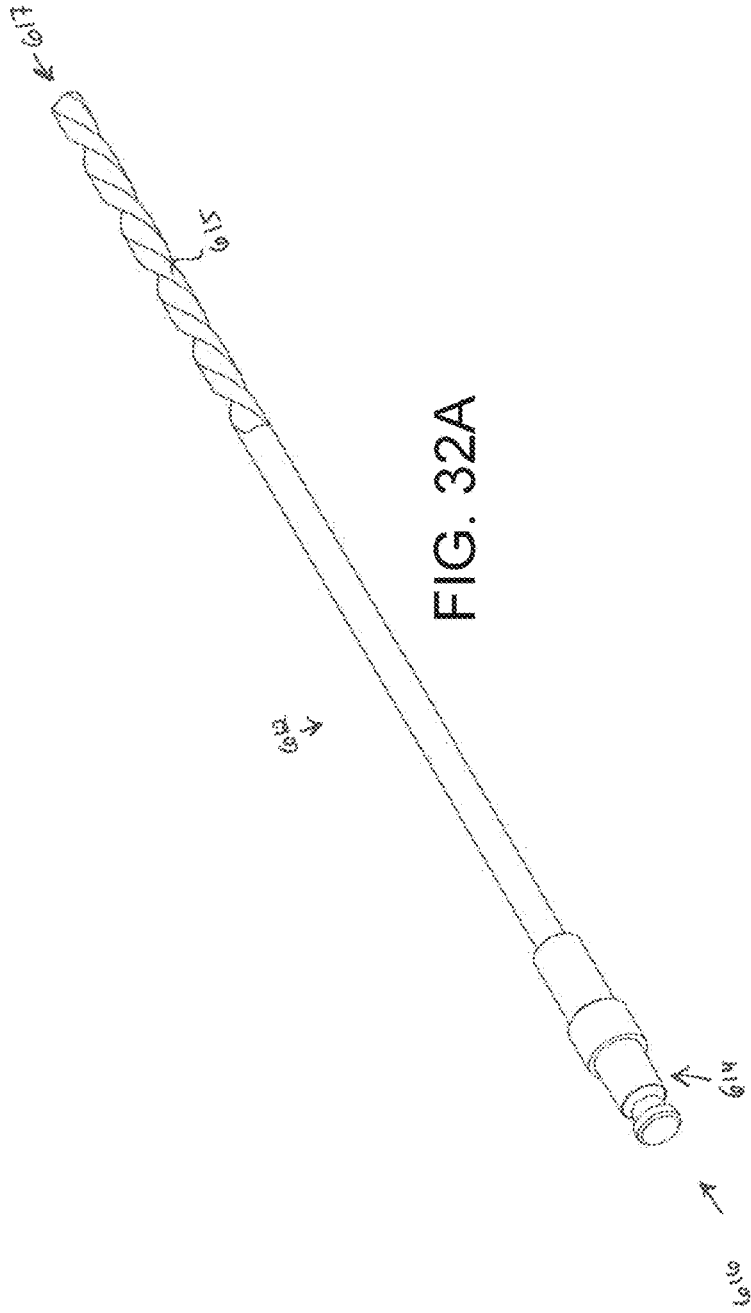

FIG. 32A

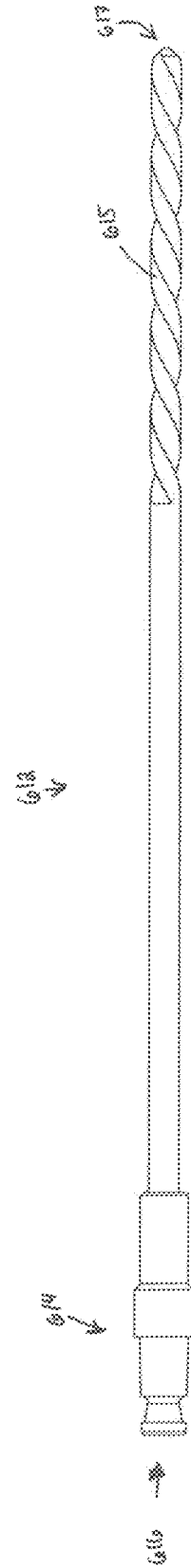

FIG. 32B

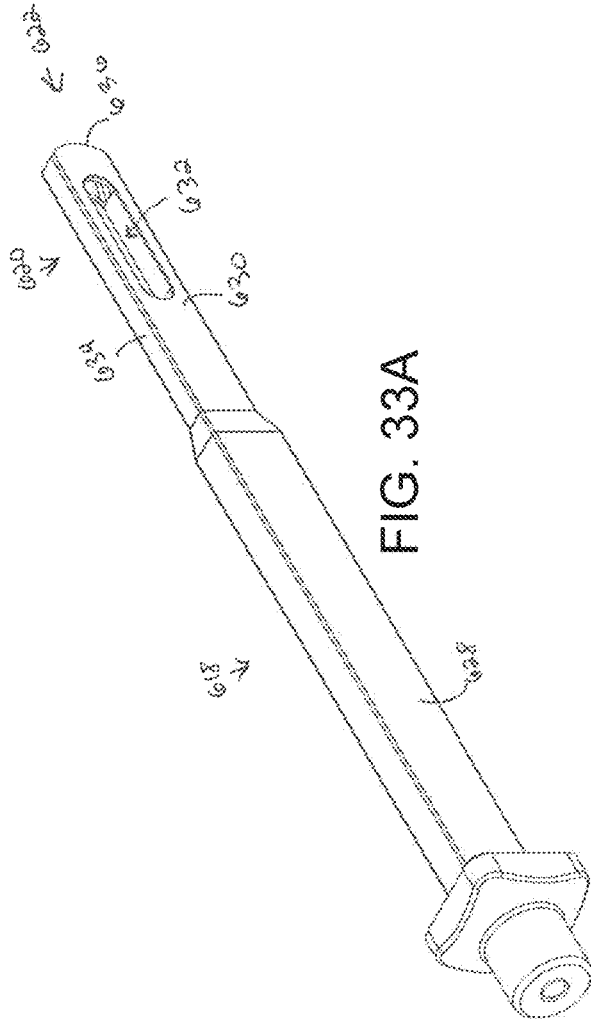

FIG. 33A

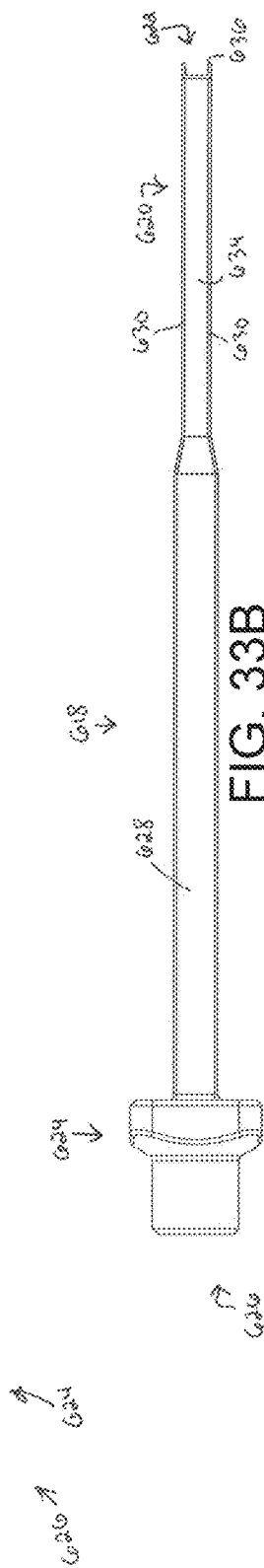

FIG. 33B

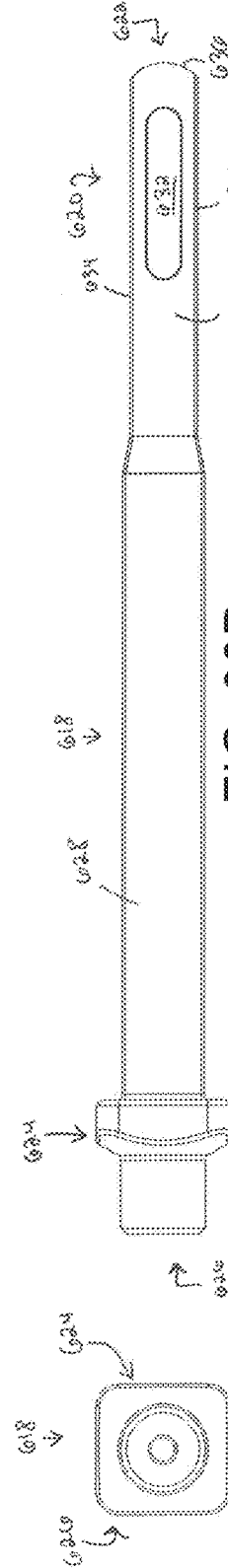

FIG. 33D

FIG. 33C

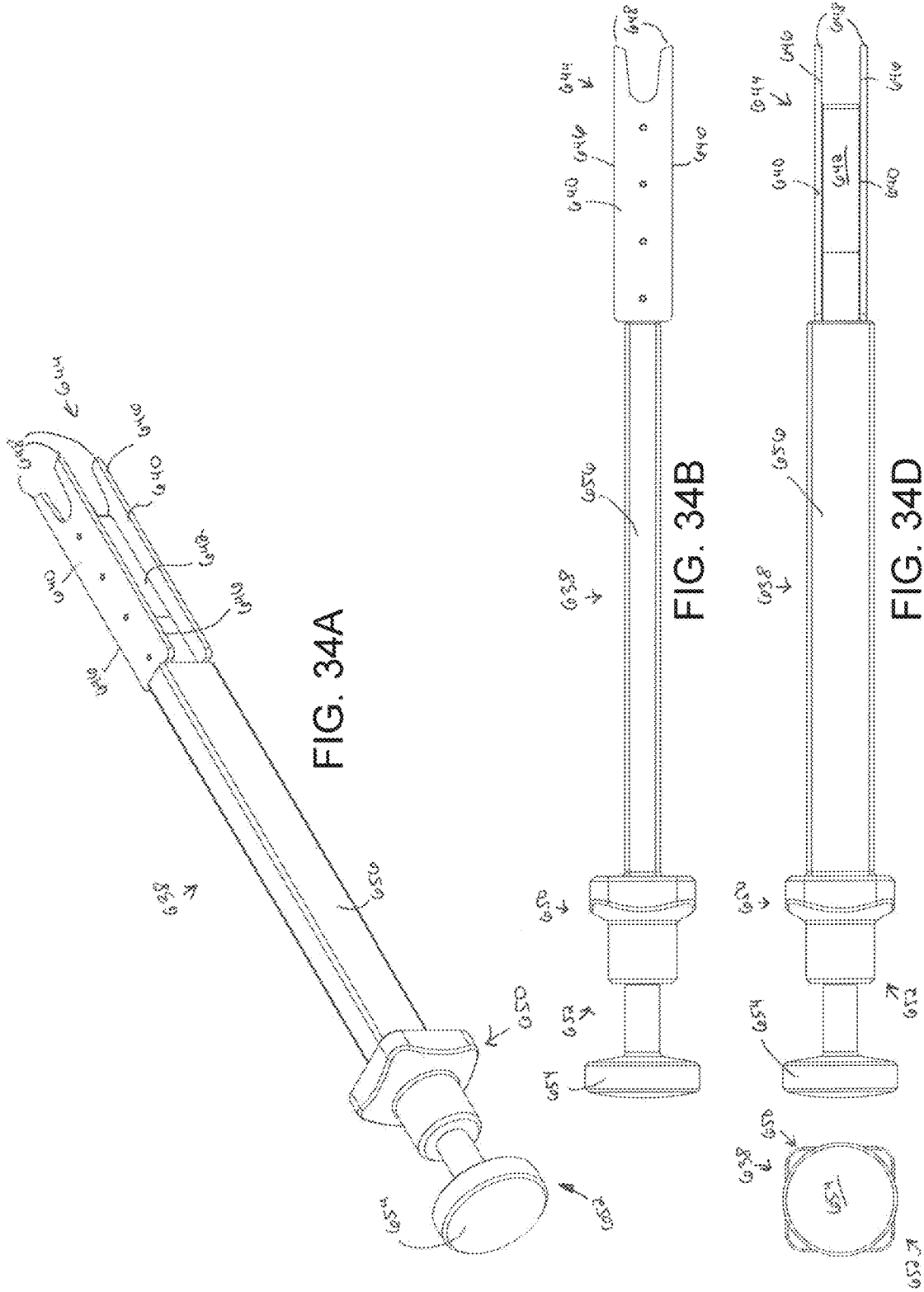

FIG. 34A

FIG. 34B

FIG. 34D

FIG. 34C

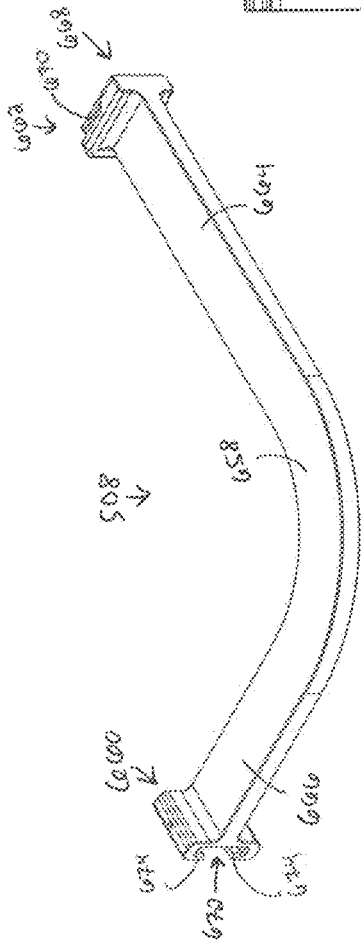

FIG. 35A

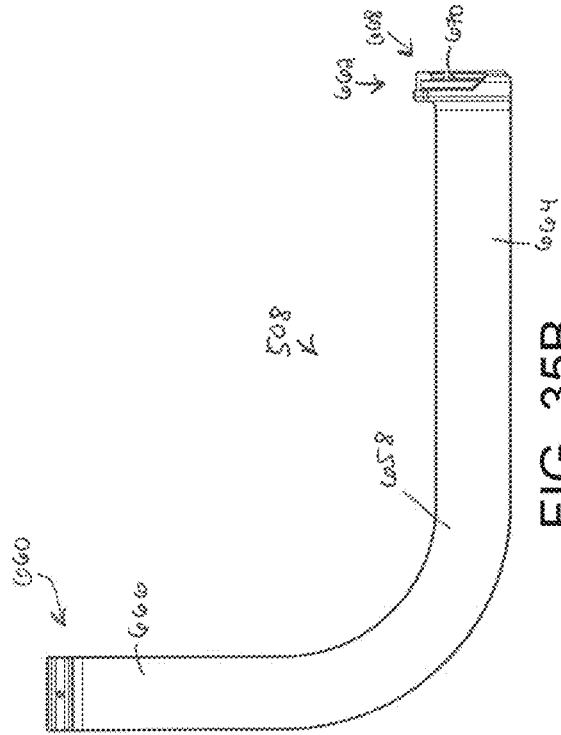

FIG. 35B

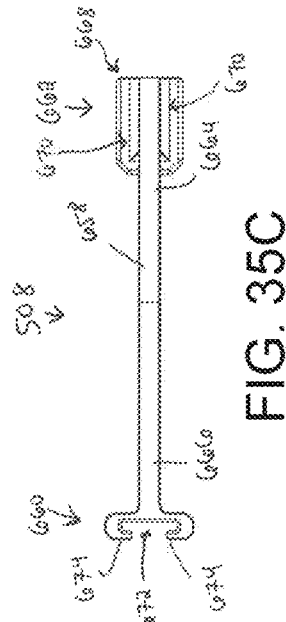

FIG. 35C

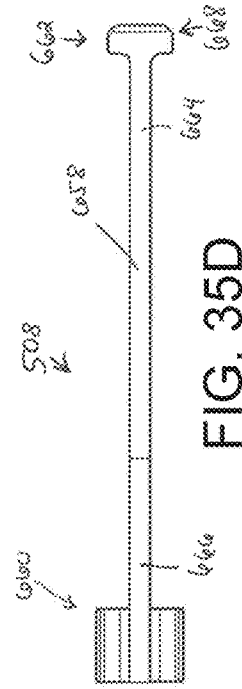

FIG. 35D



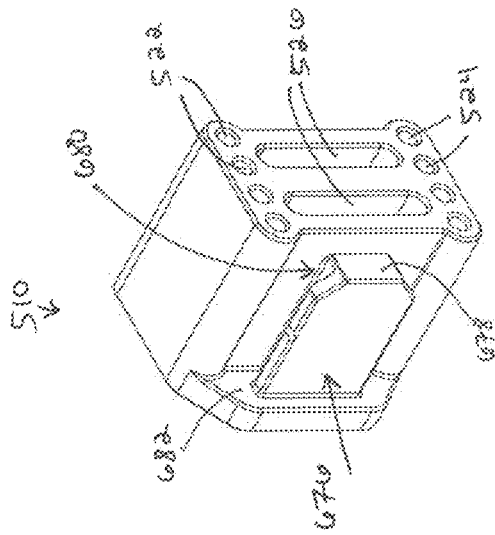

FIG. 36A

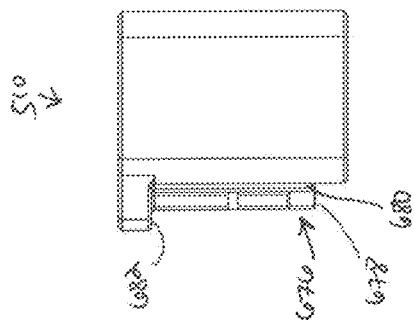

FIG. 36B

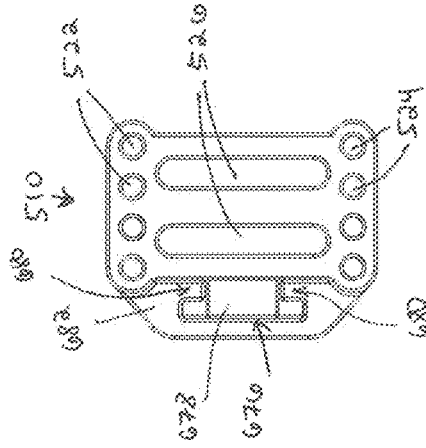

FIG. 36D

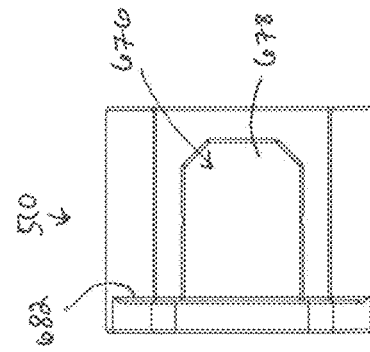

FIG. 36C



FIG. 37A

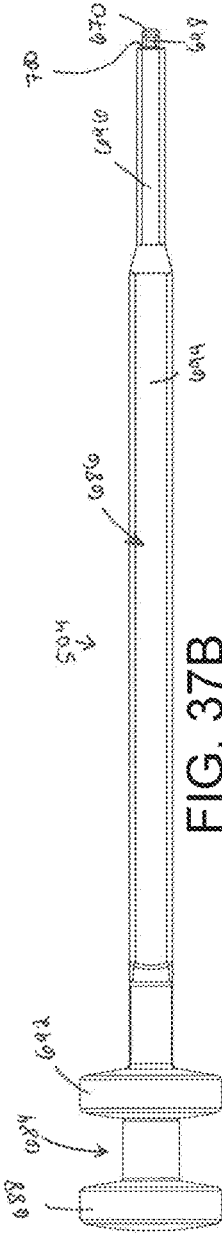

FIG. 37B

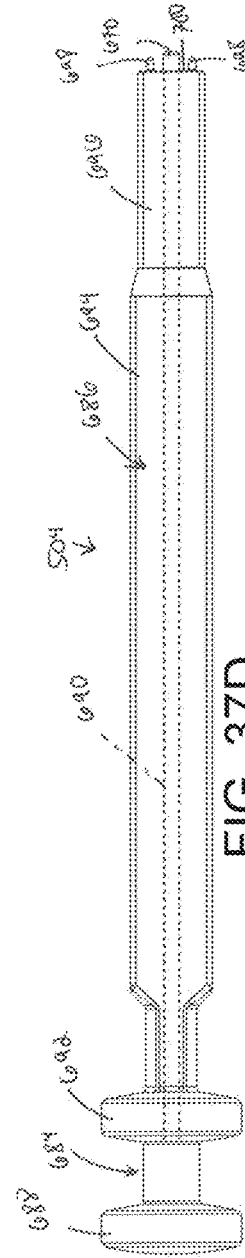

FIG. 37D

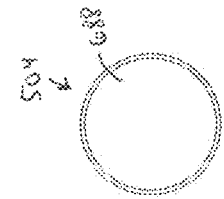

FIG. 37C

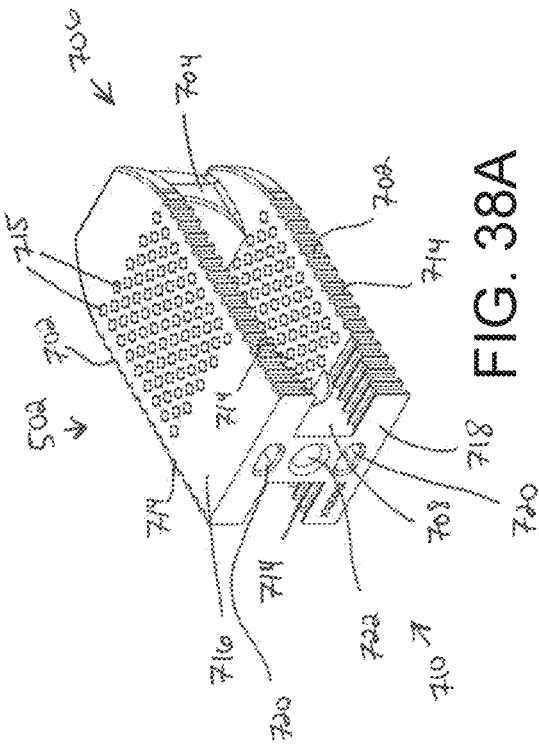

FIG. 38A

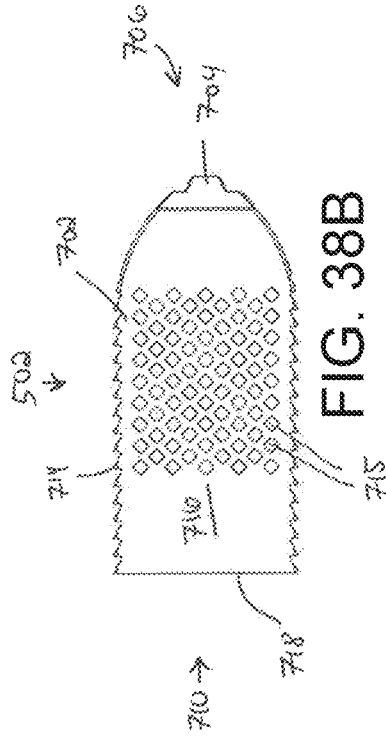

FIG. 38B

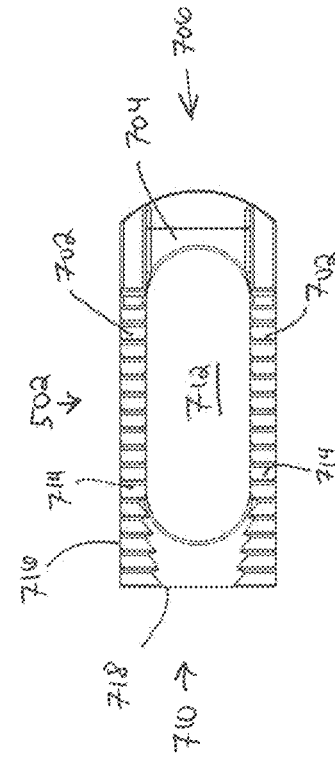

FIG. 38D

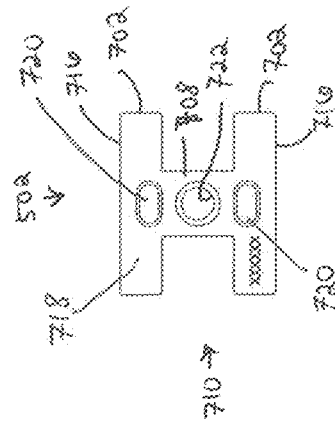

FIG. 38C

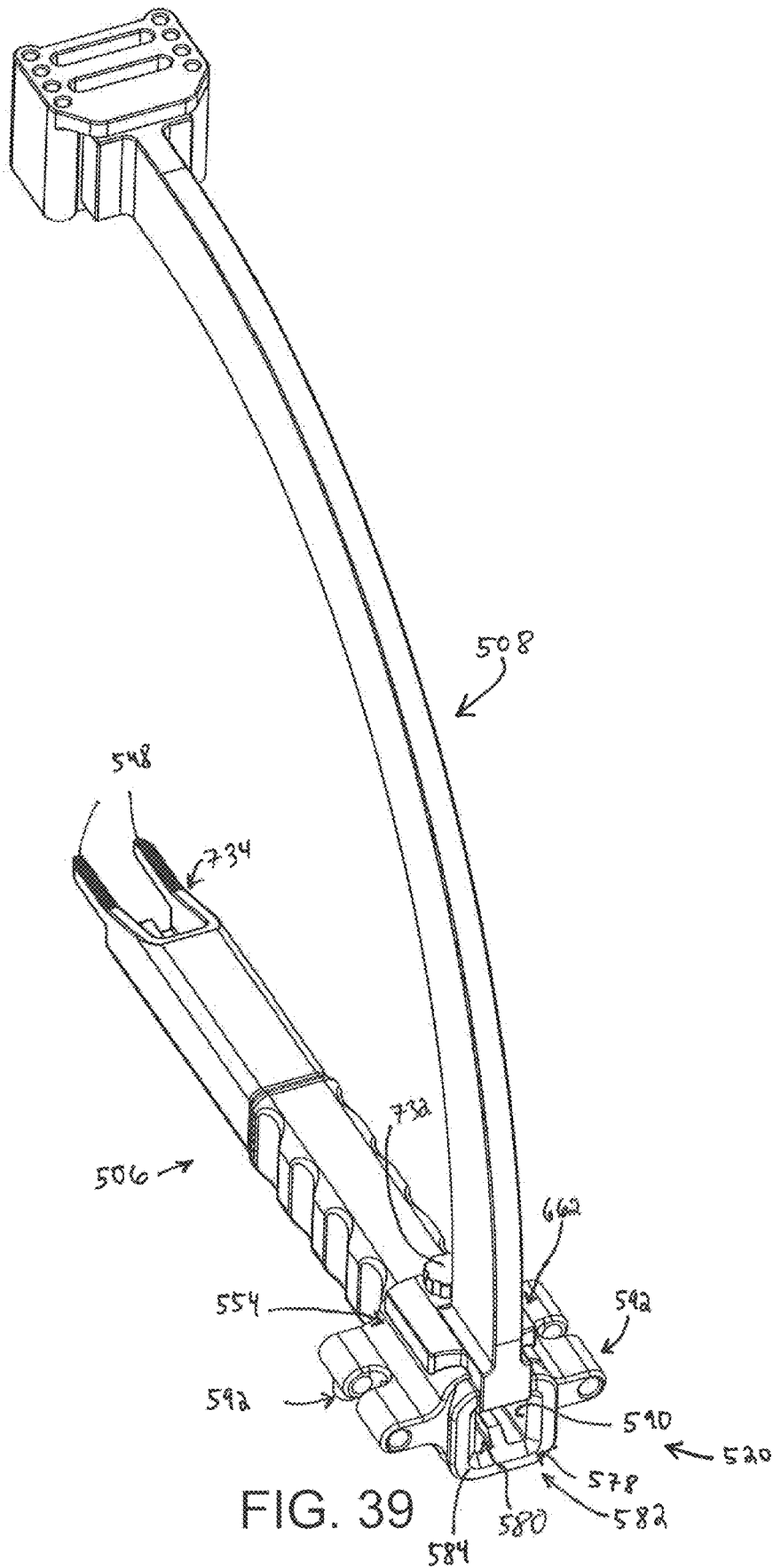

FIG. 39

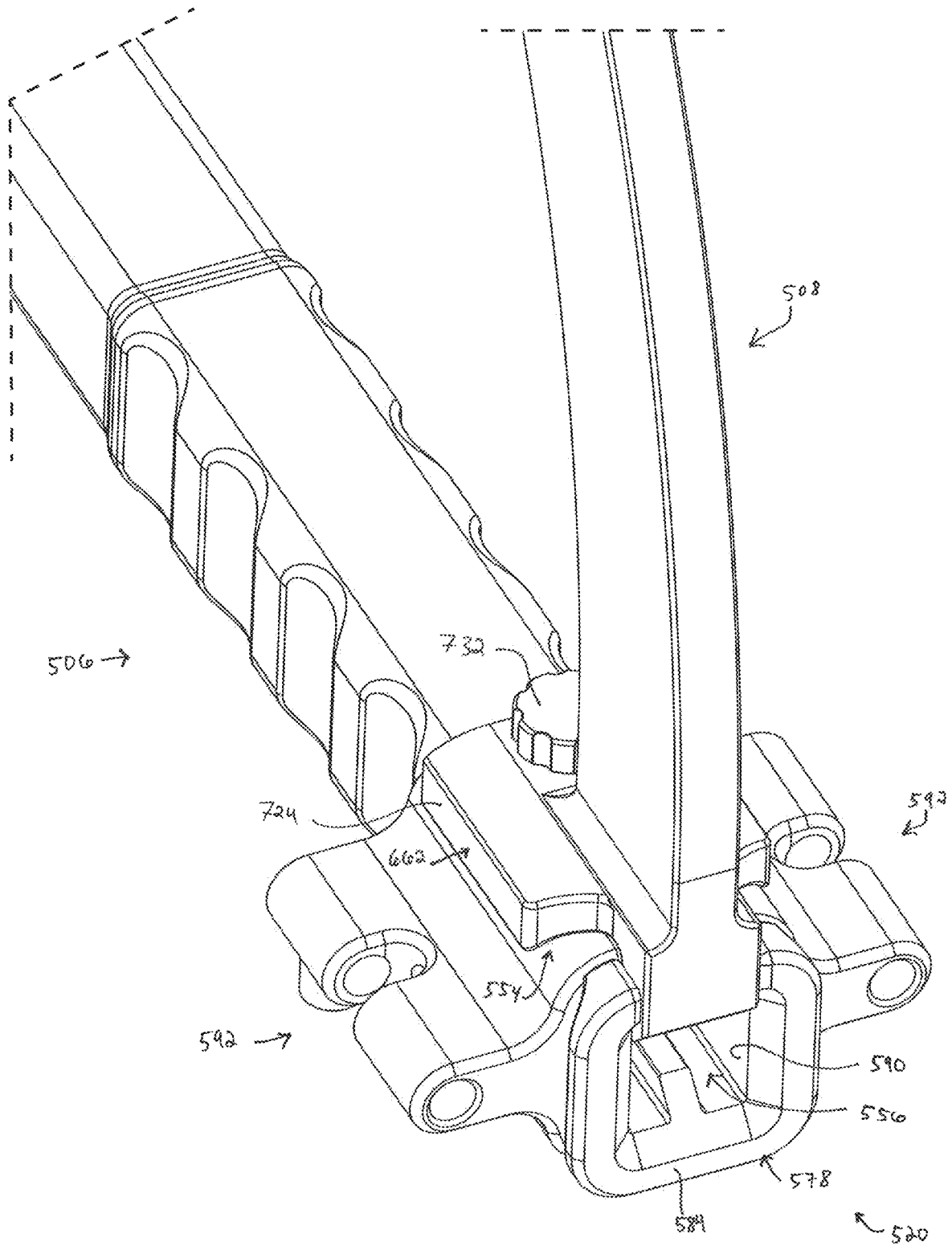

FIG. 40

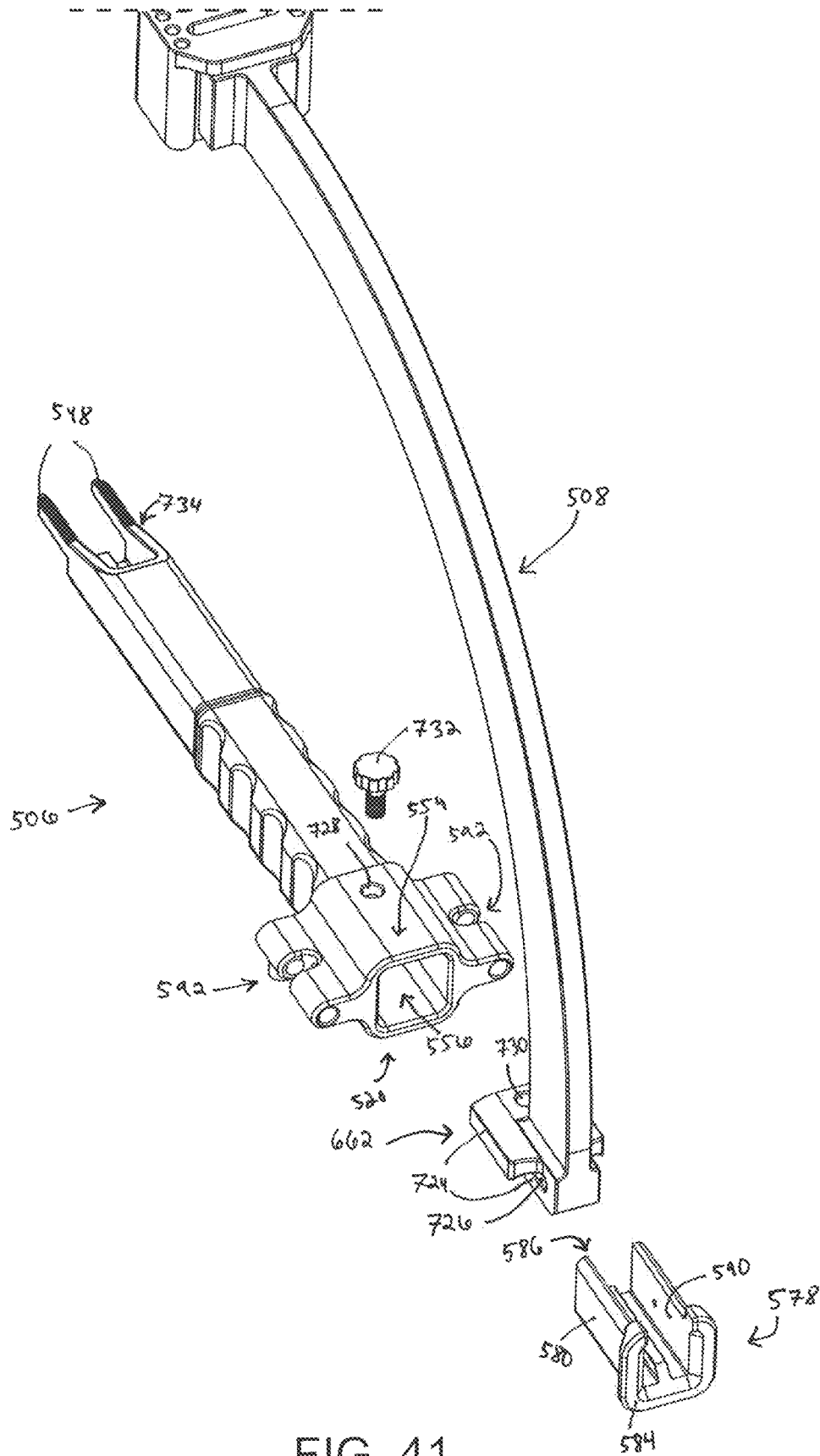

FIG. 41

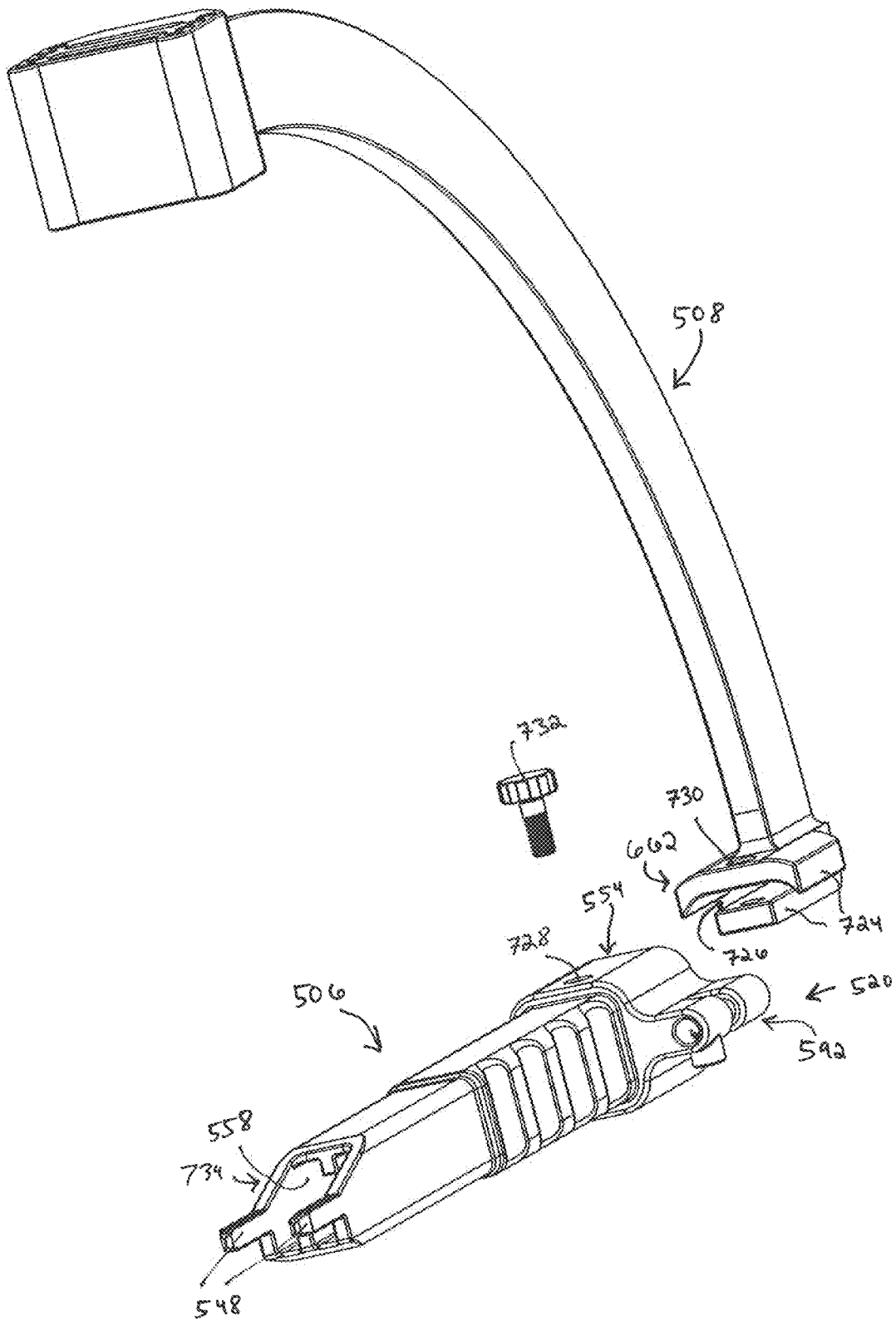

FIG. 42

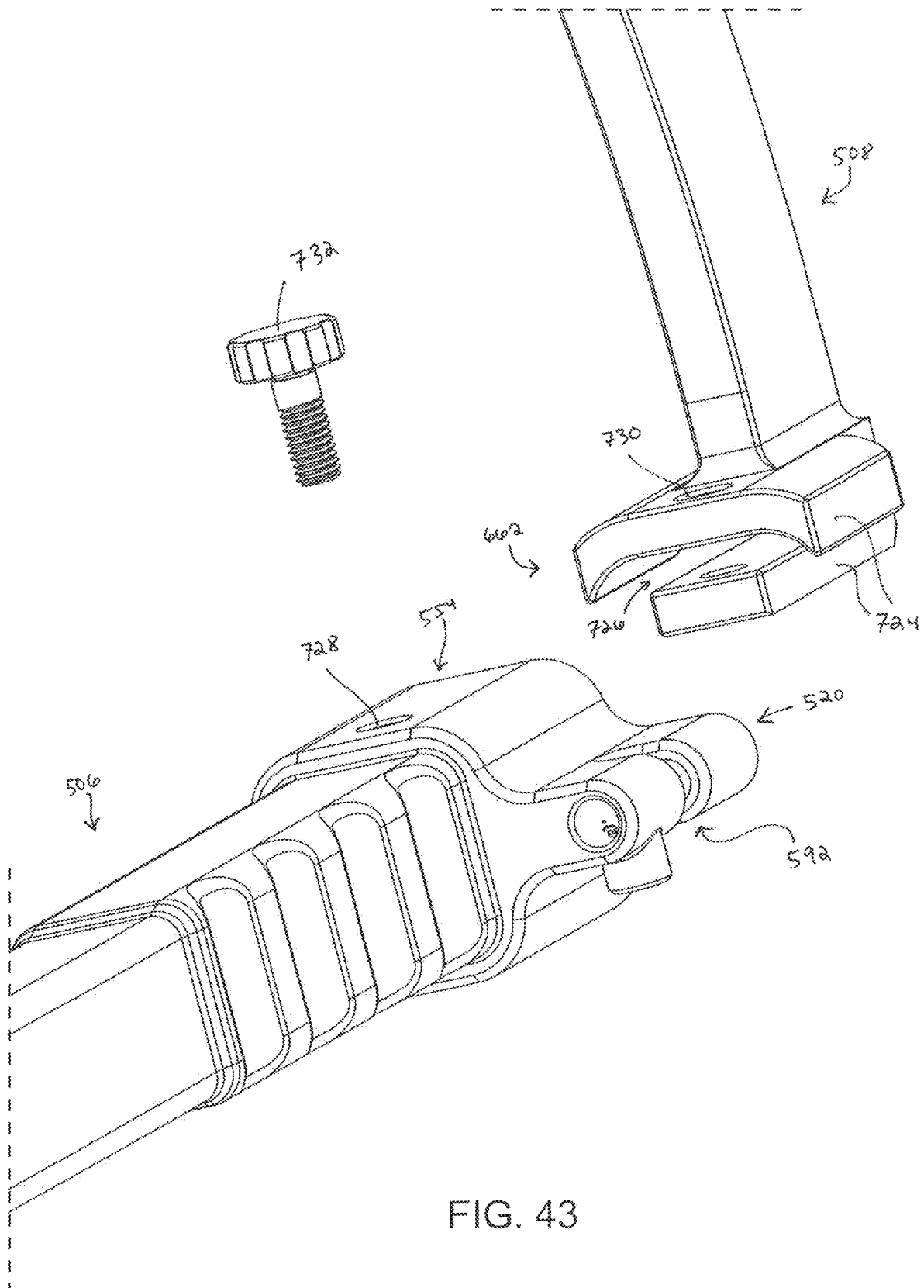

FIG. 43



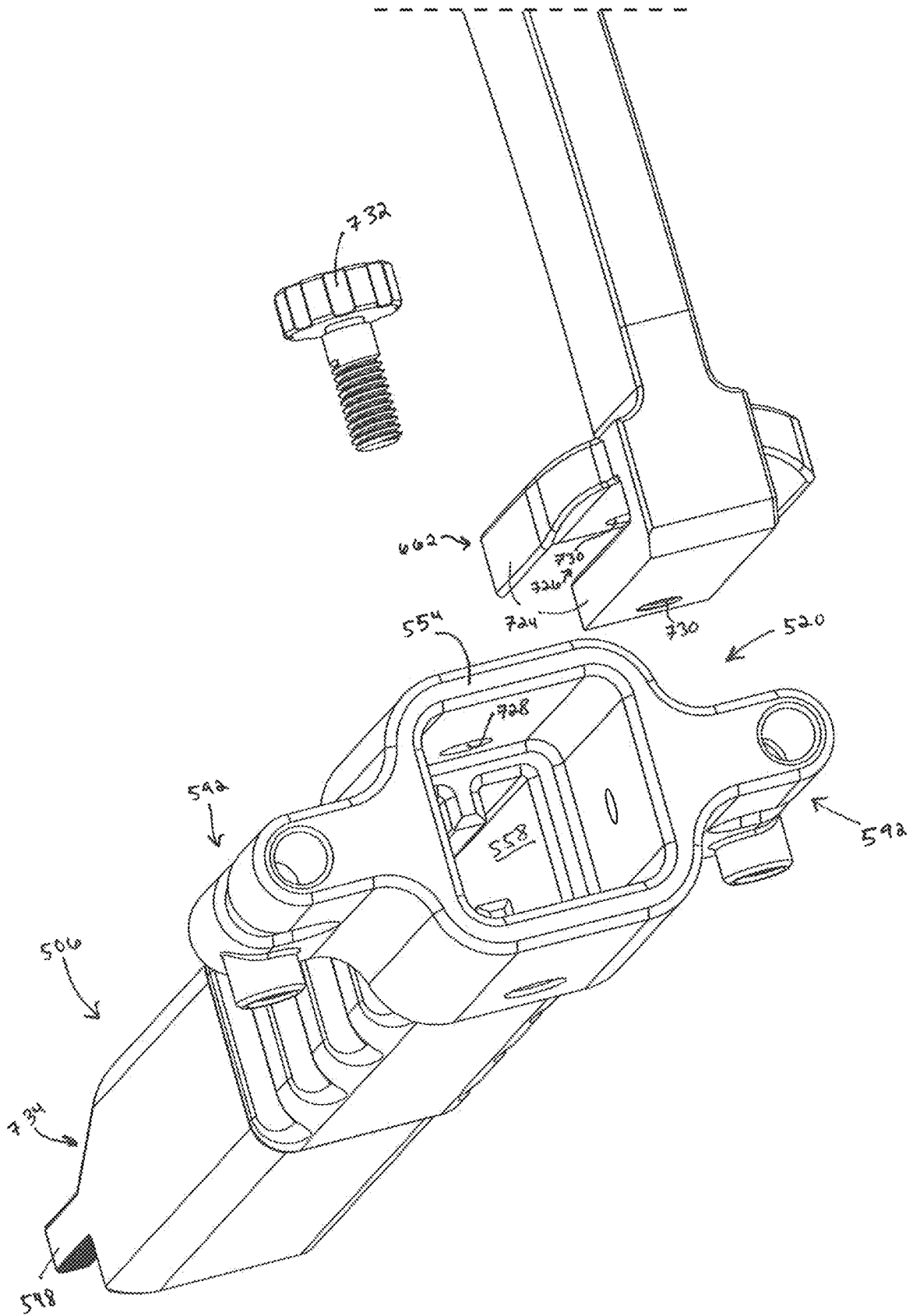

FIG. 44

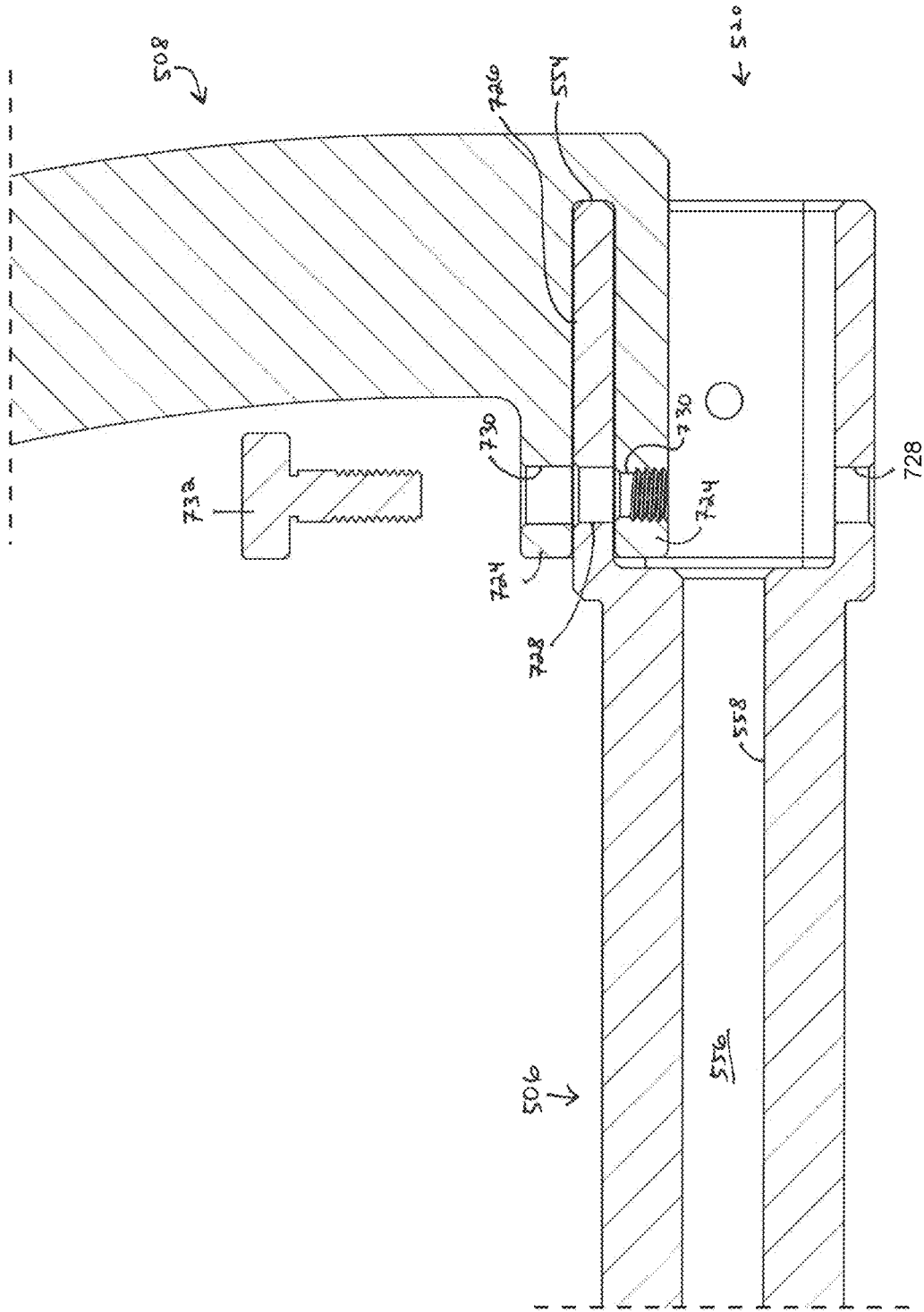

FIG. 45

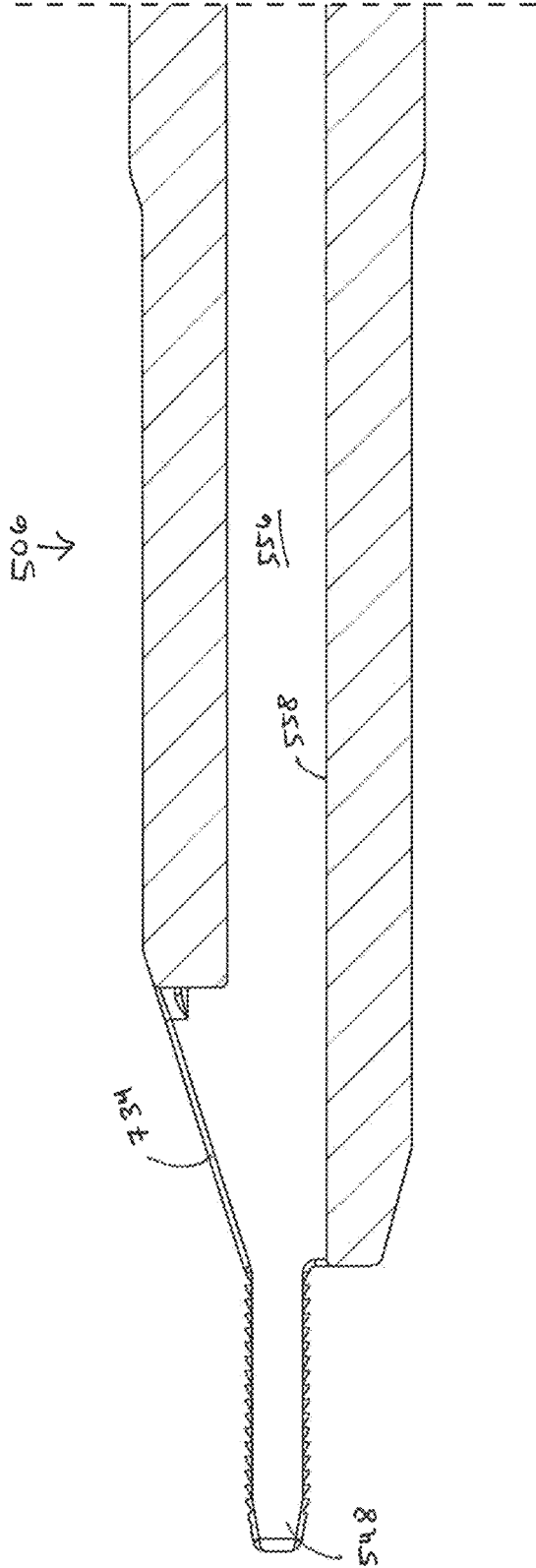

FIG. 46

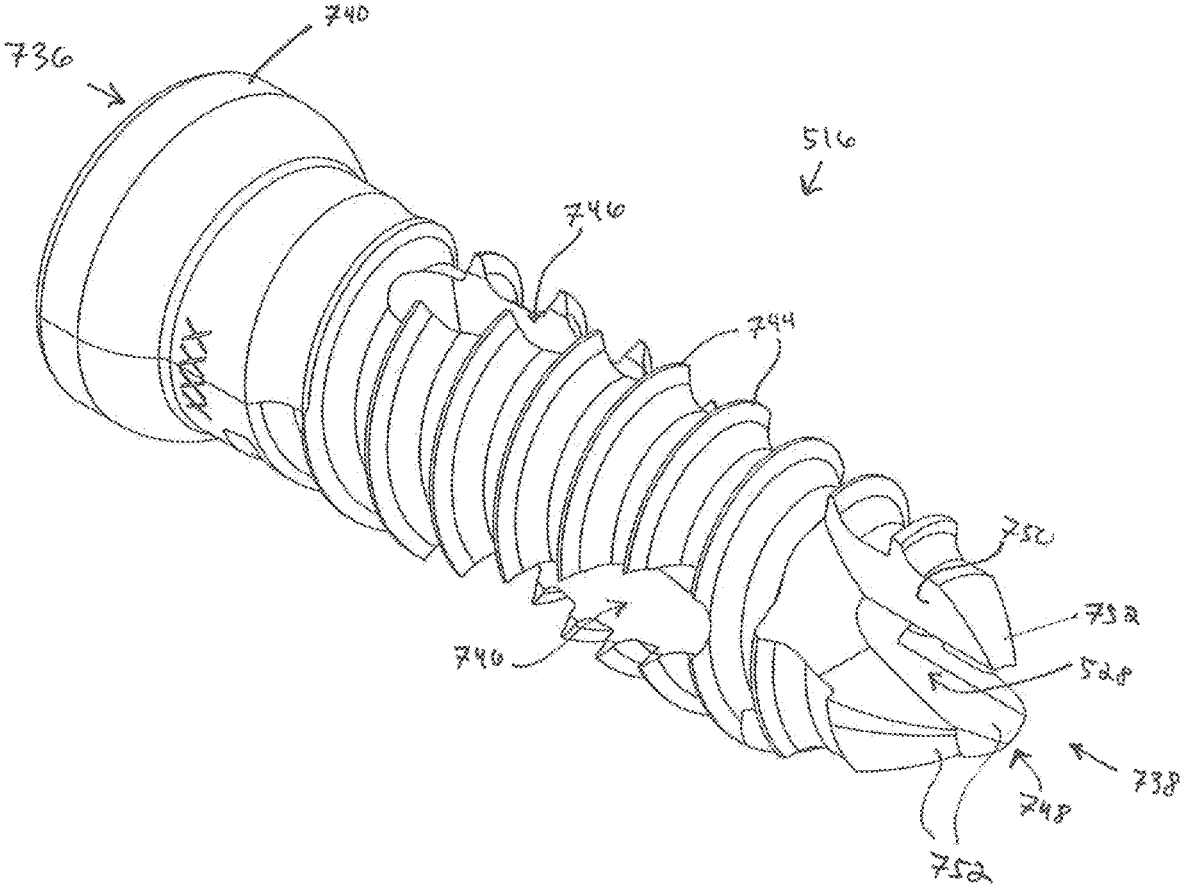
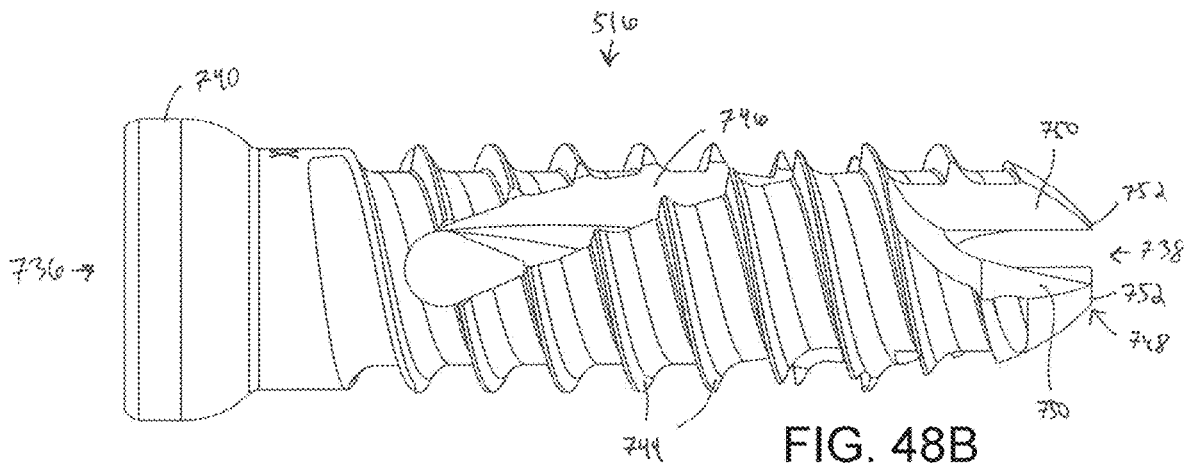
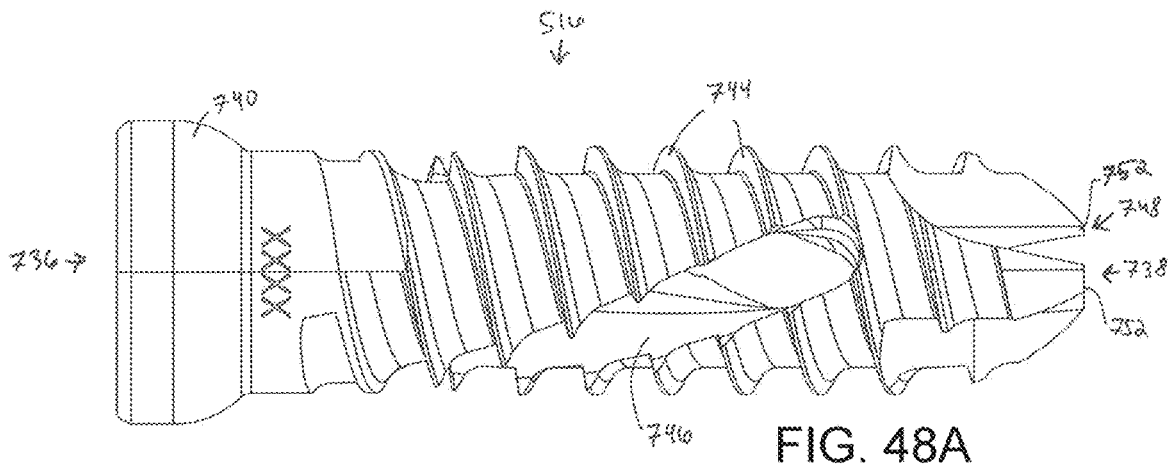

FIG. 47



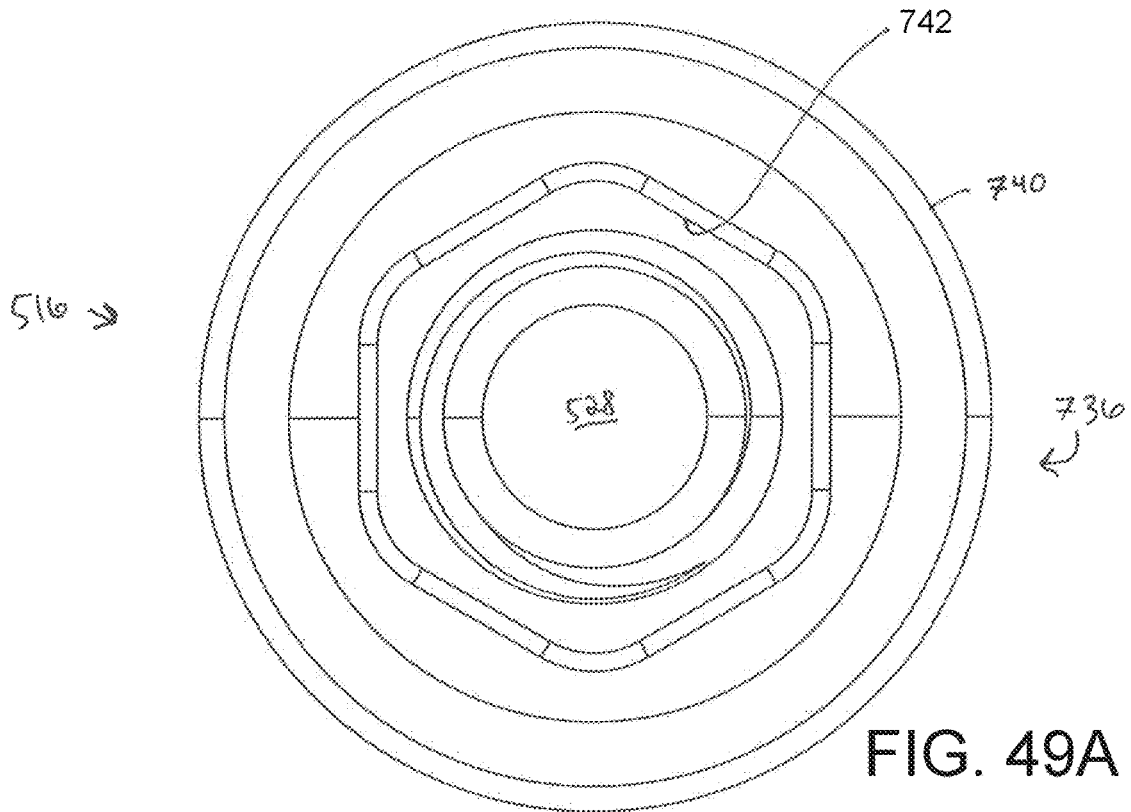

FIG. 49A

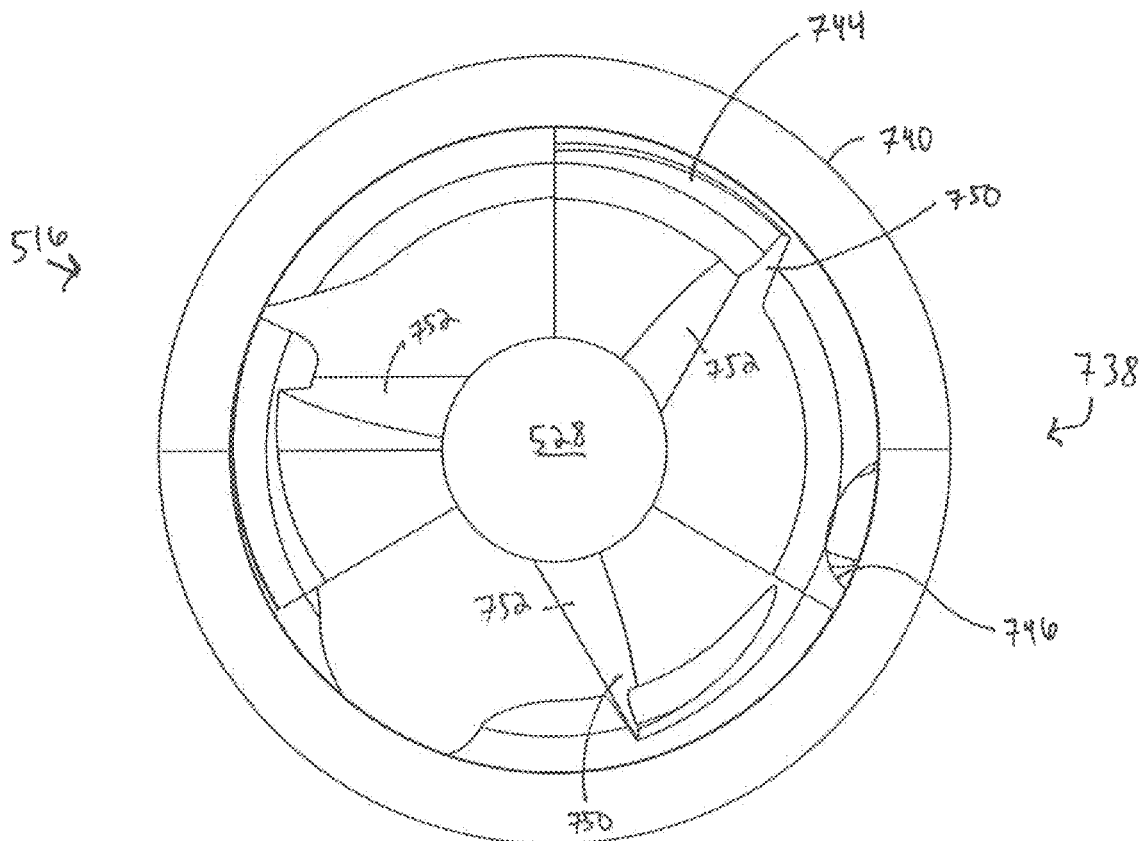

FIG. 49B

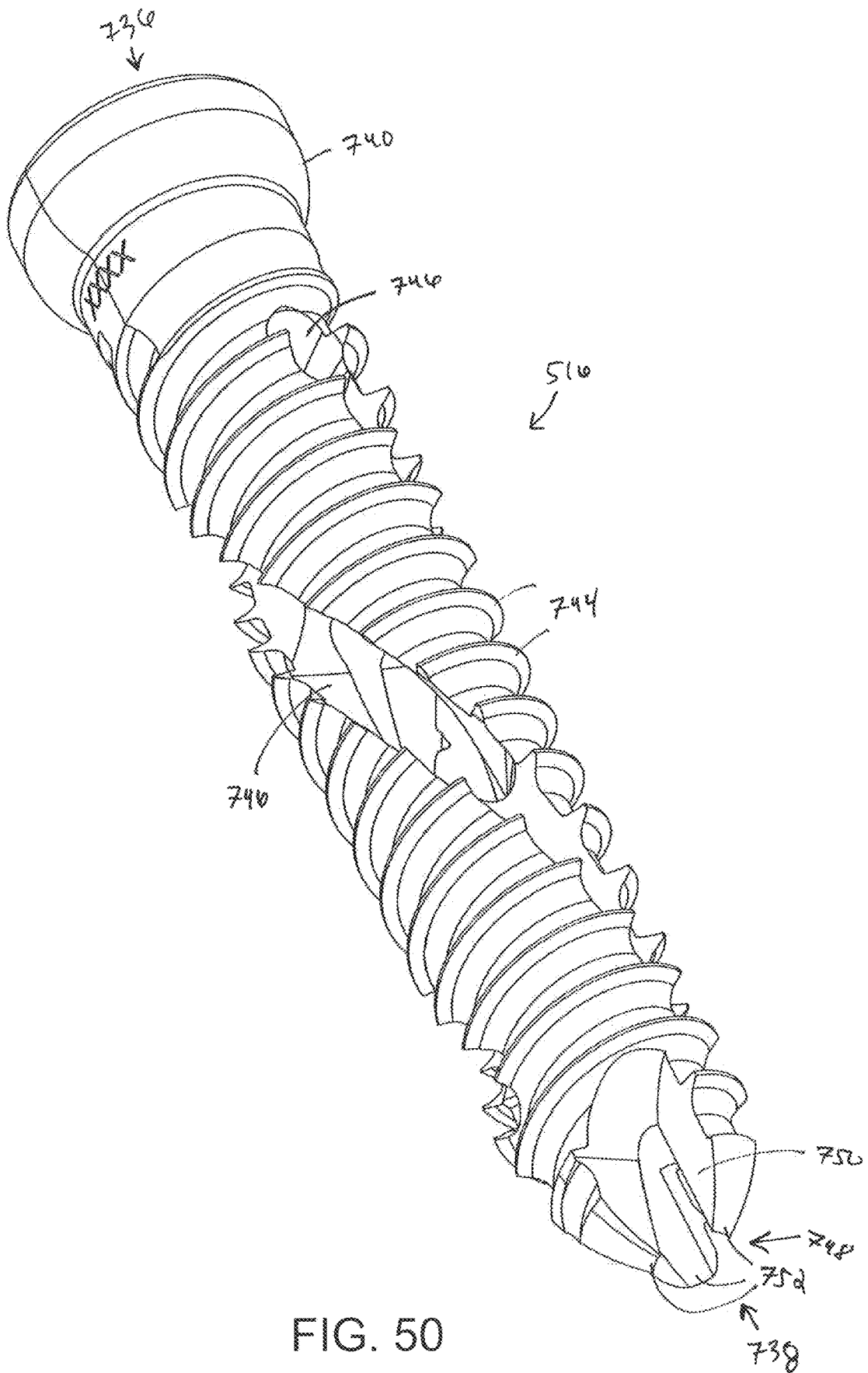
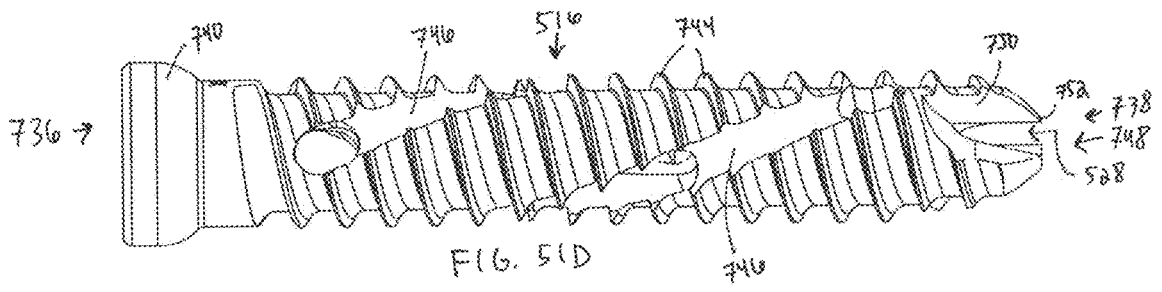
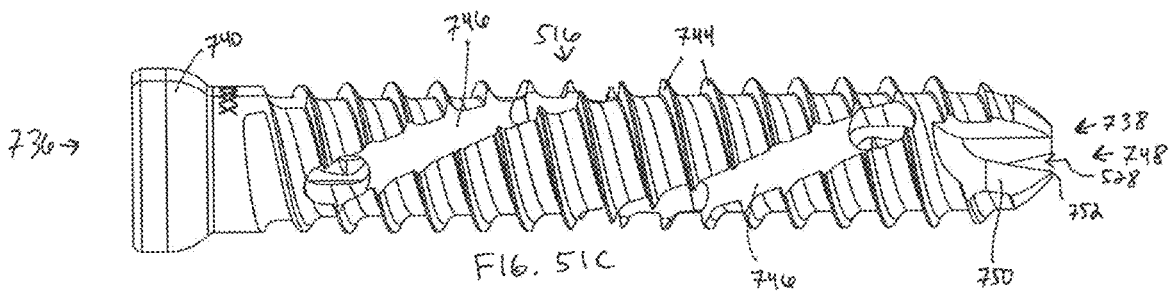
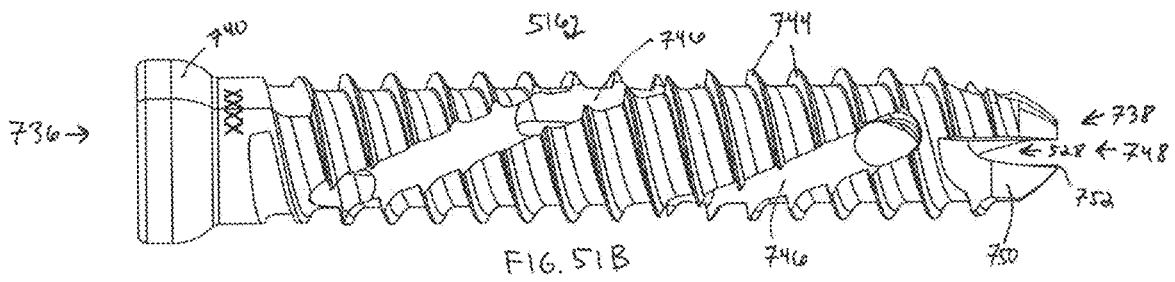
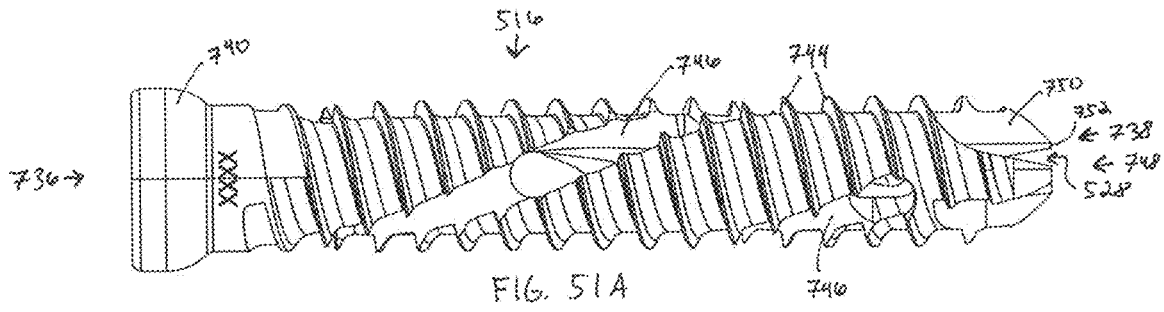
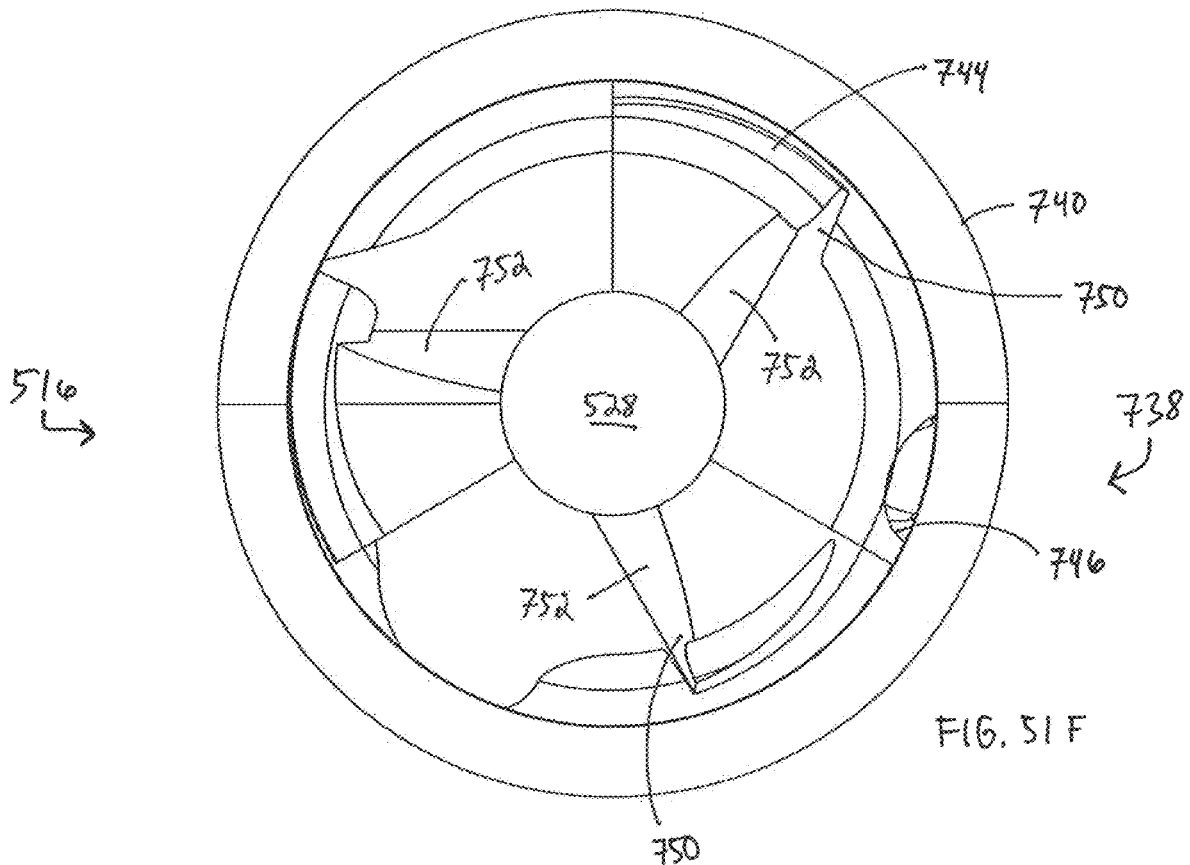
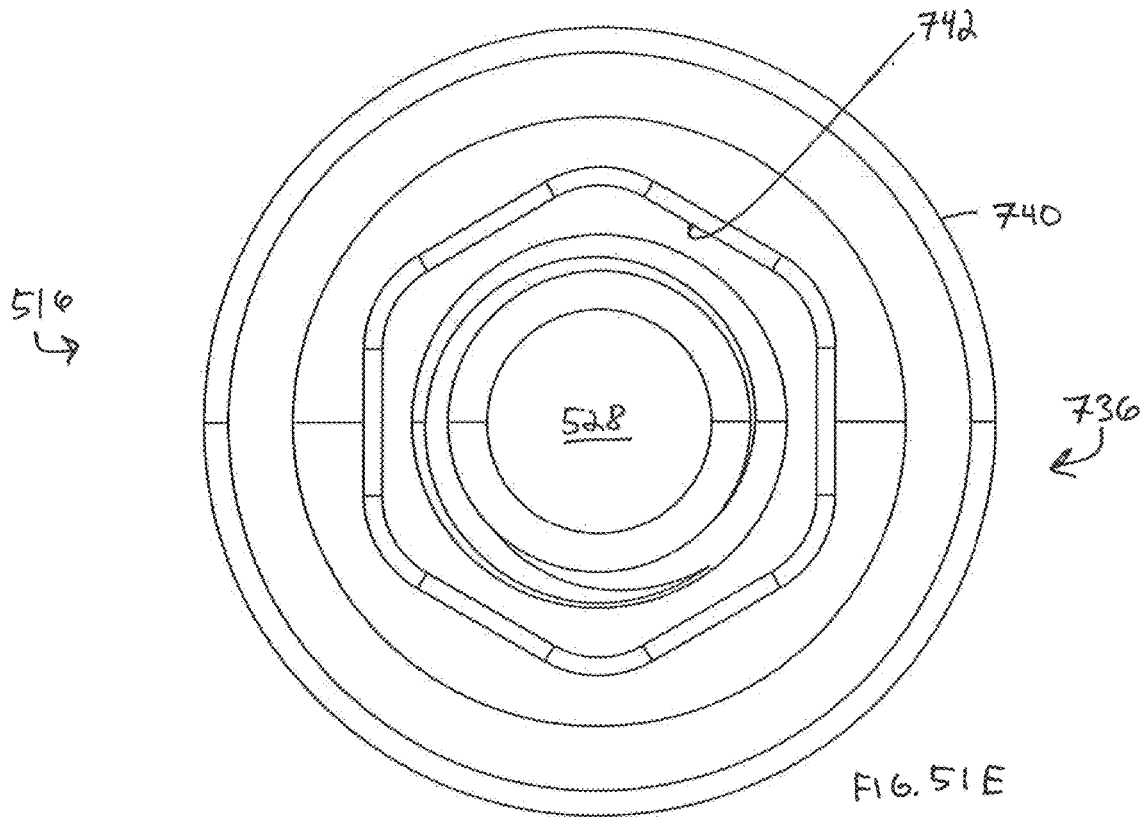

FIG. 50







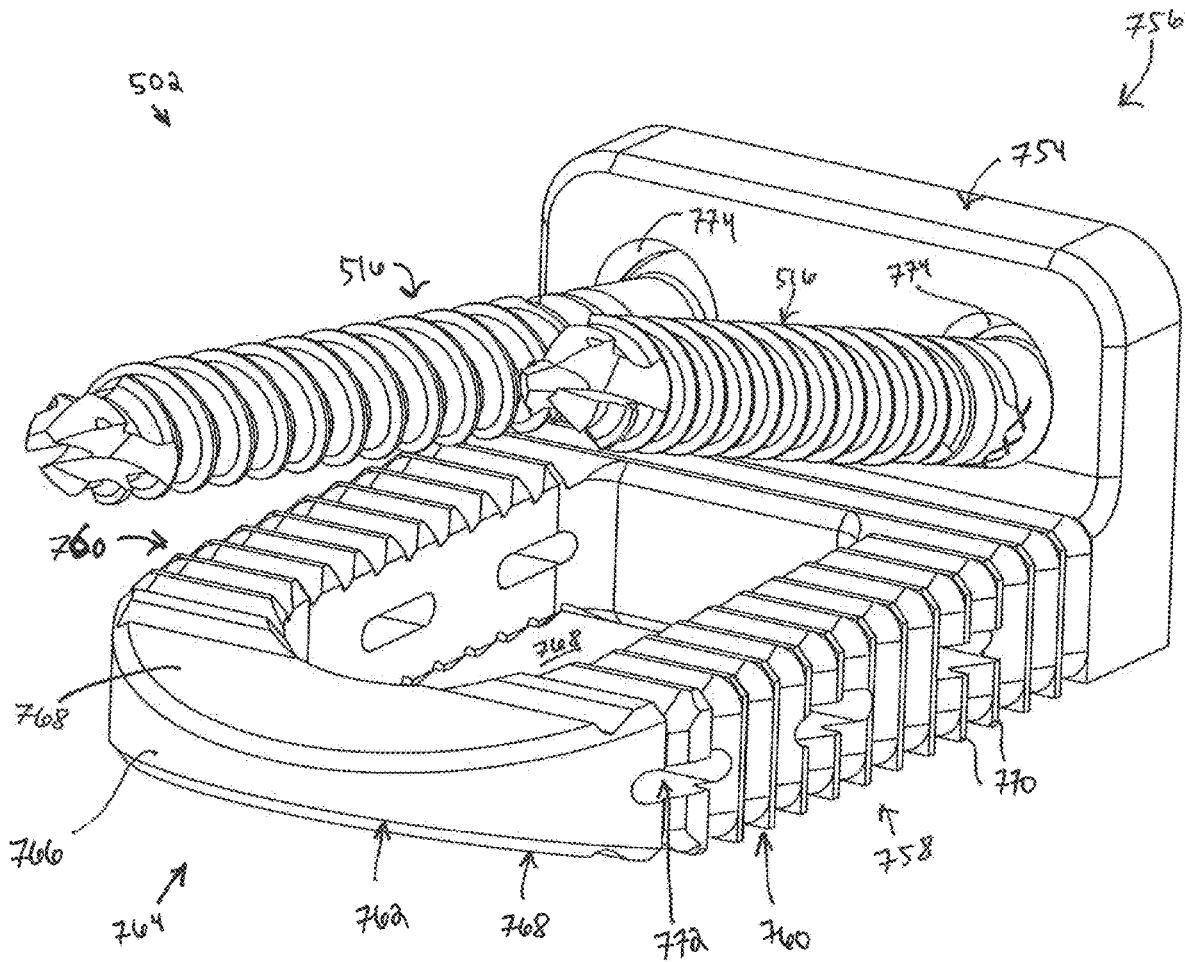

FIG. 52

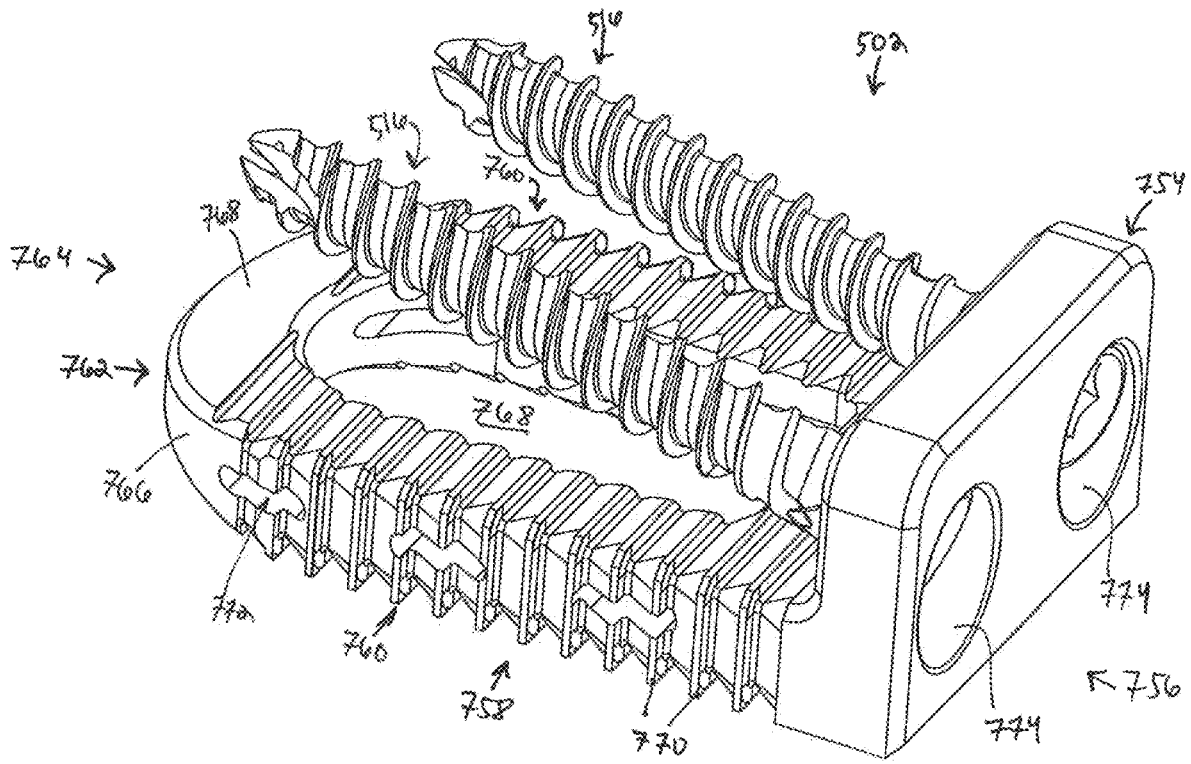

FIG. 53

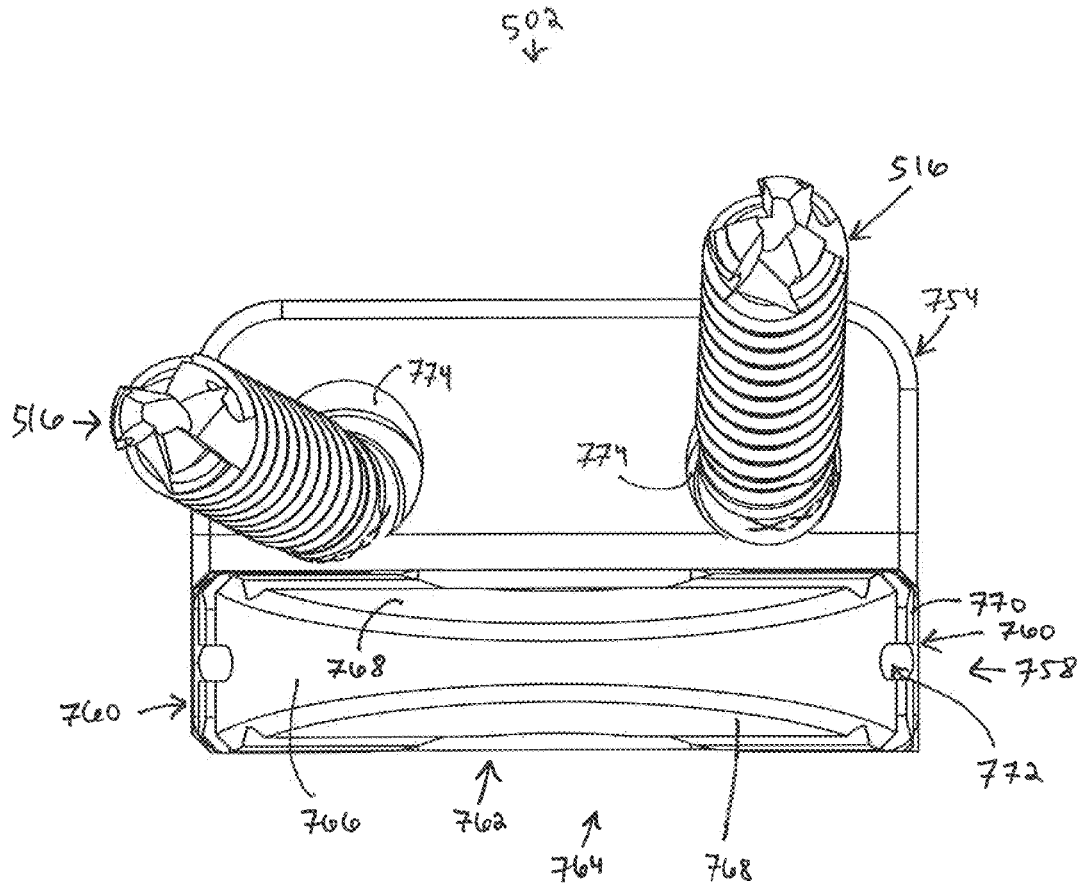

FIG. 54

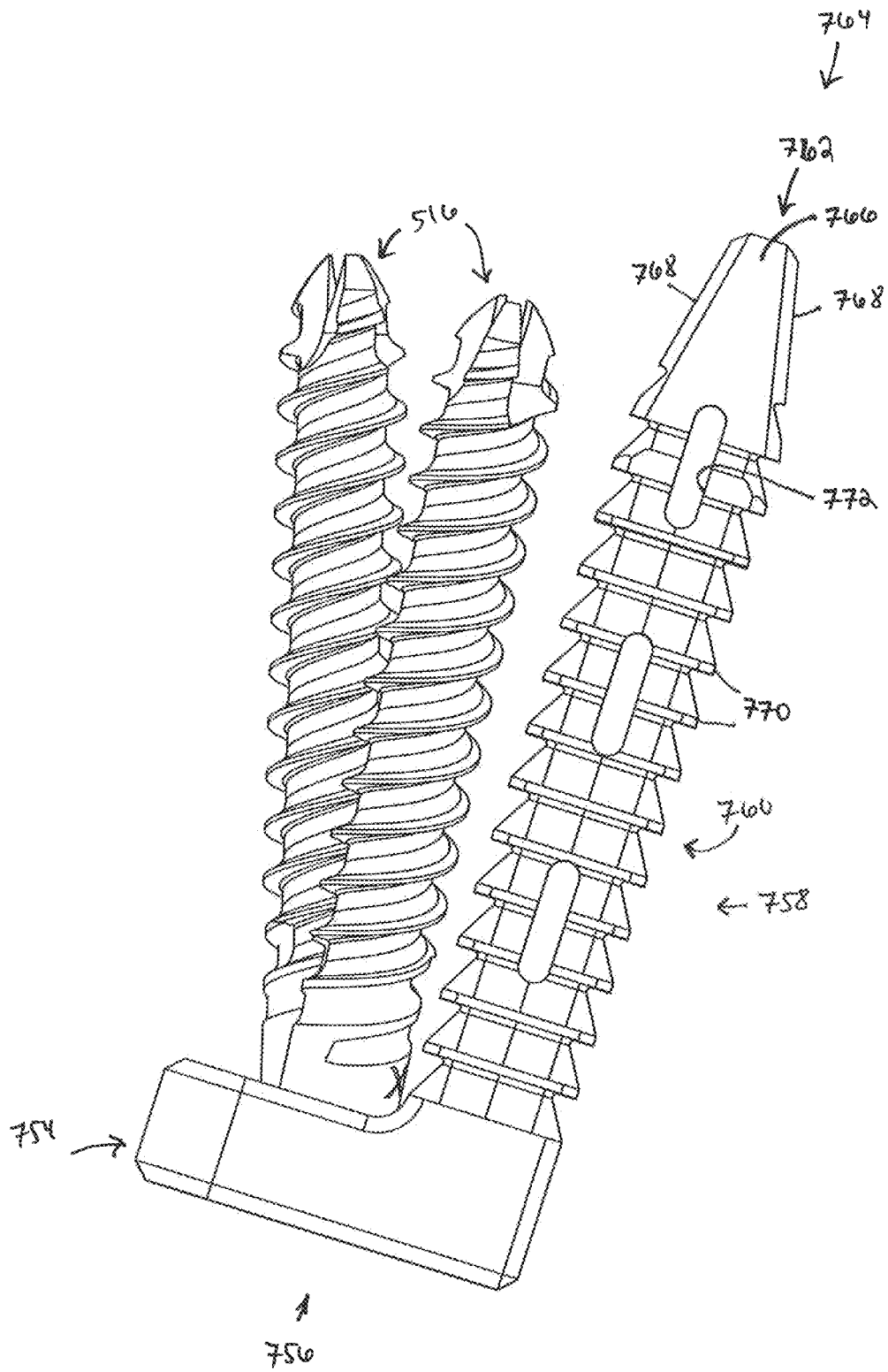

FIG. 55

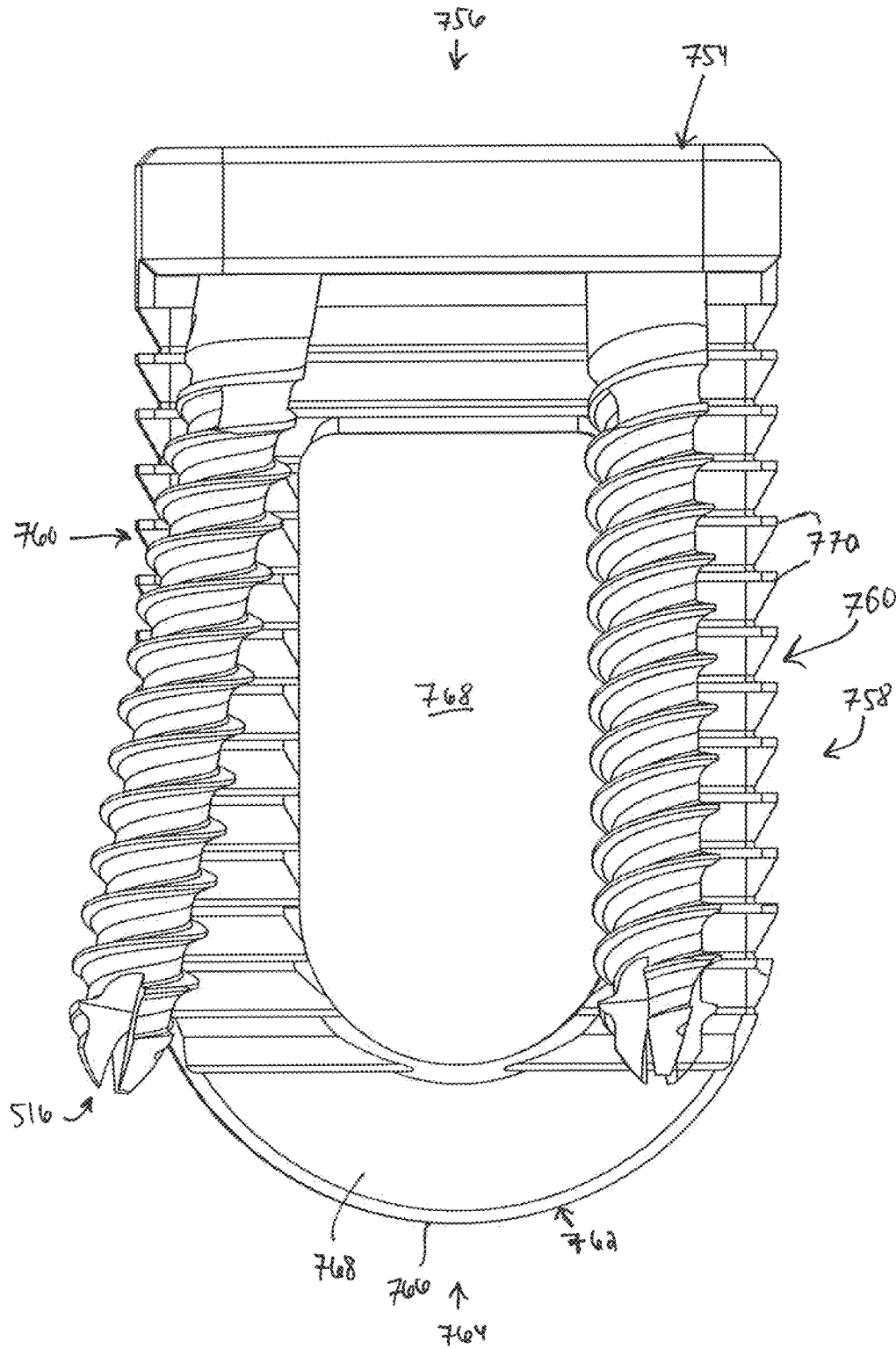

FIG. 56

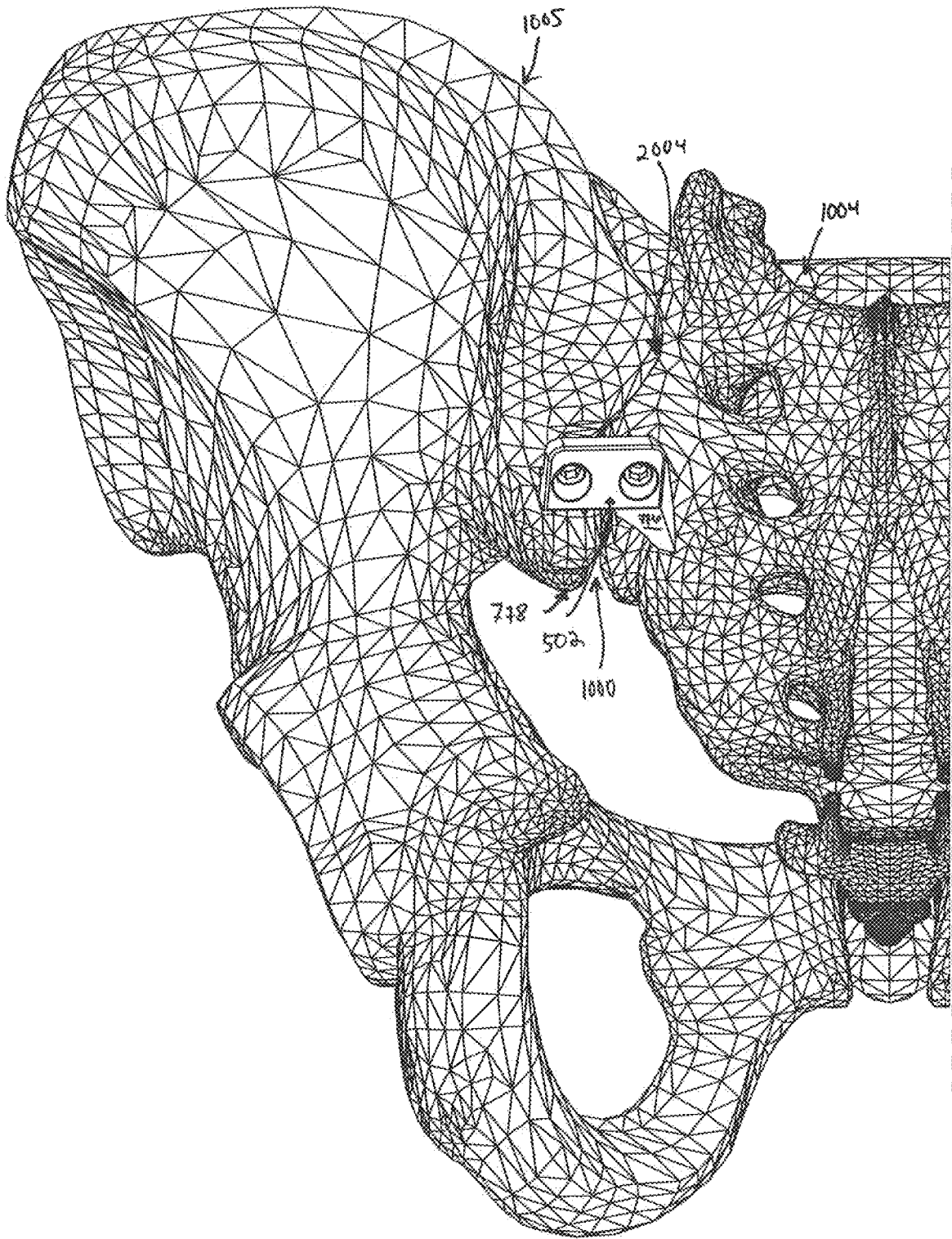

FIG. 57

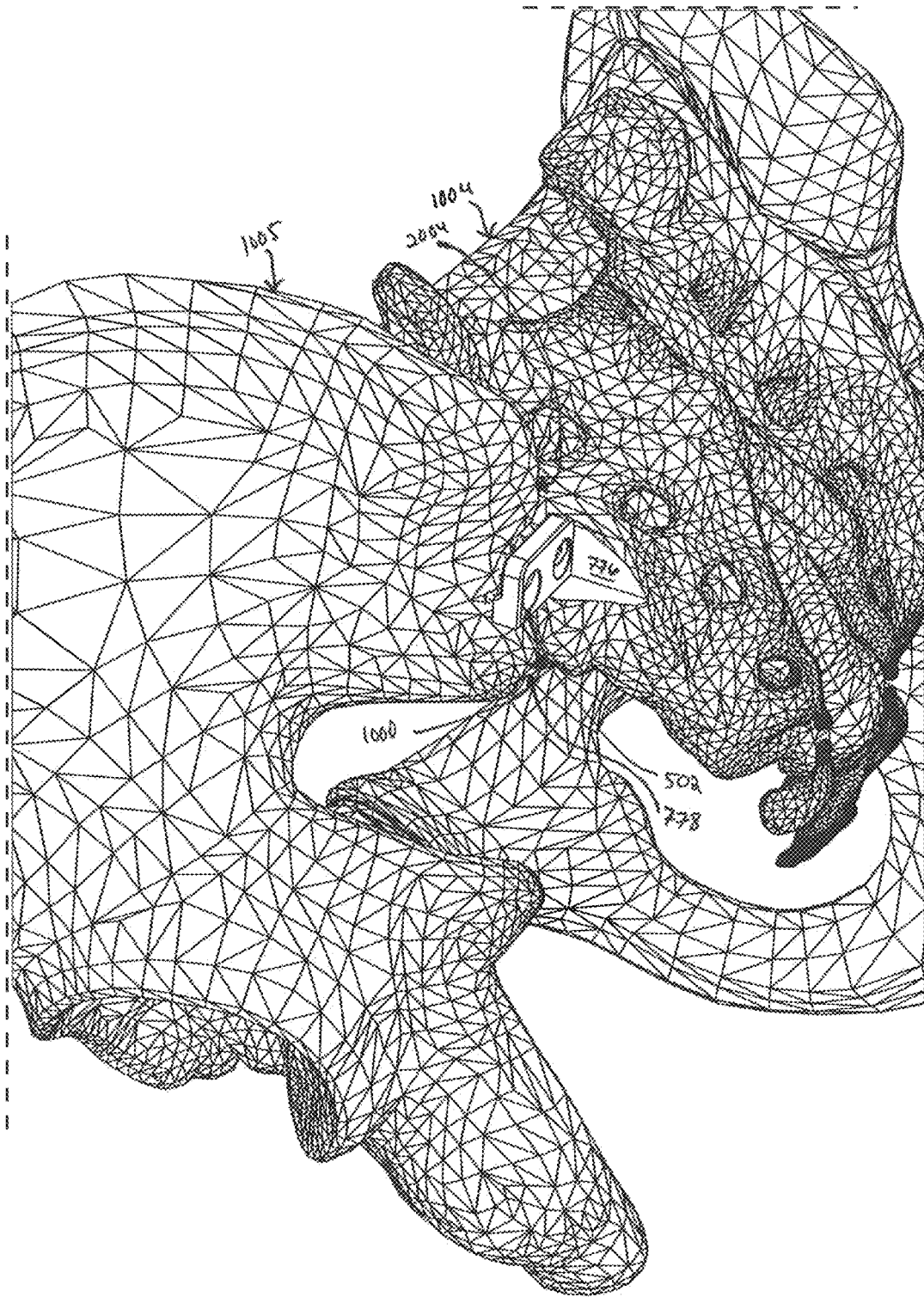

FIG. 58



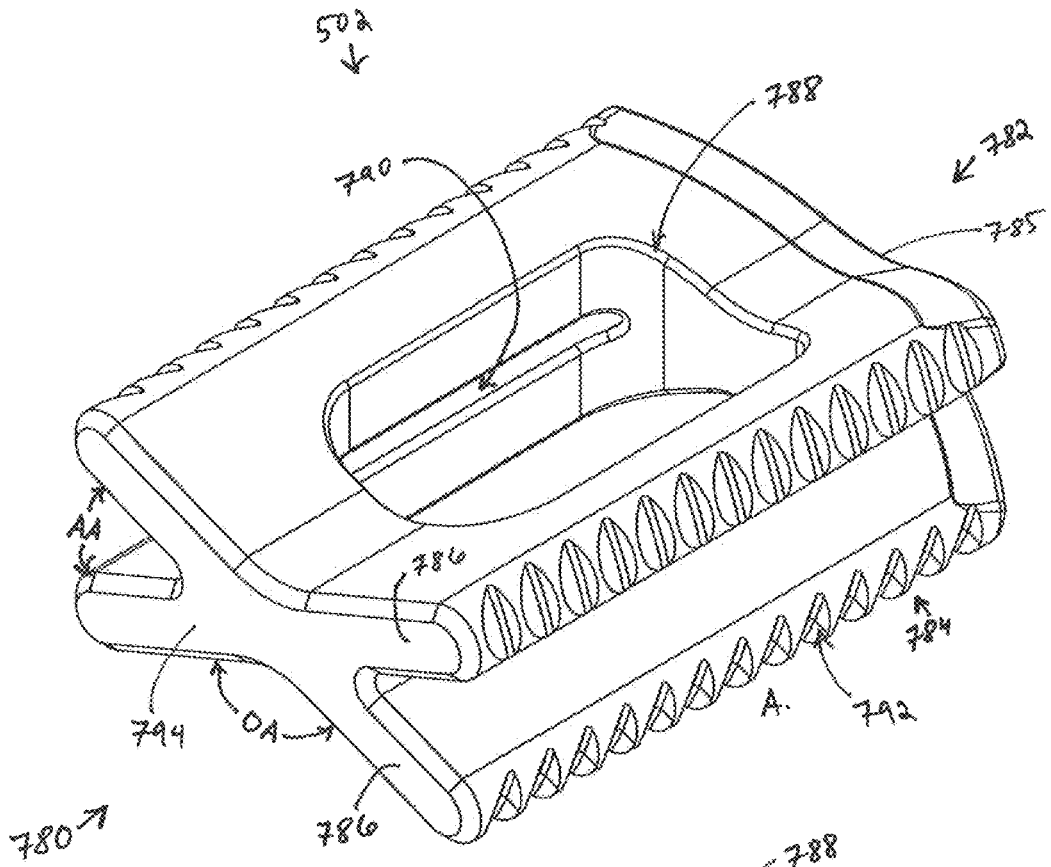

FIG. 59A

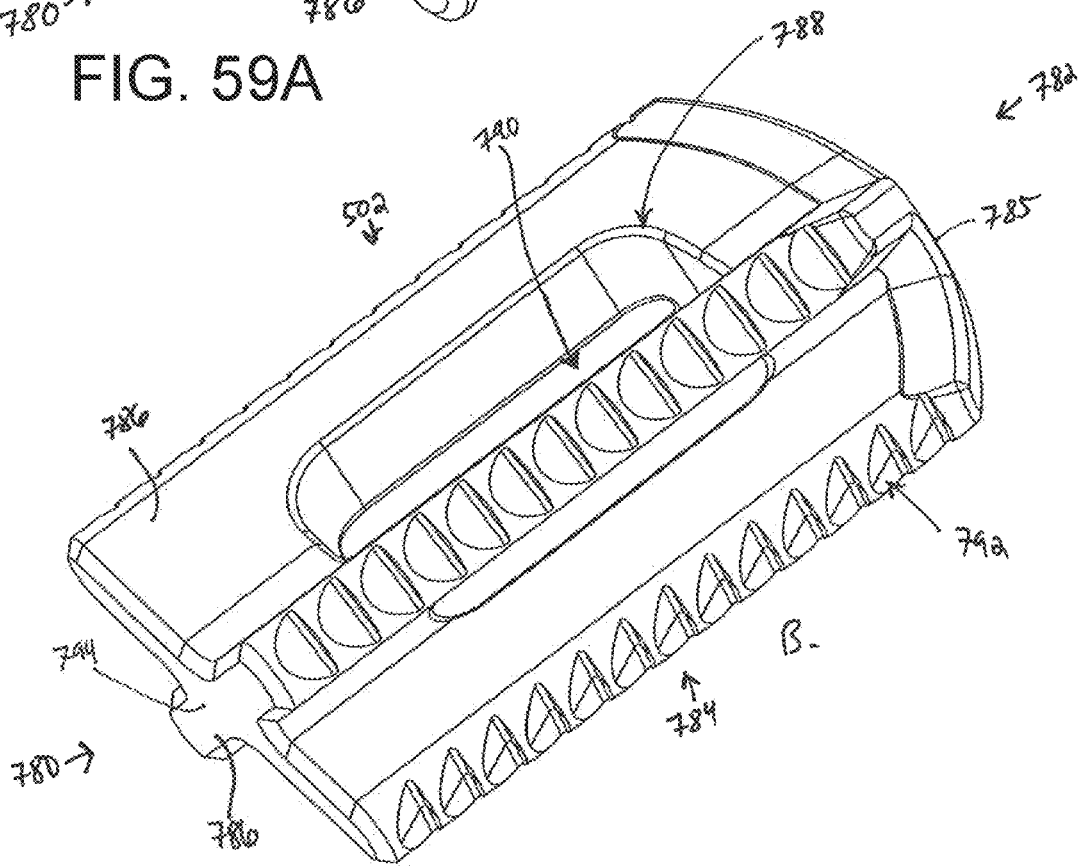
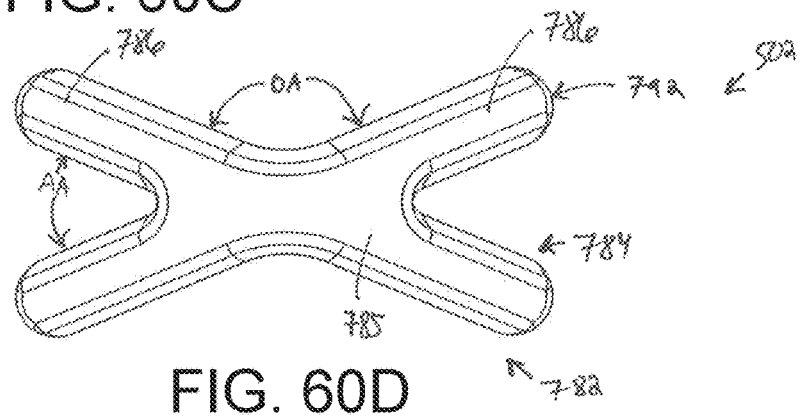
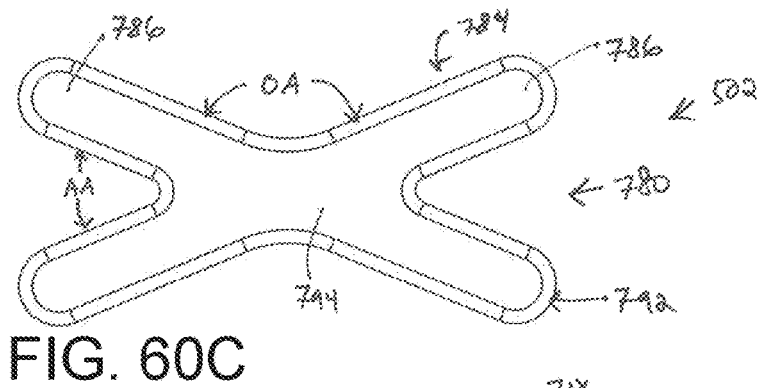
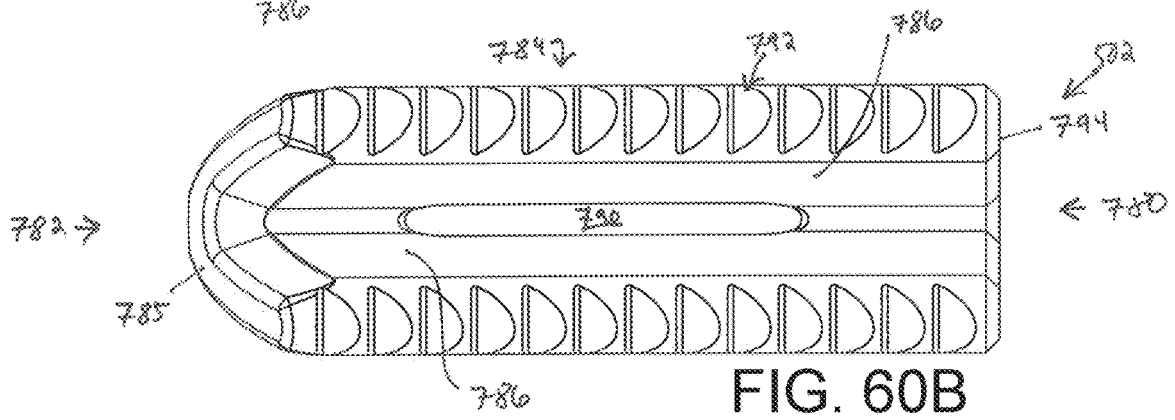
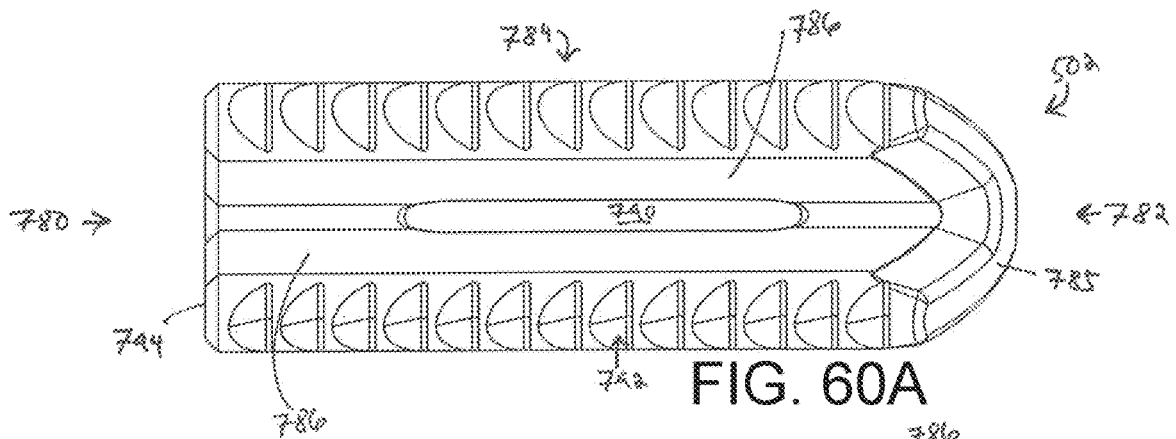

FIG. 59B



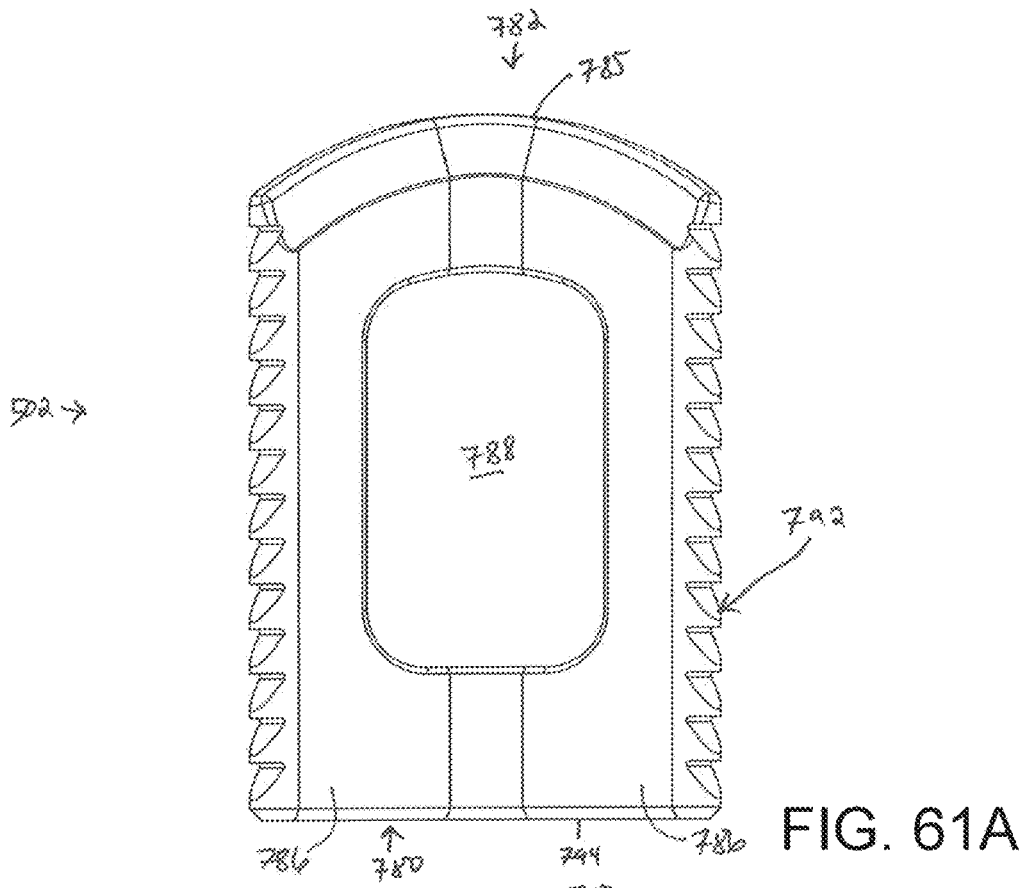

FIG. 61A

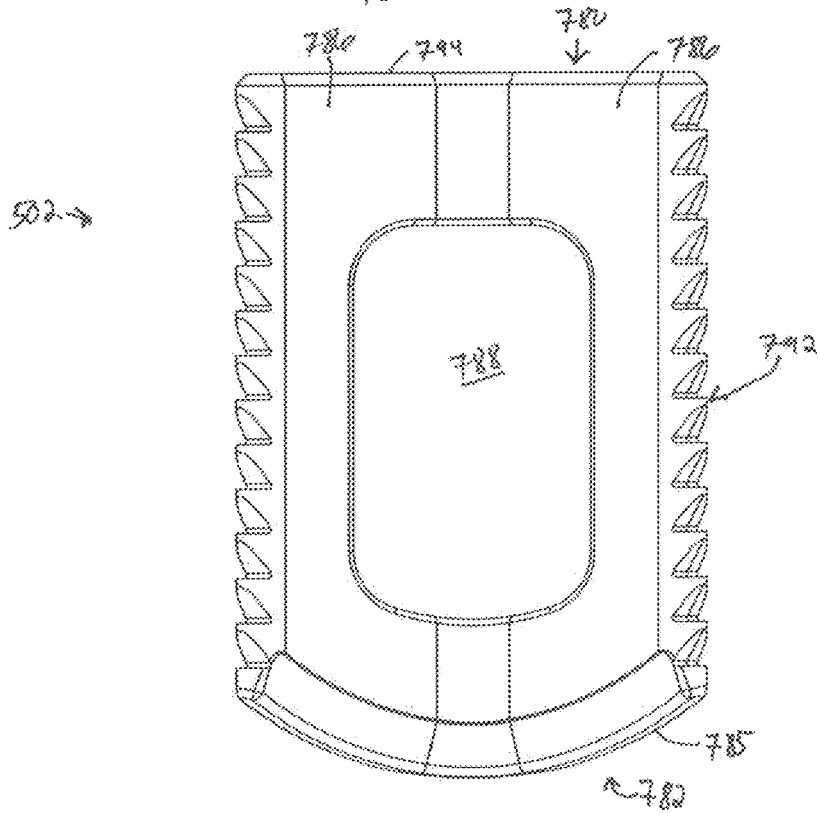

FIG. 61B

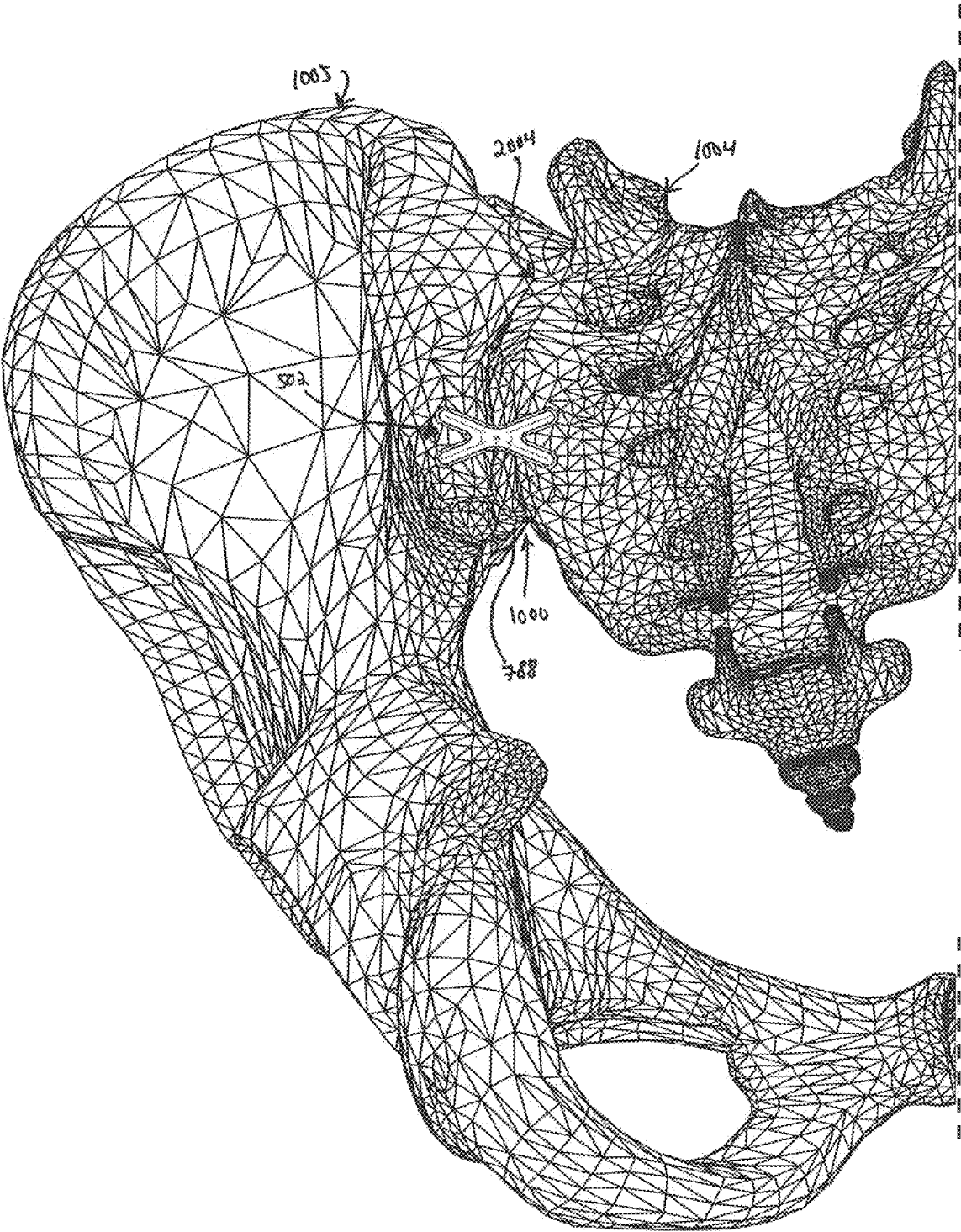

FIG. 62

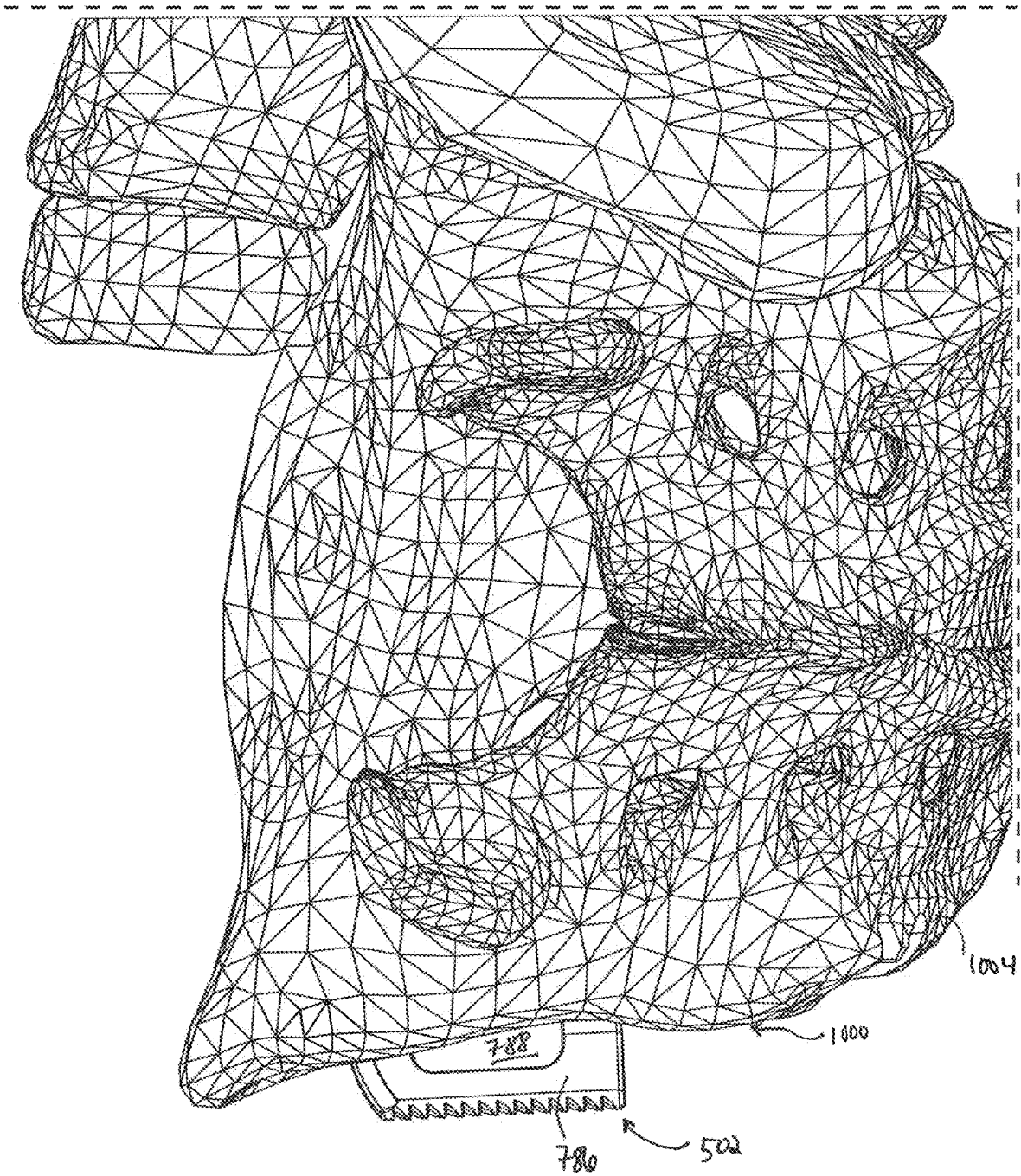

FIG. 63

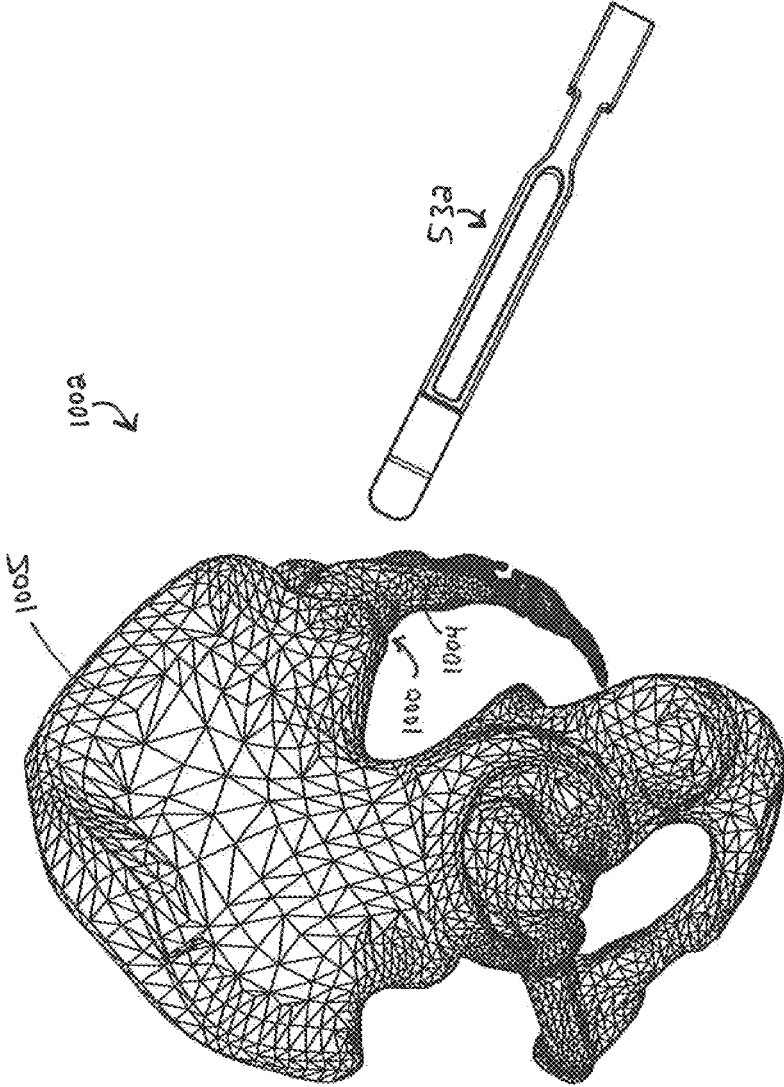

FIG. 64

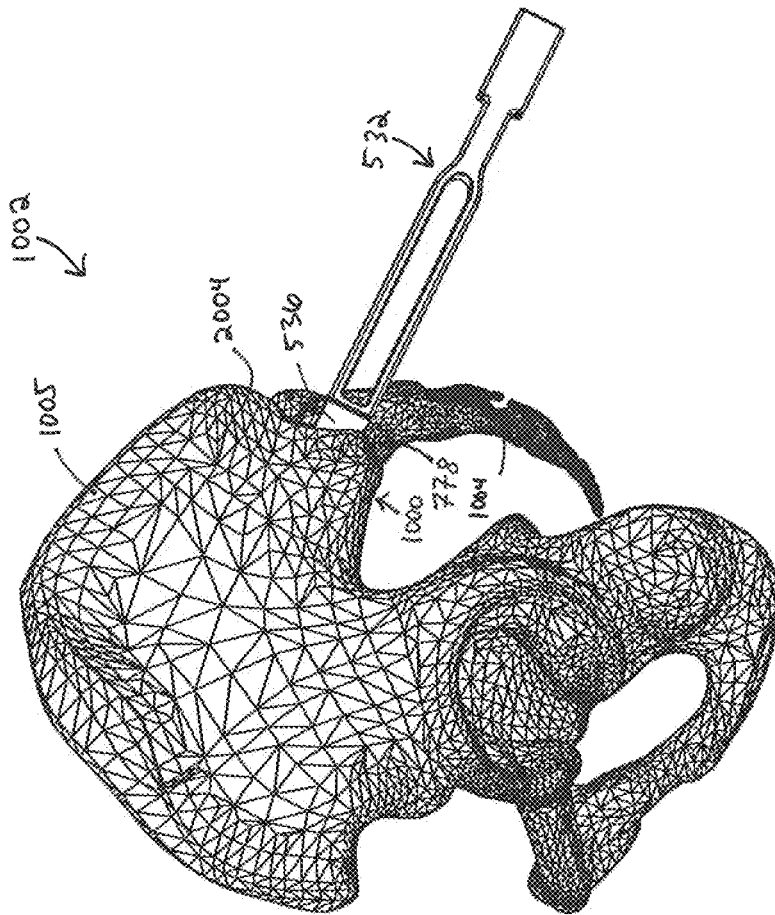

FIG. 65

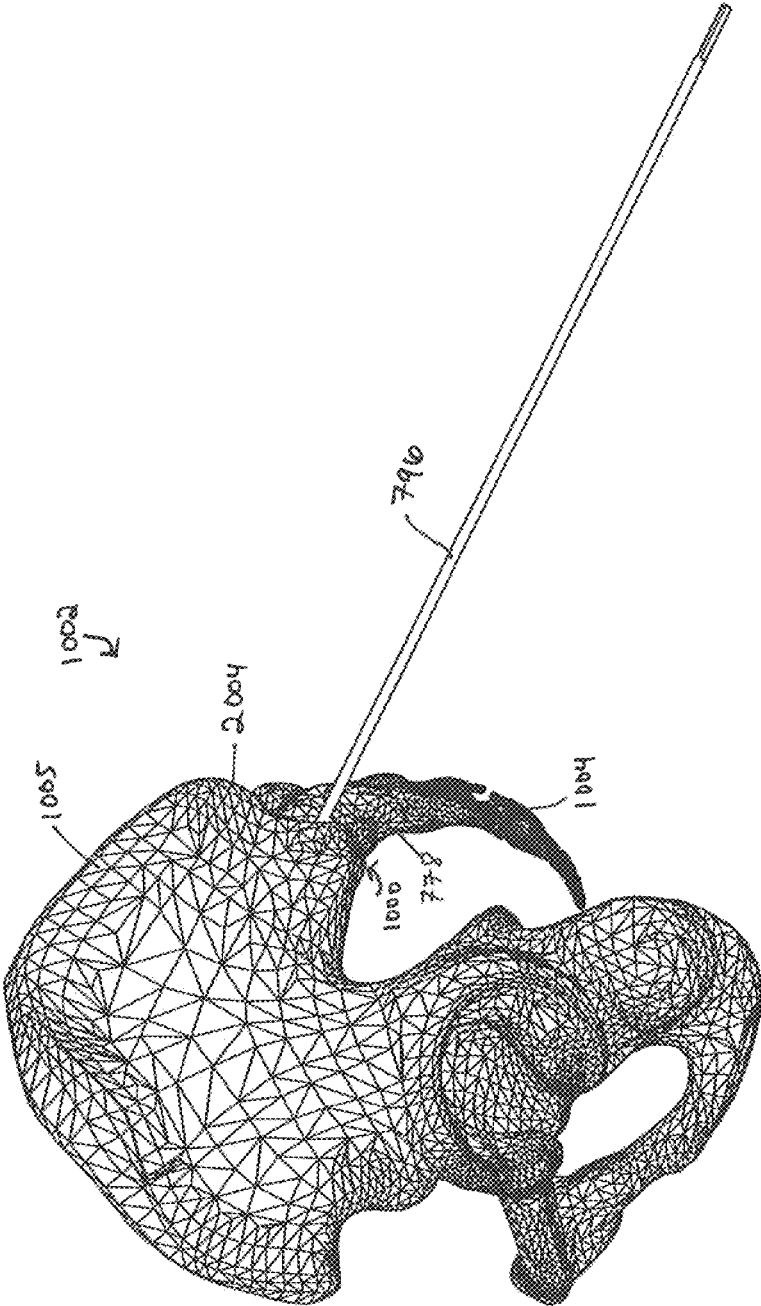

FIG. 66



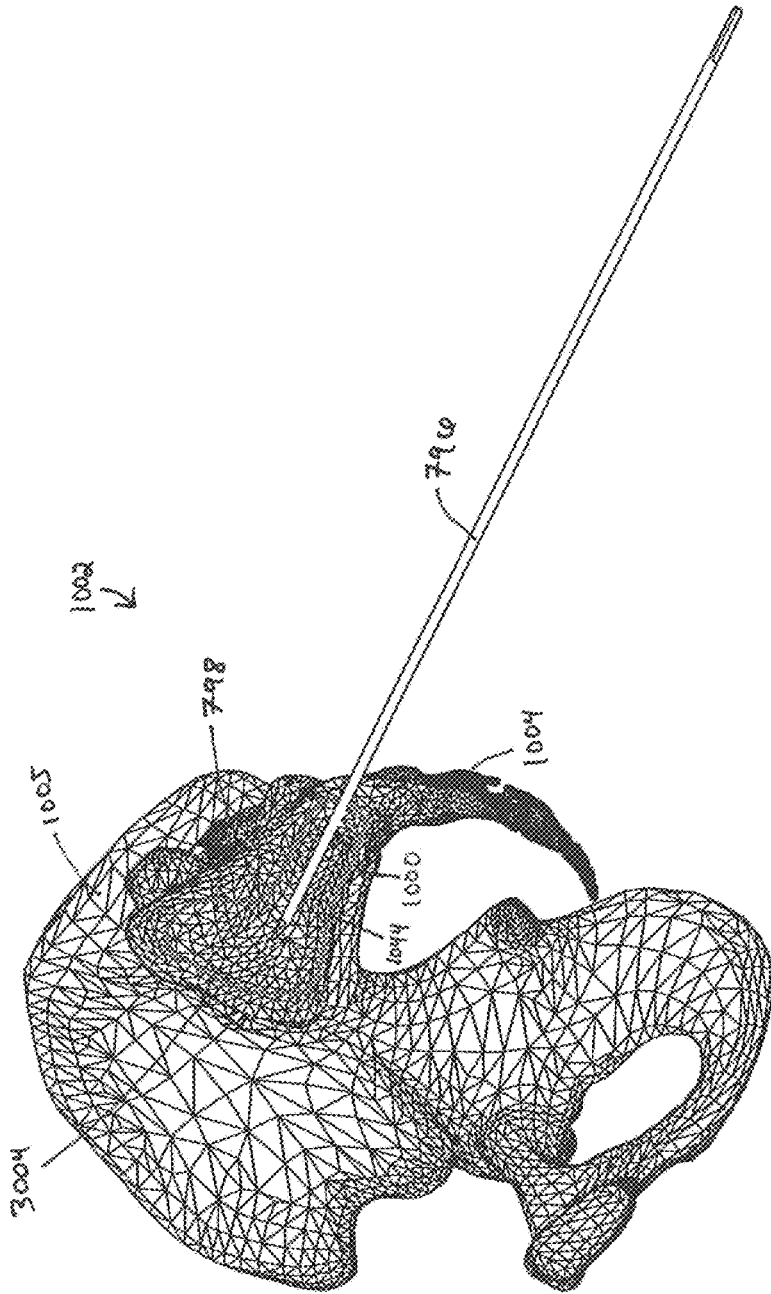

FIG. 67

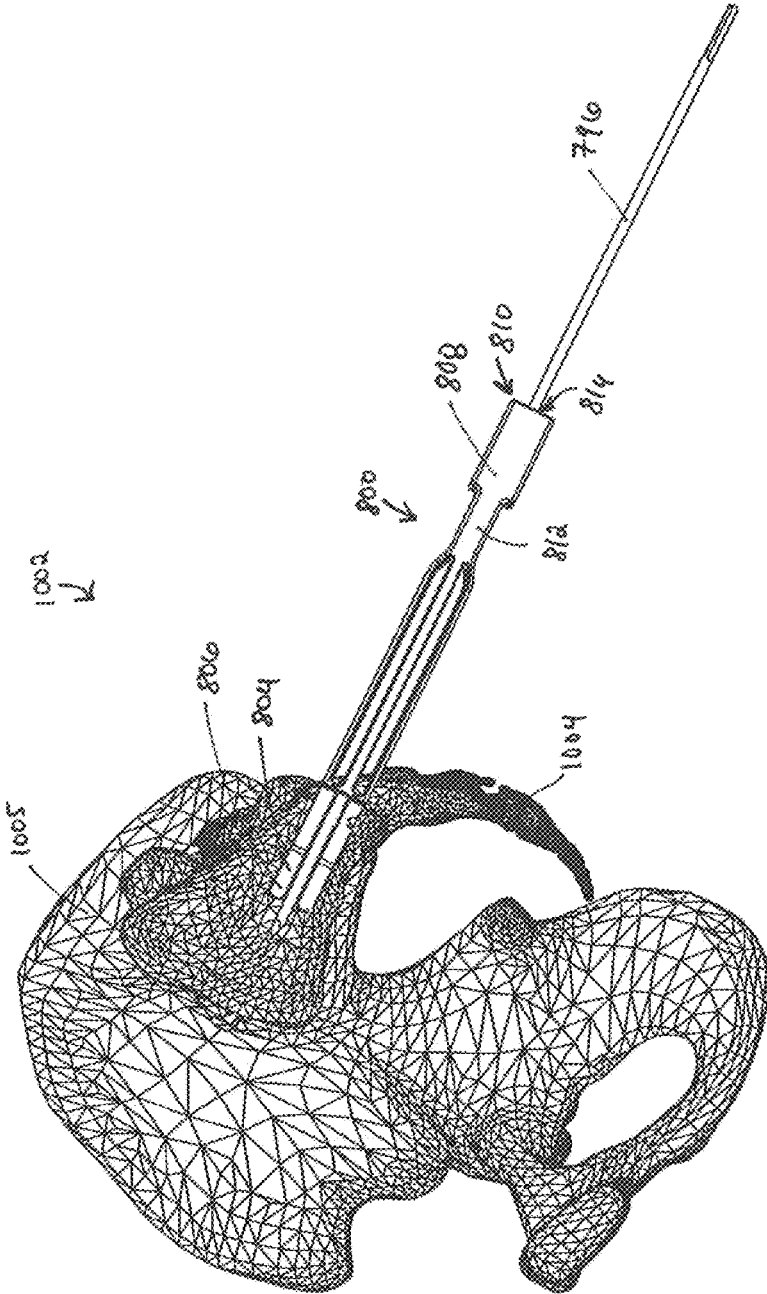

FIG. 68

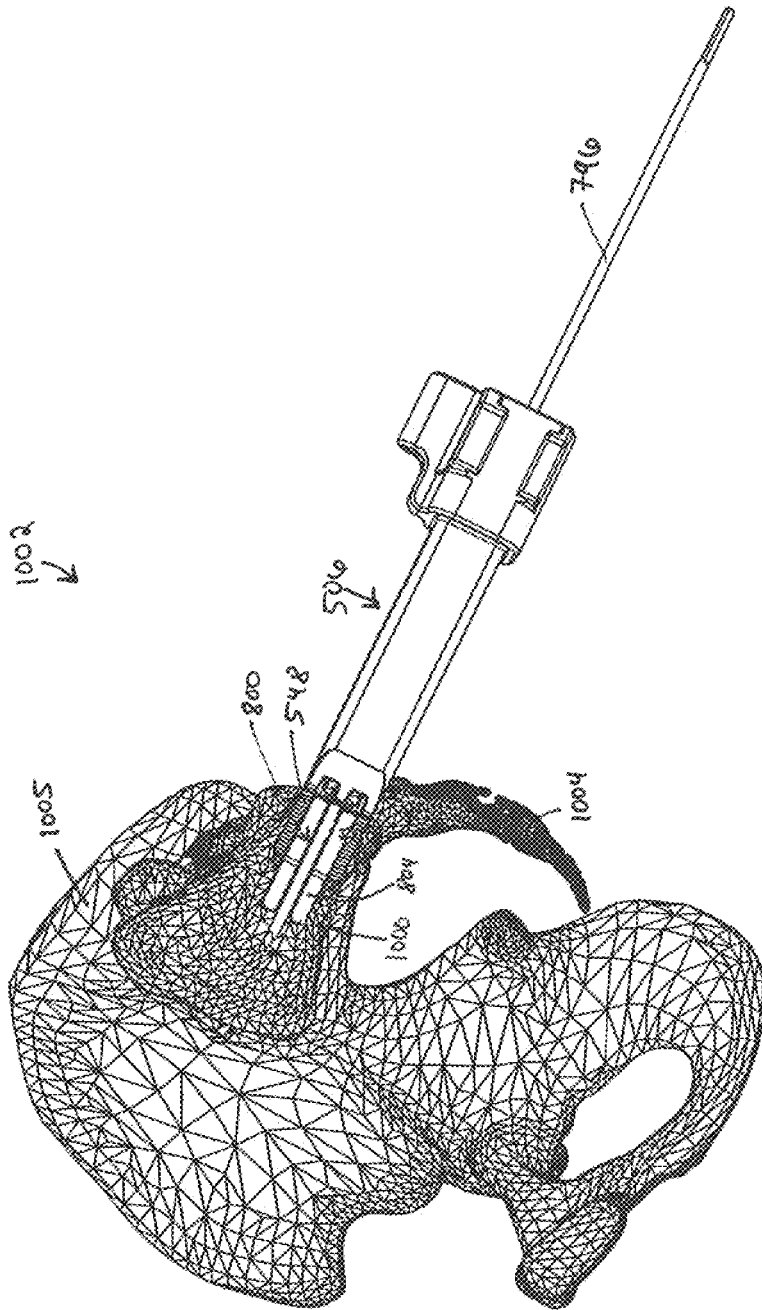

FIG. 69

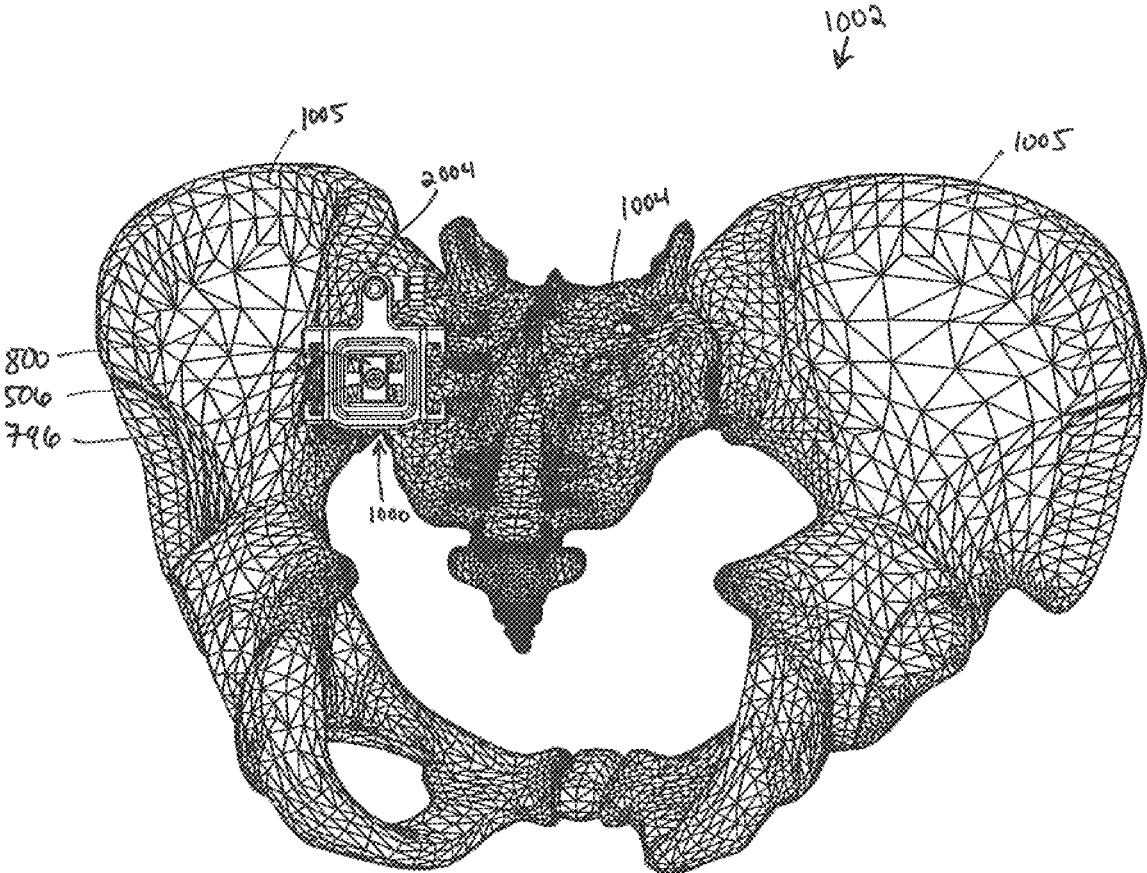

FIG. 70

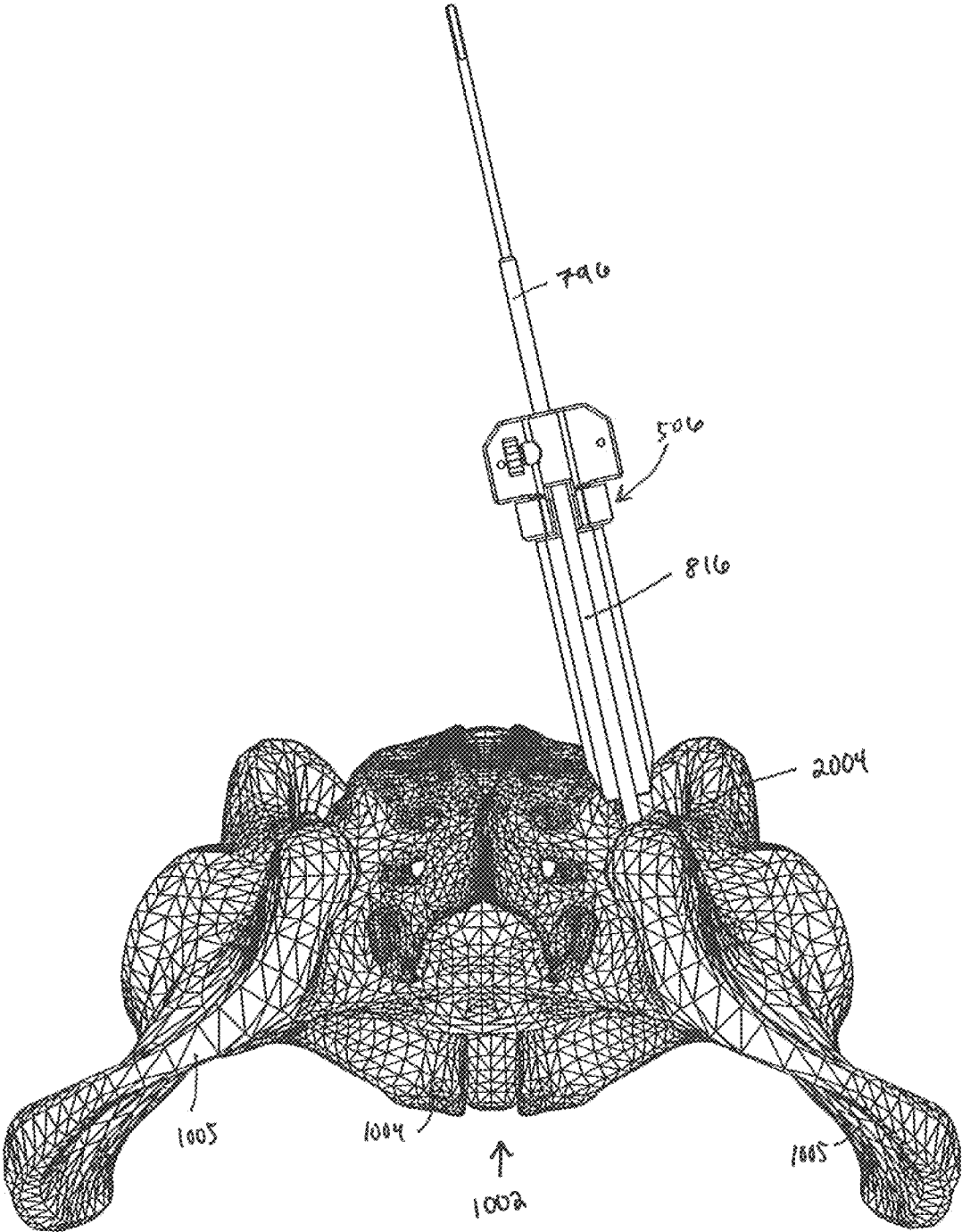

FIG. 71

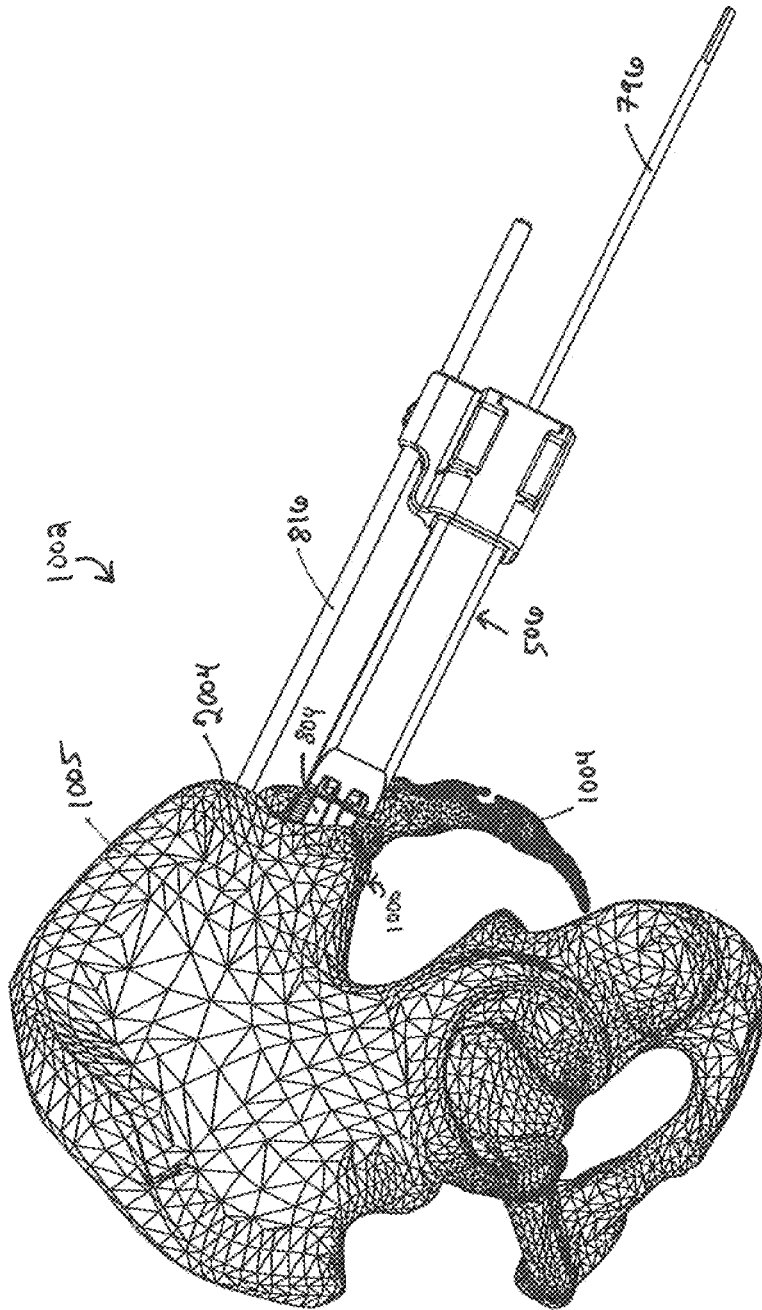

FIG. 72

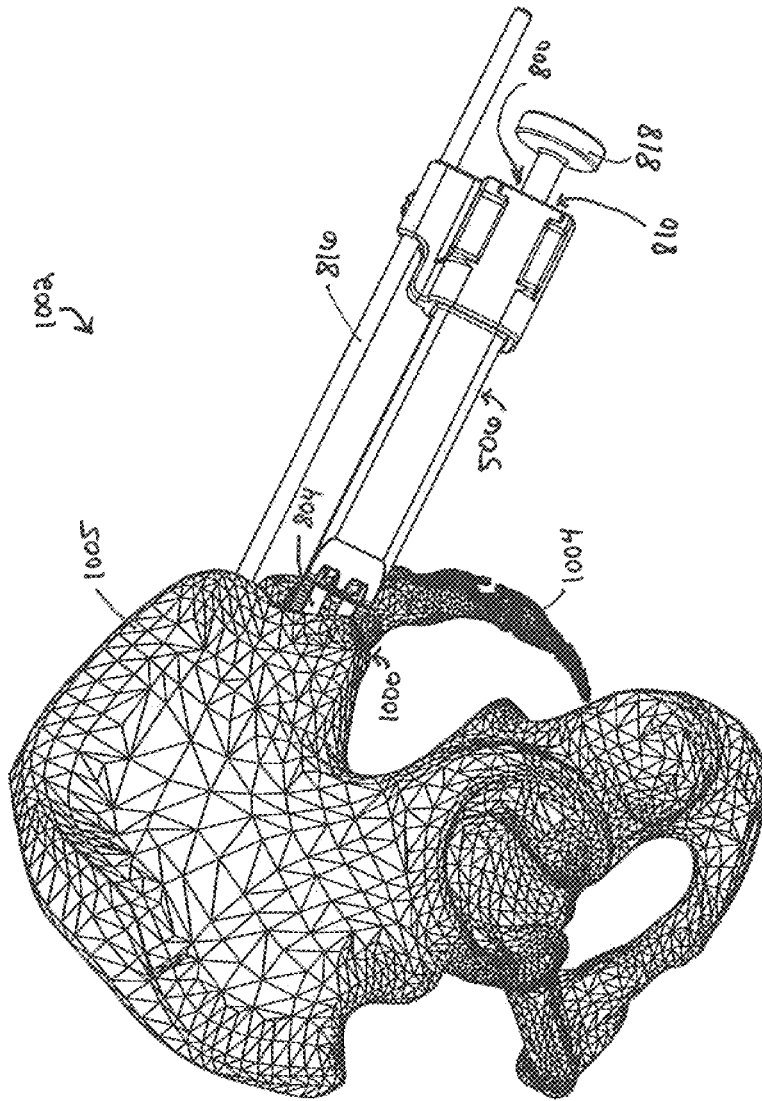

FIG. 73

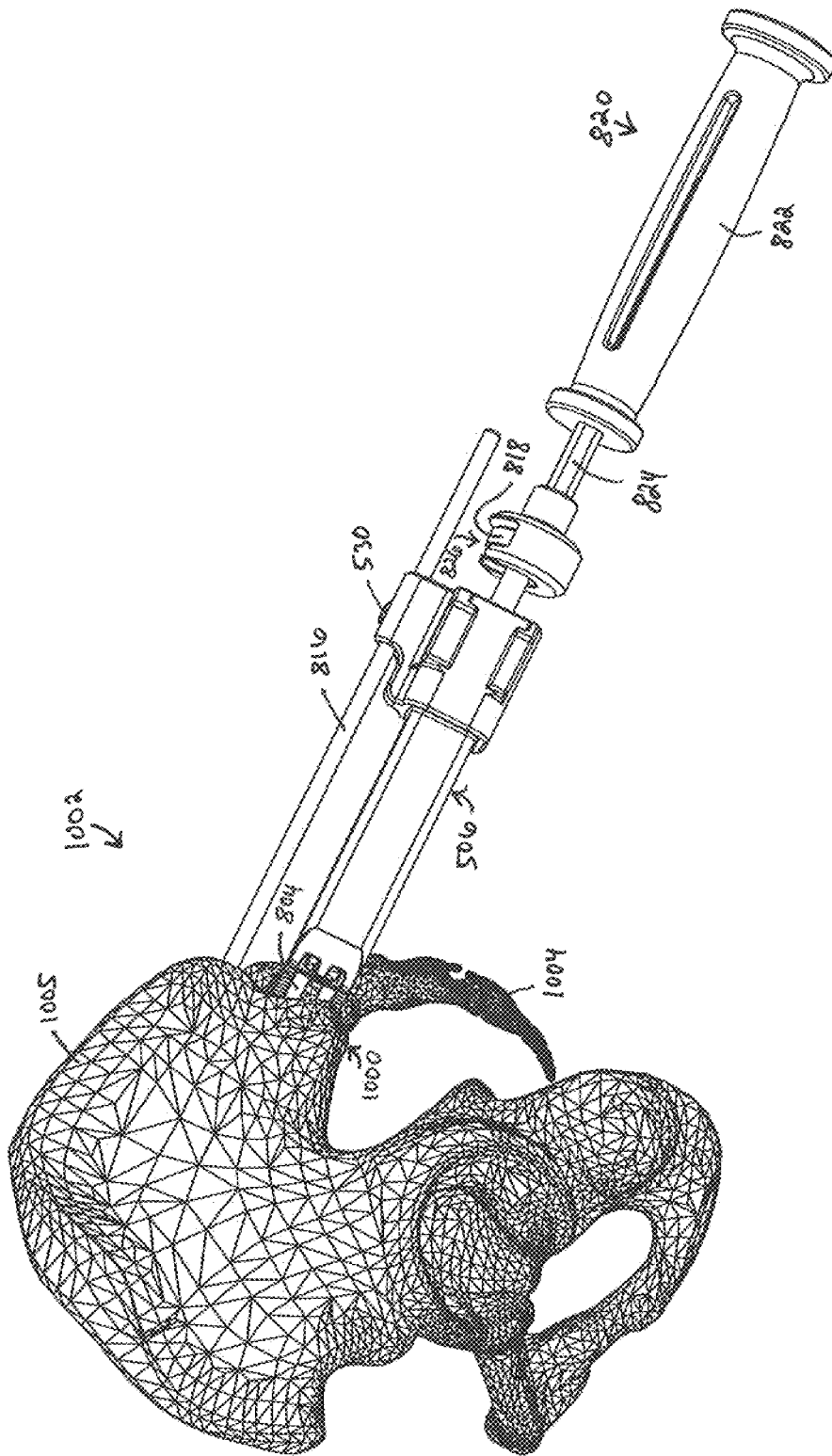

FIG. 74



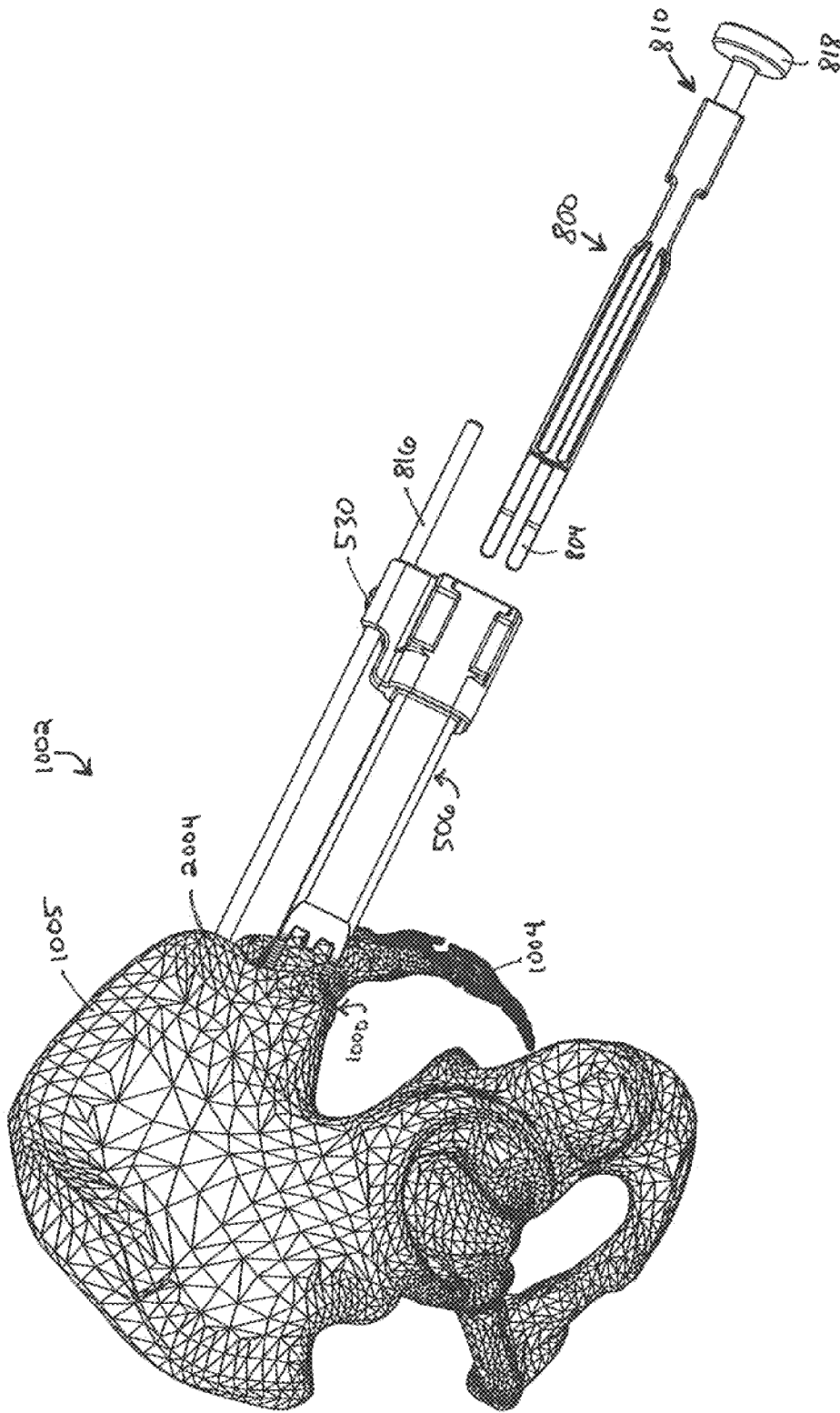

FIG. 75

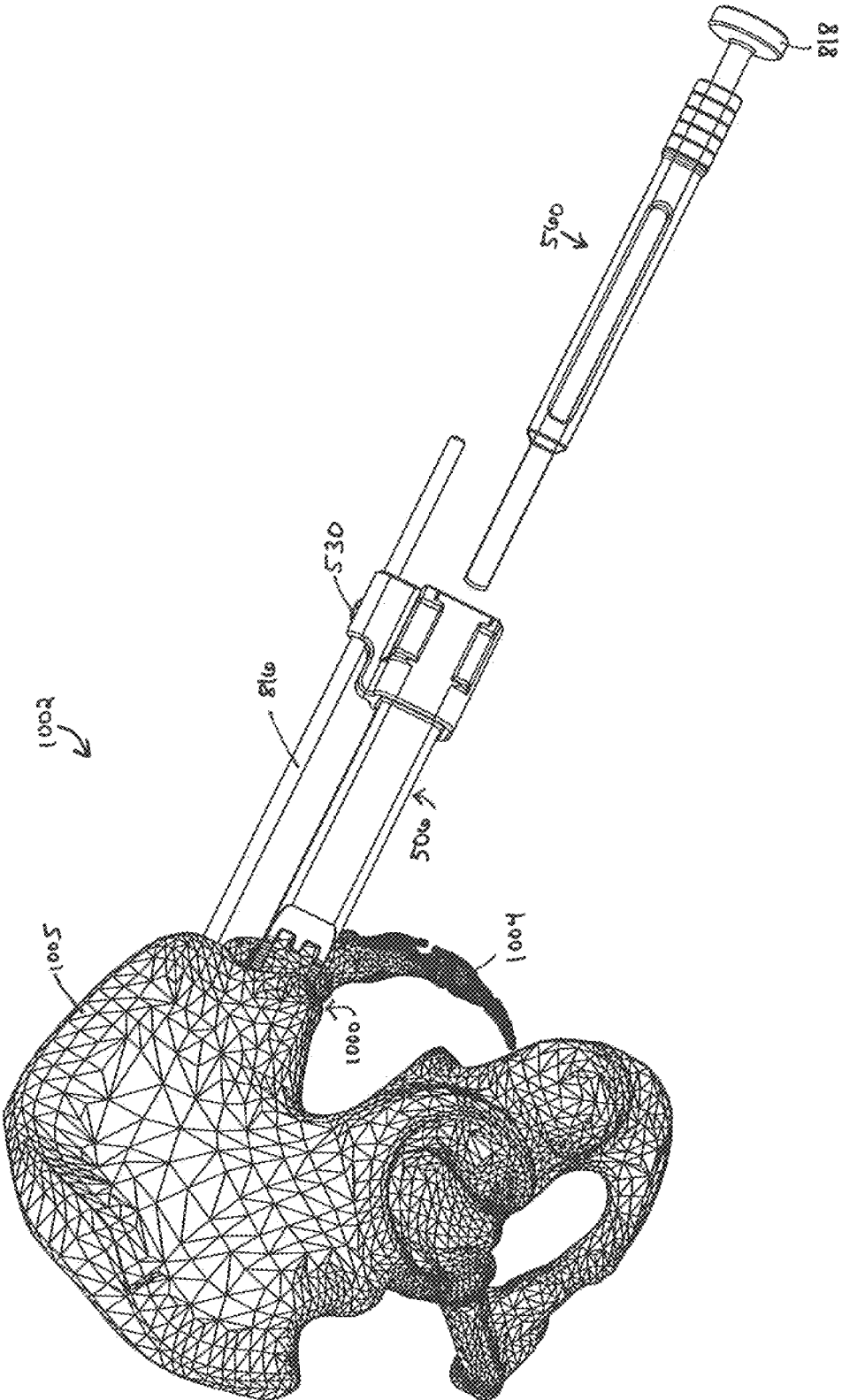

FIG. 76

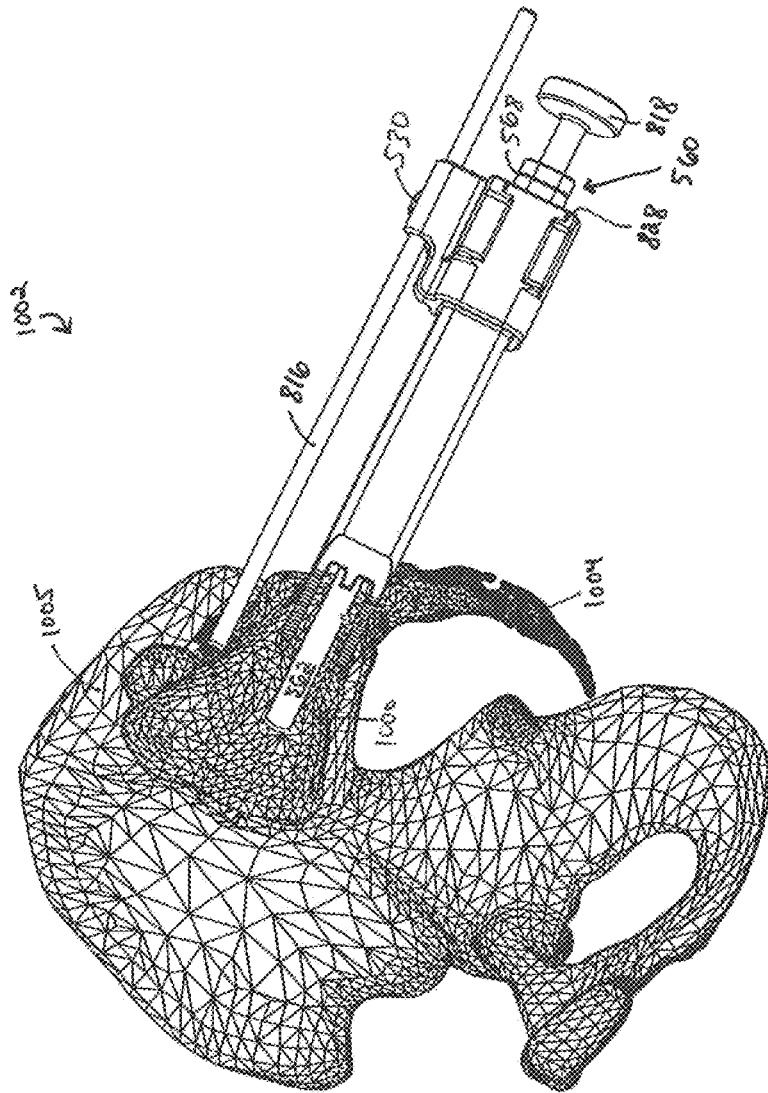

FIG. 77

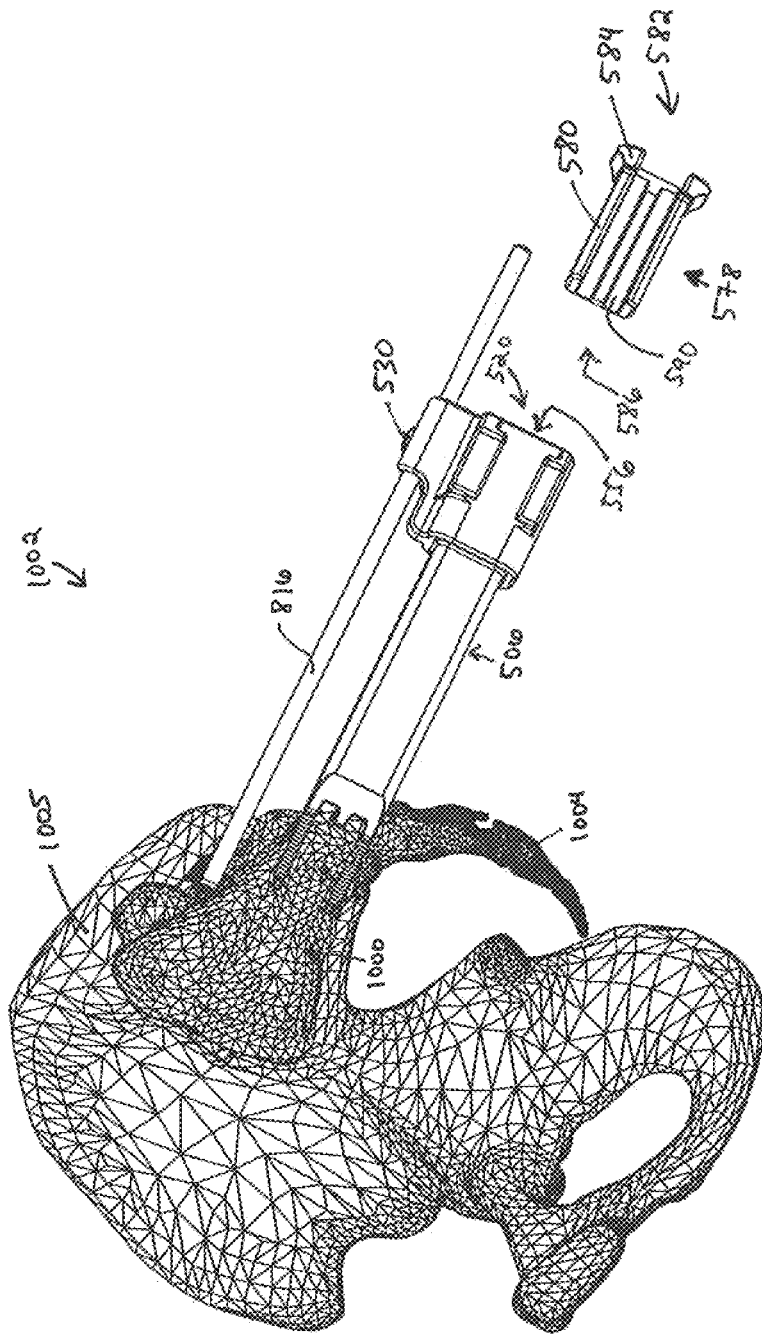

FIG. 78

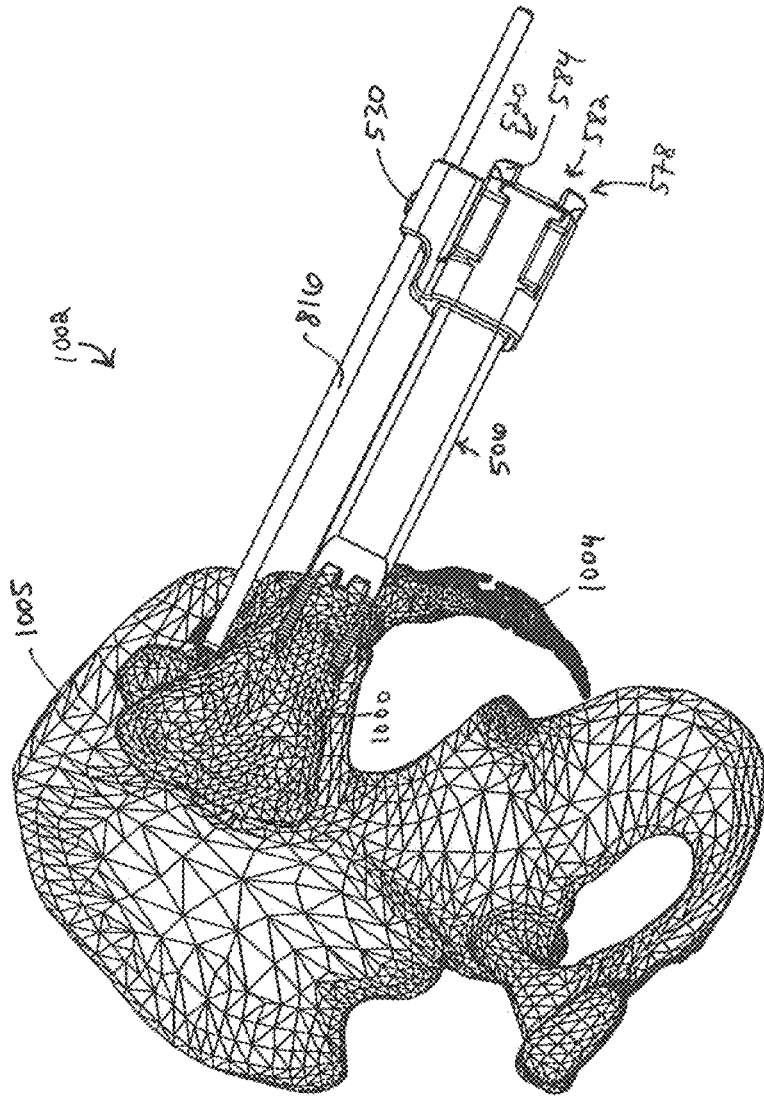

FIG. 79

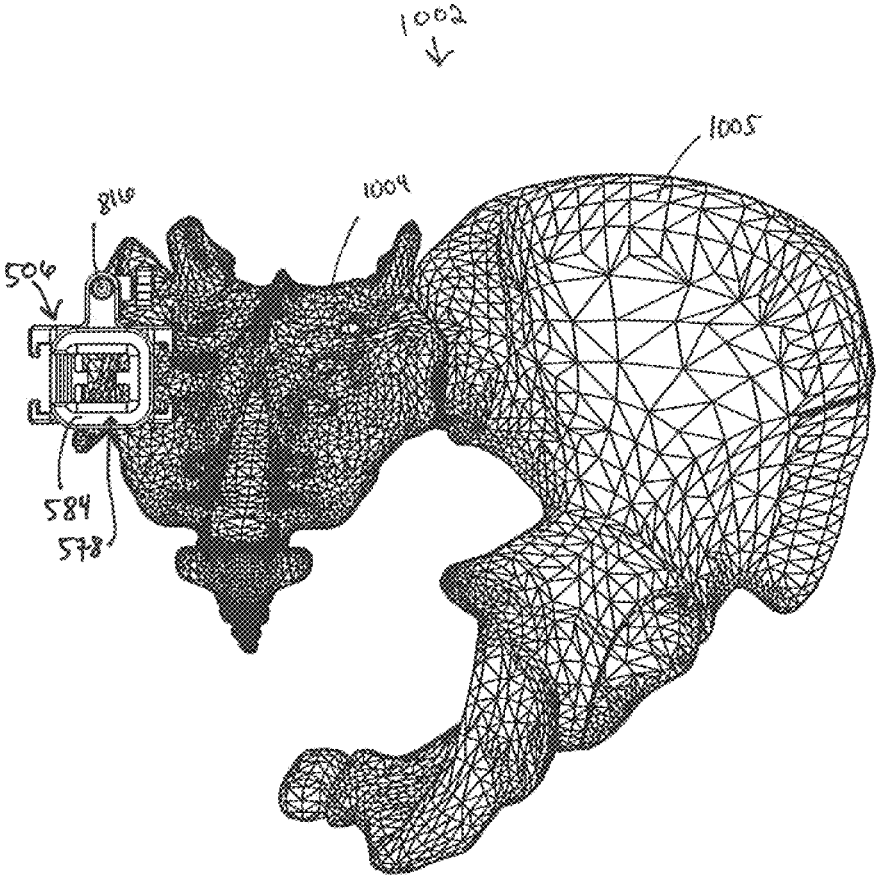

FIG. 80

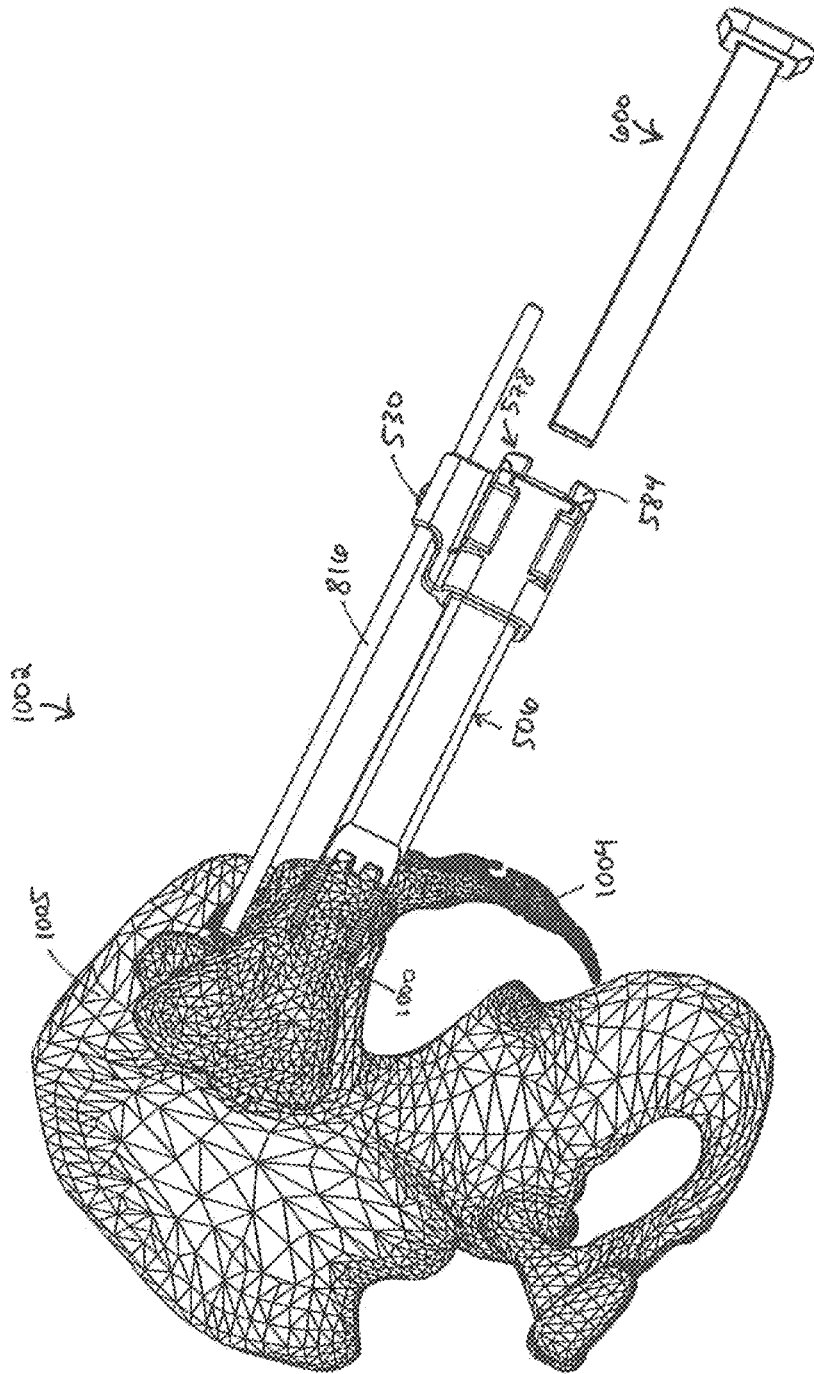

FIG. 81

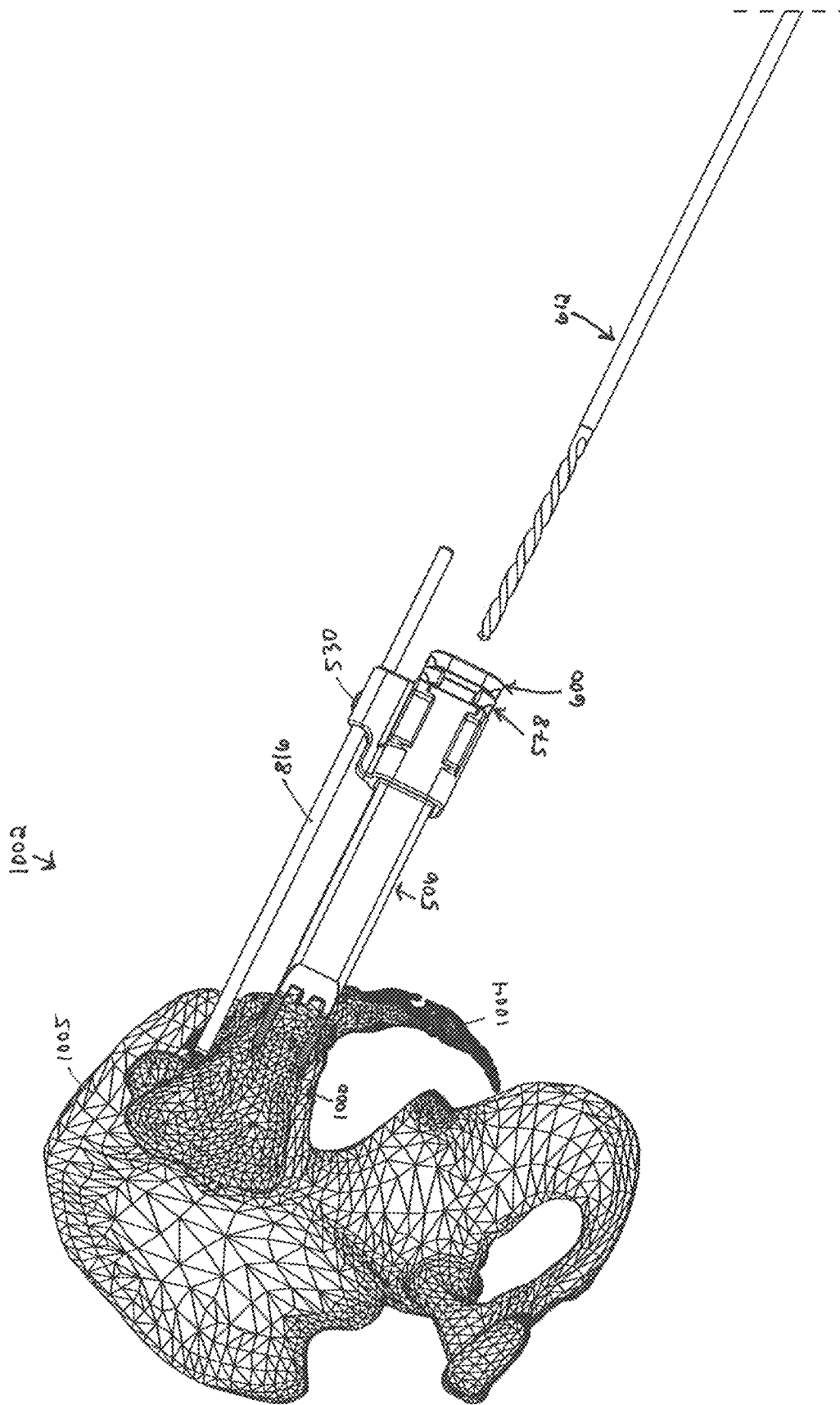

FIG. 82



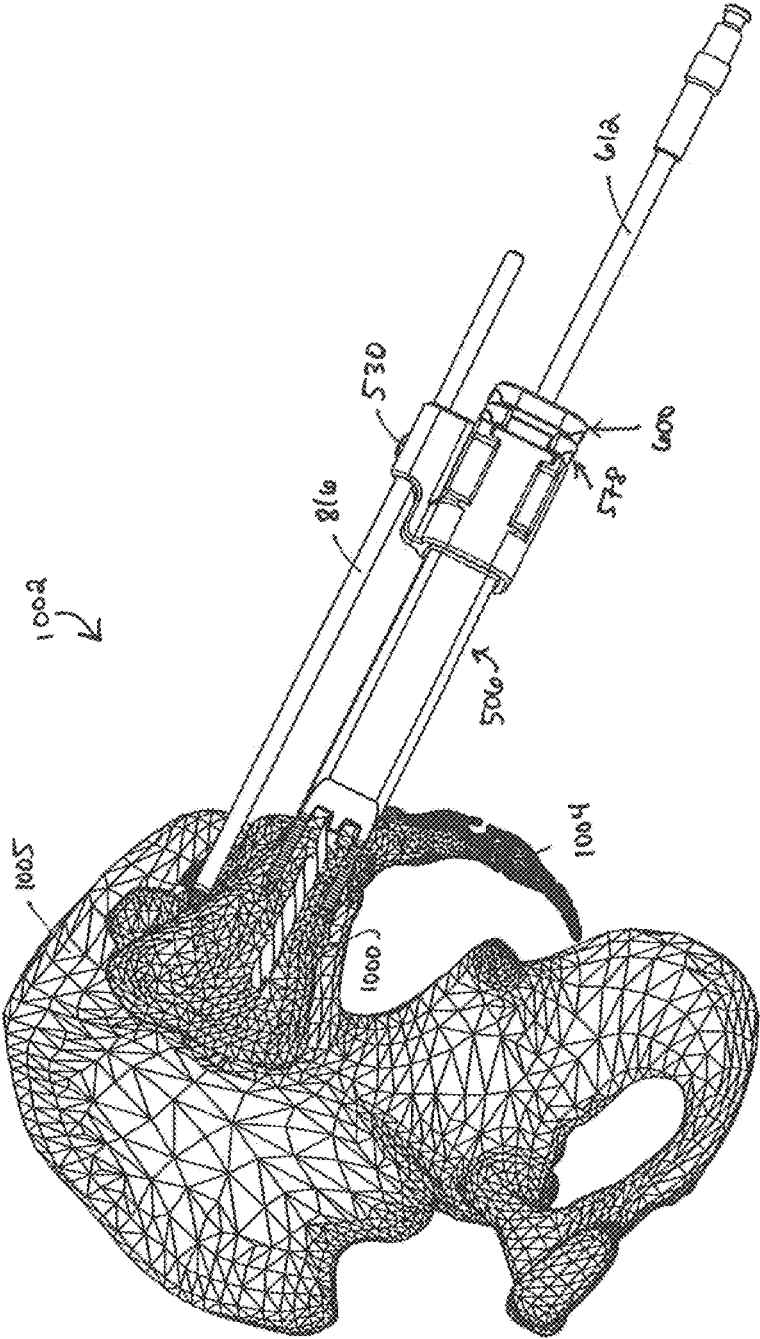

FIG. 83

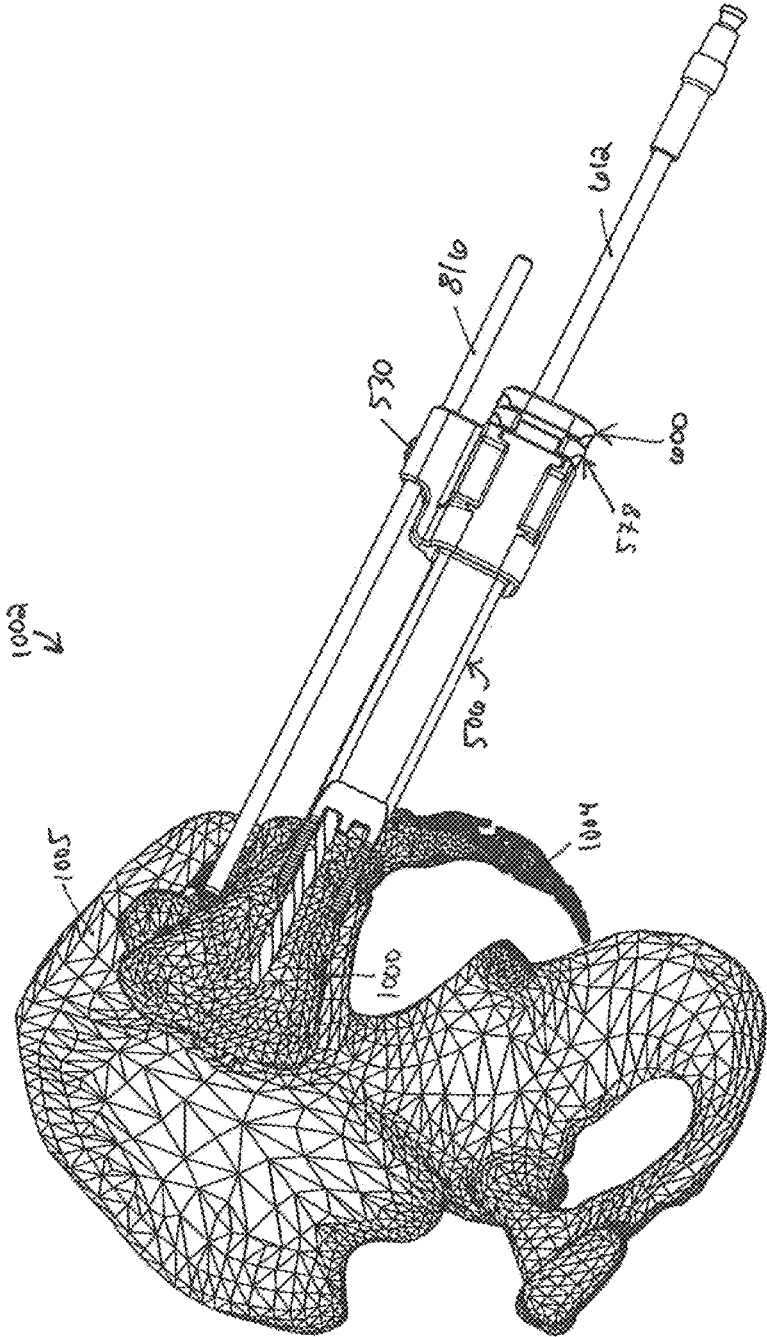

FIG. 84

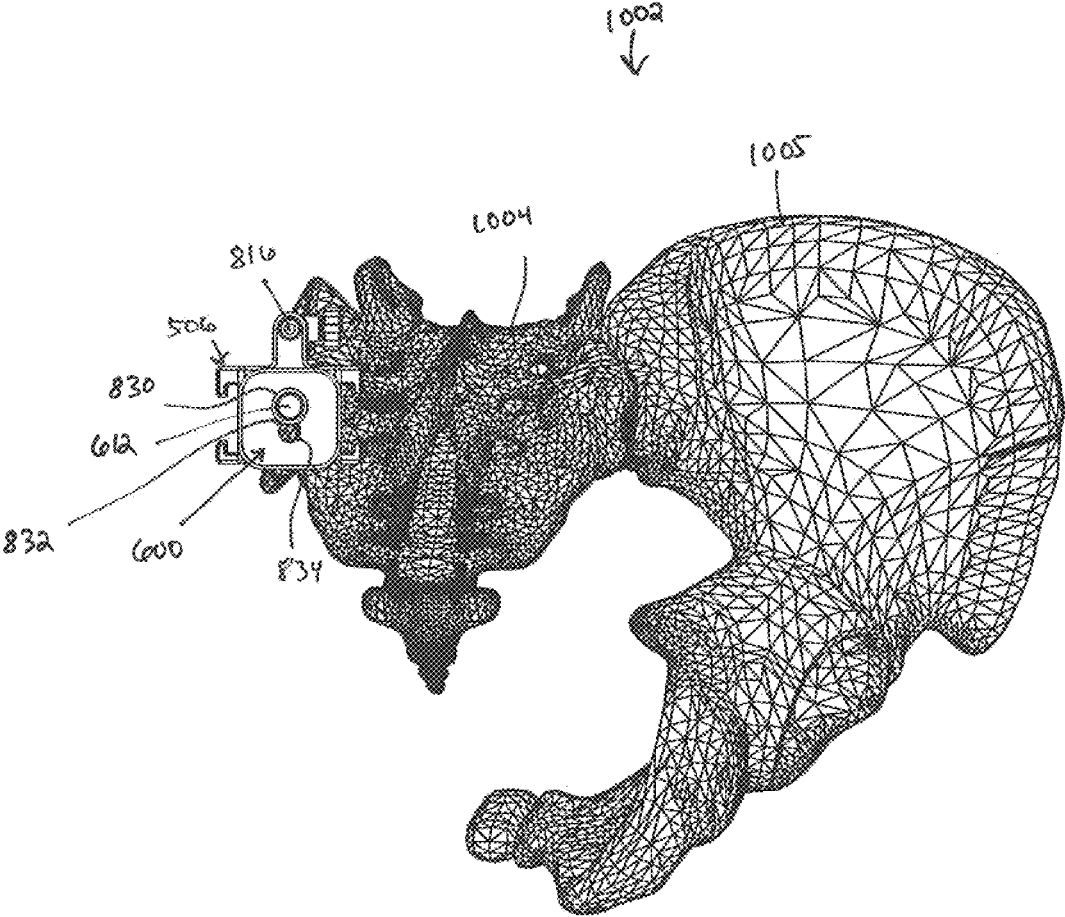

FIG. 85

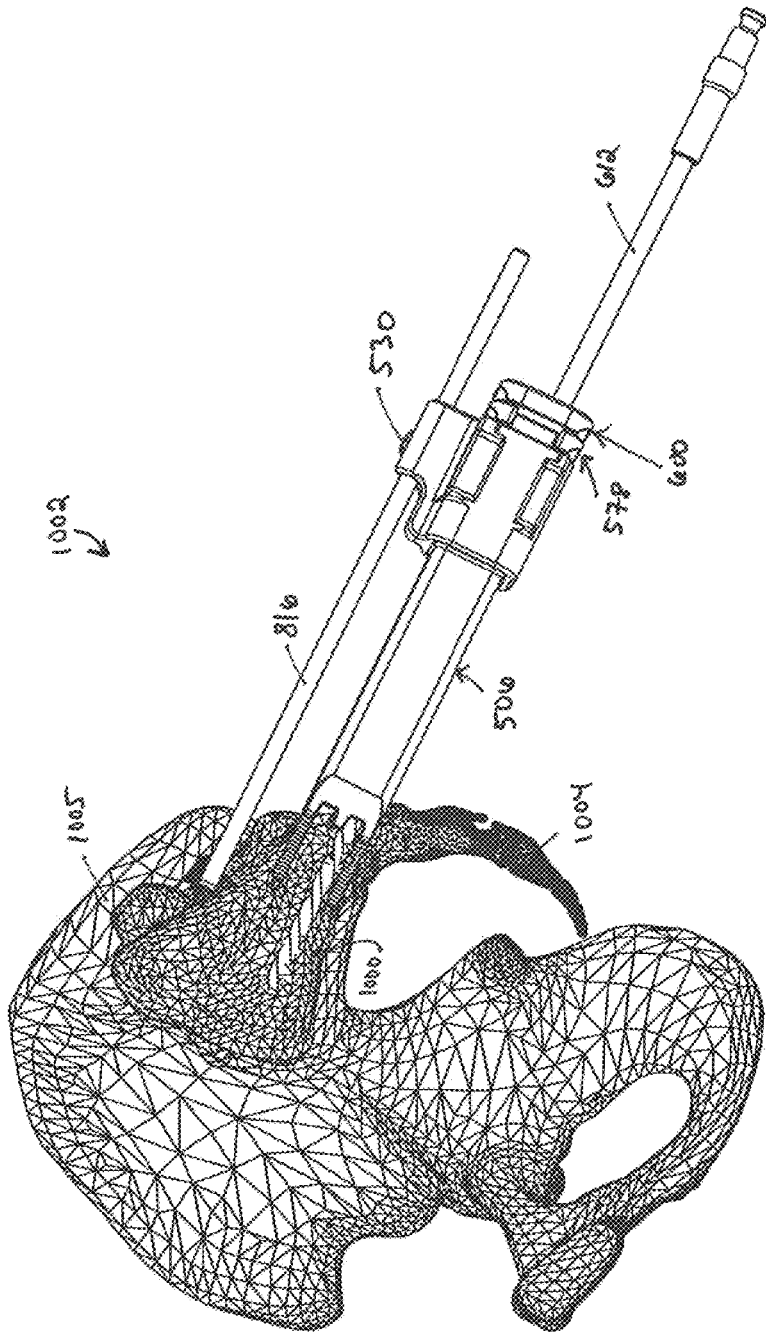

FIG. 86

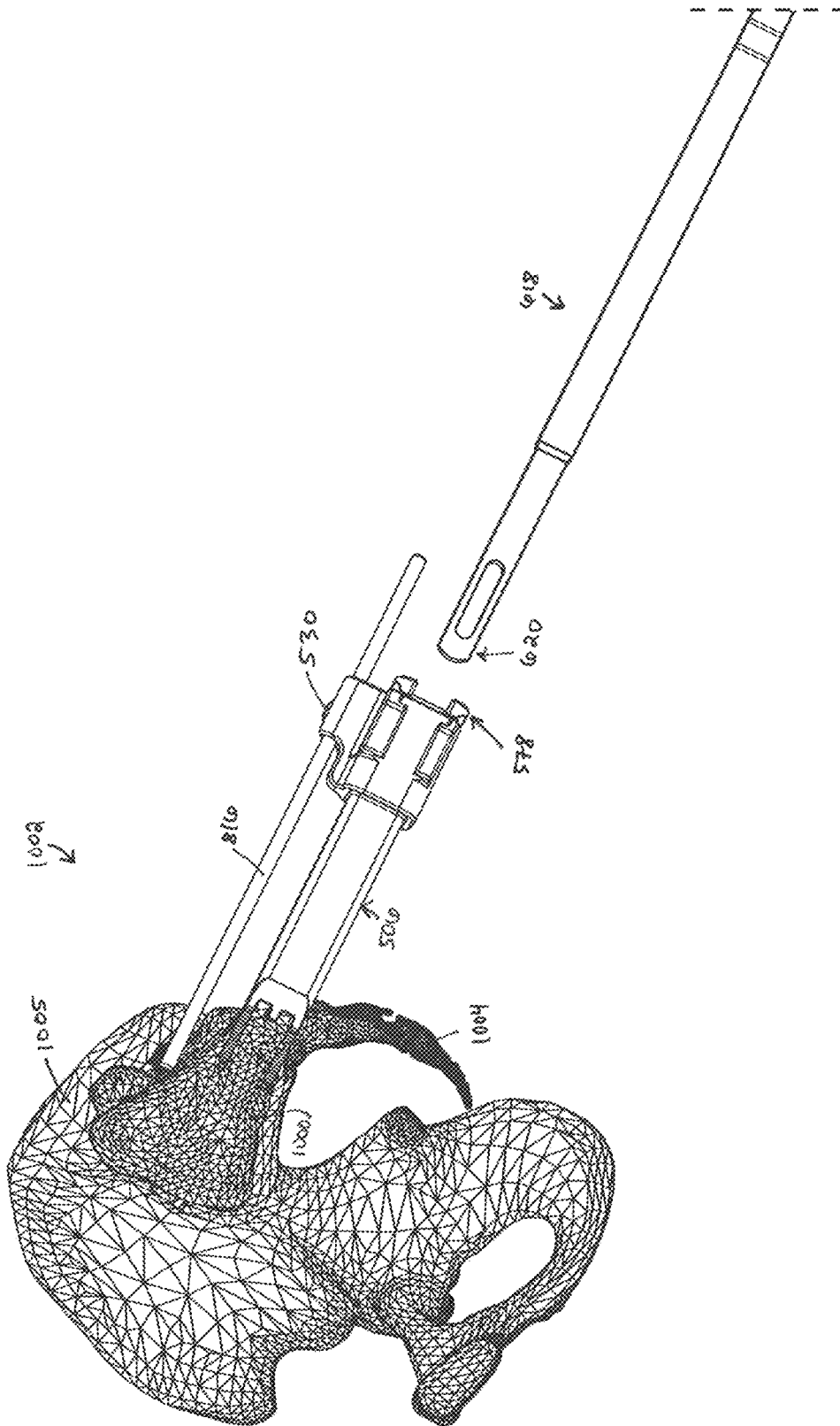

FIG. 87

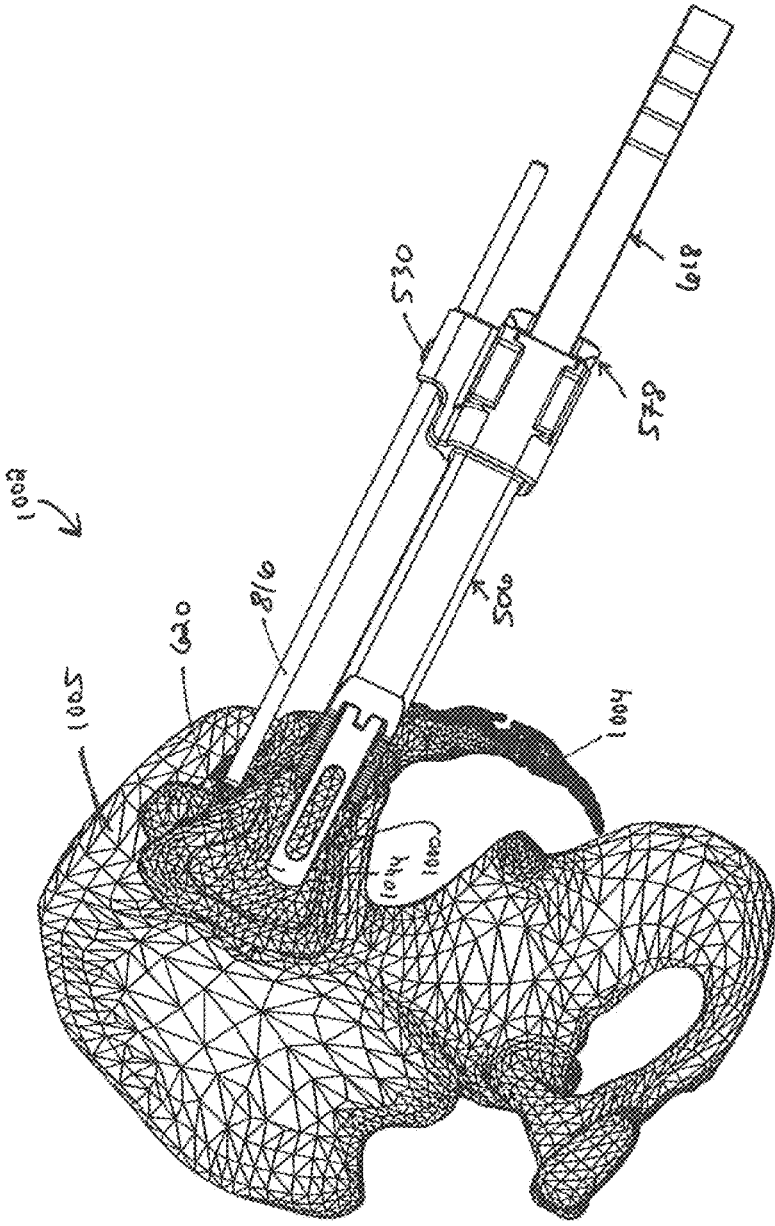

FIG. 88

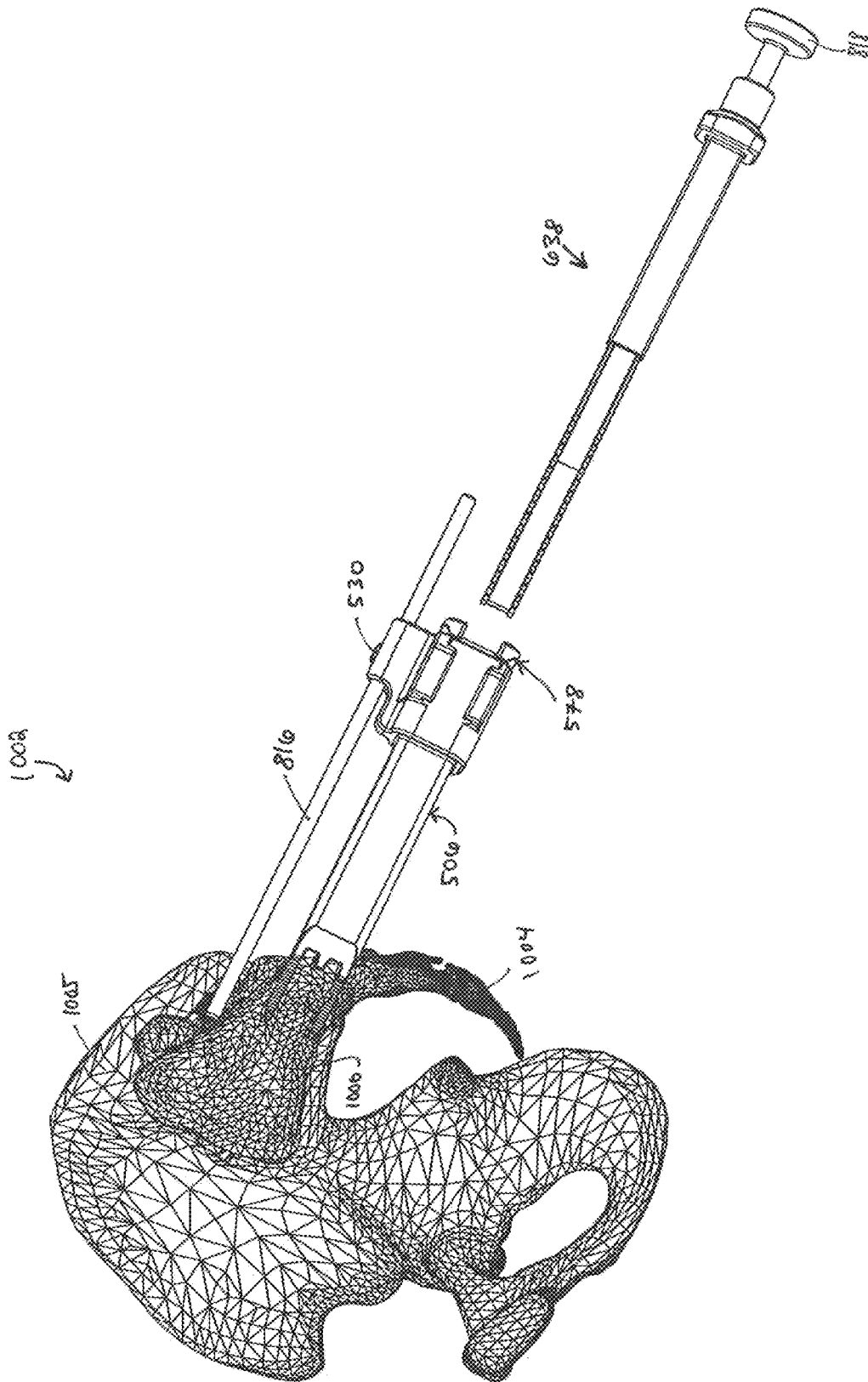

FIG. 89

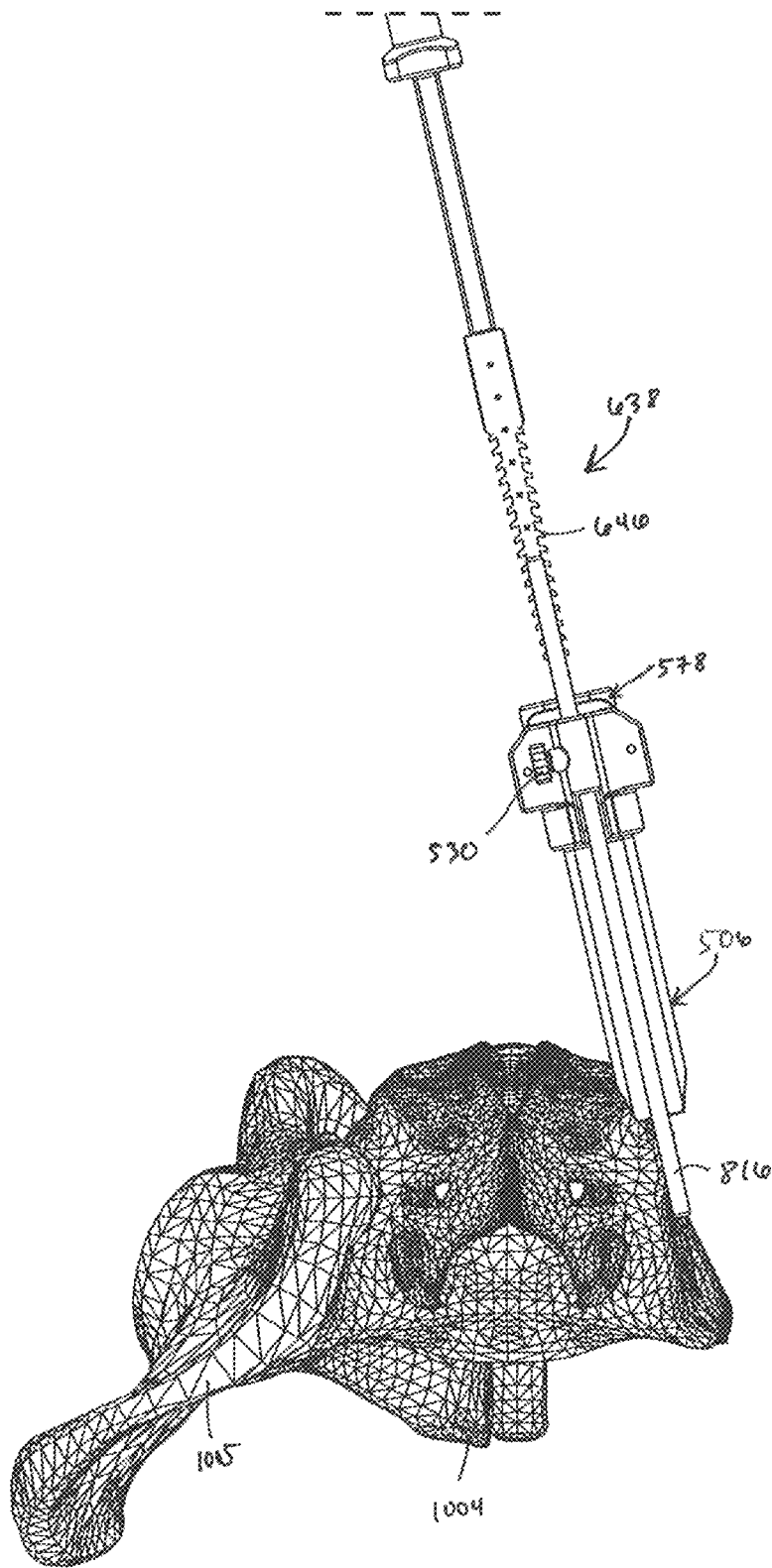

FIG. 90



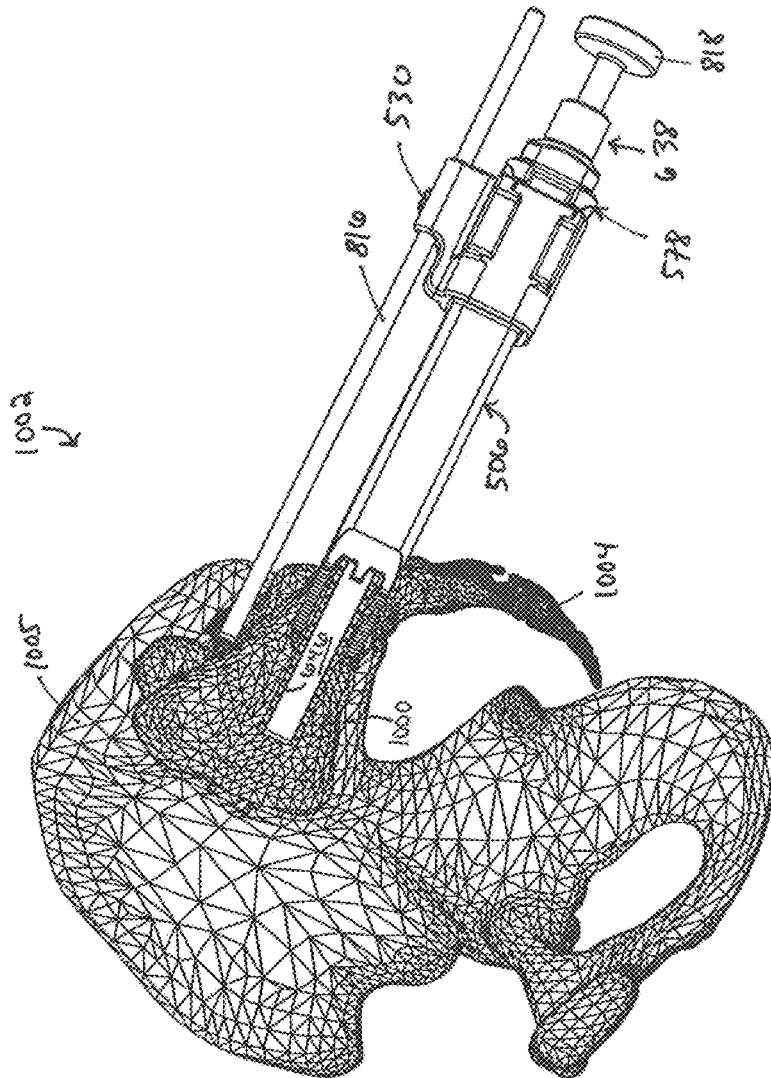

FIG. 91

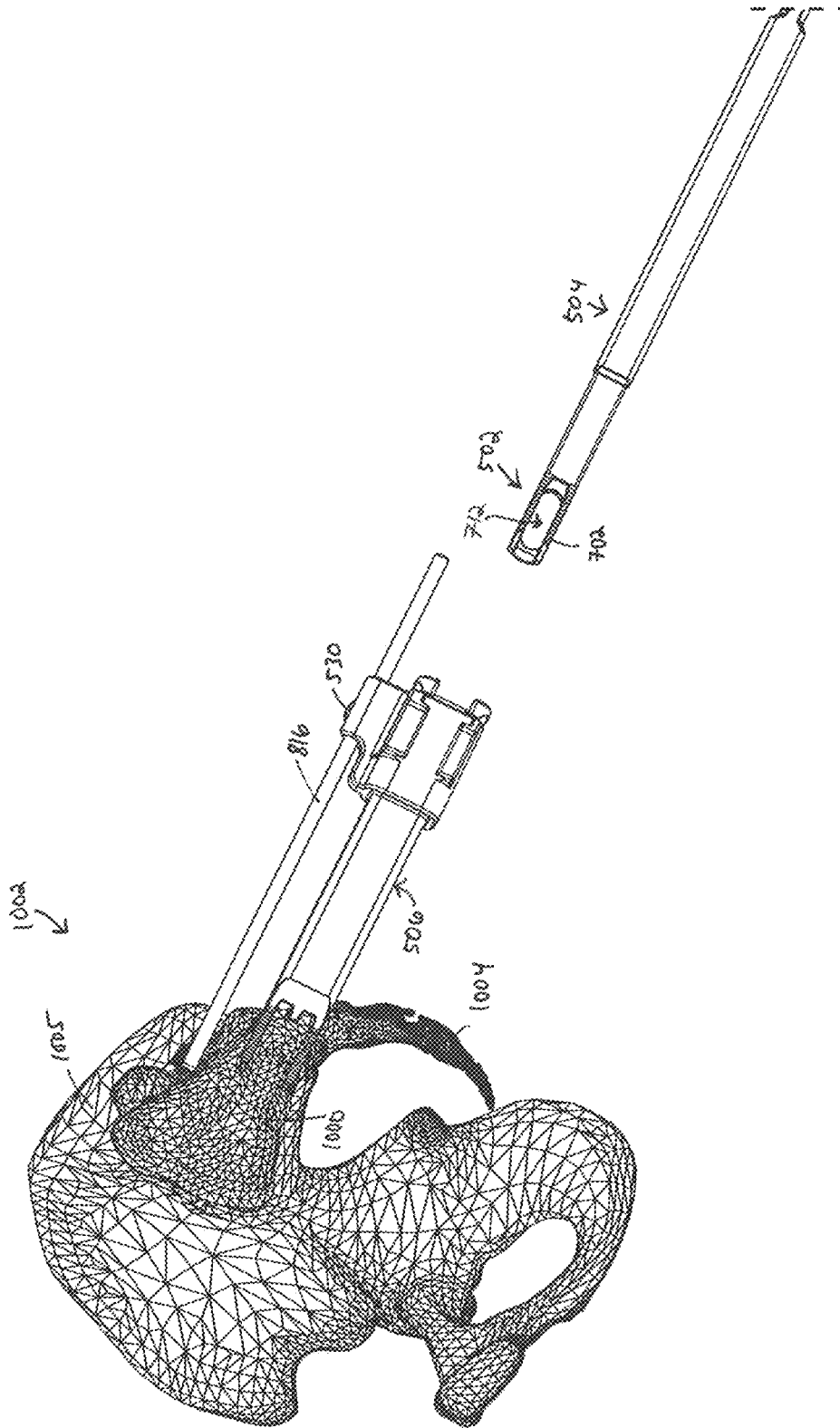

FIG. 92

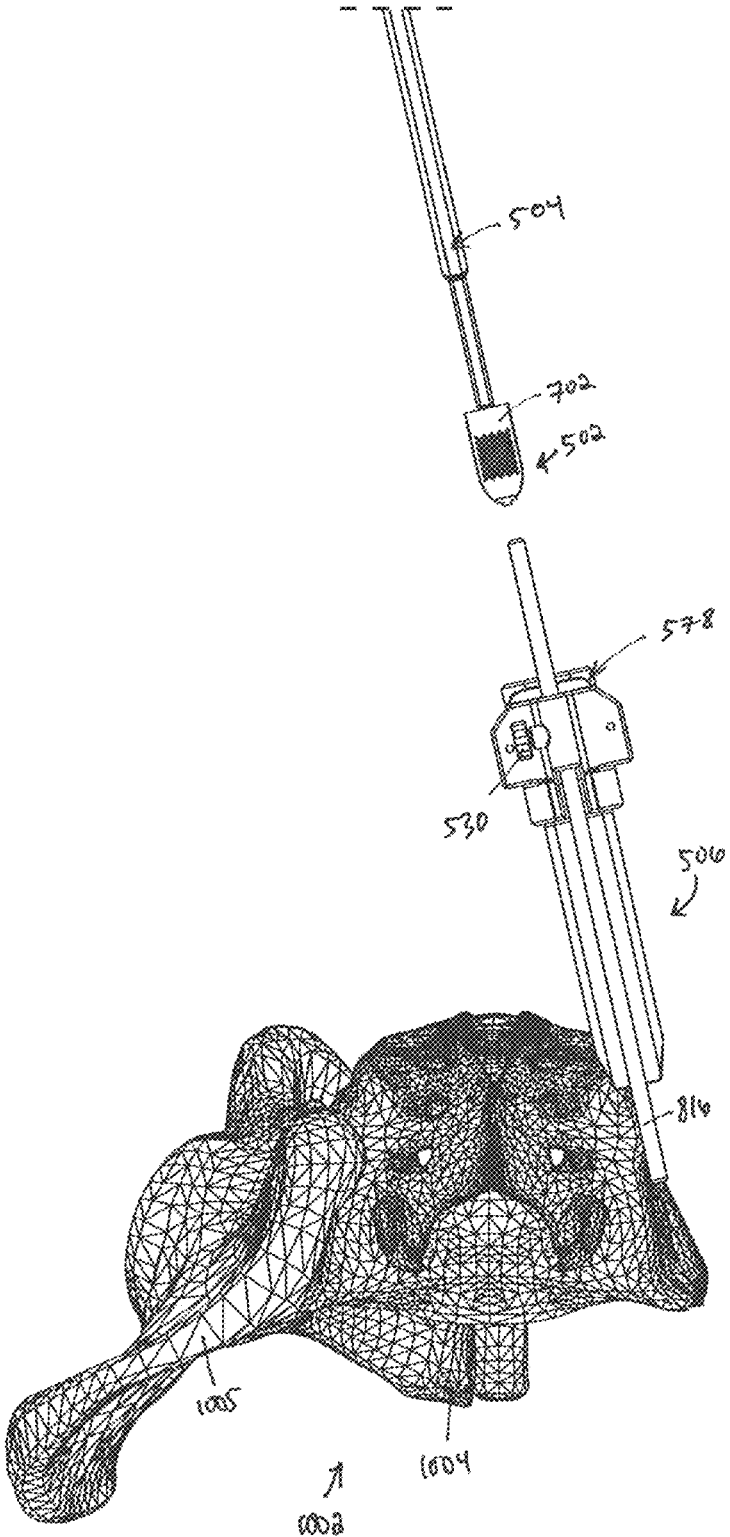

FIG. 93

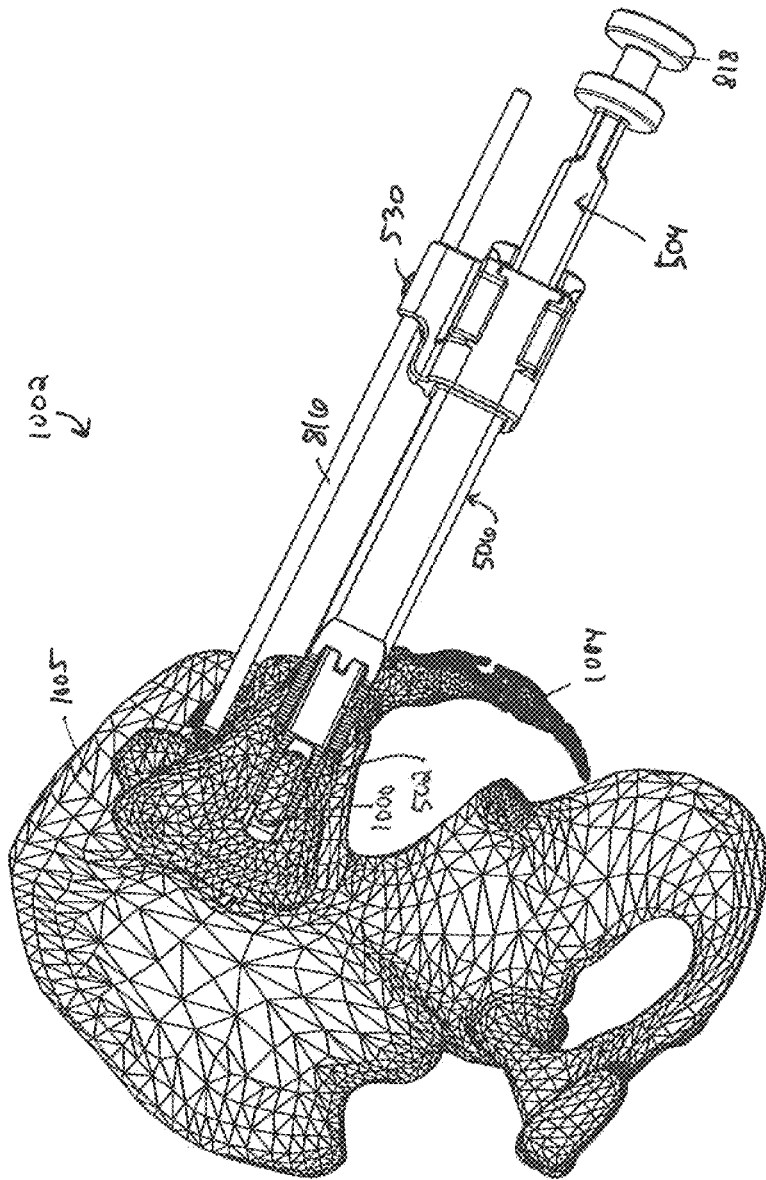

FIG. 94

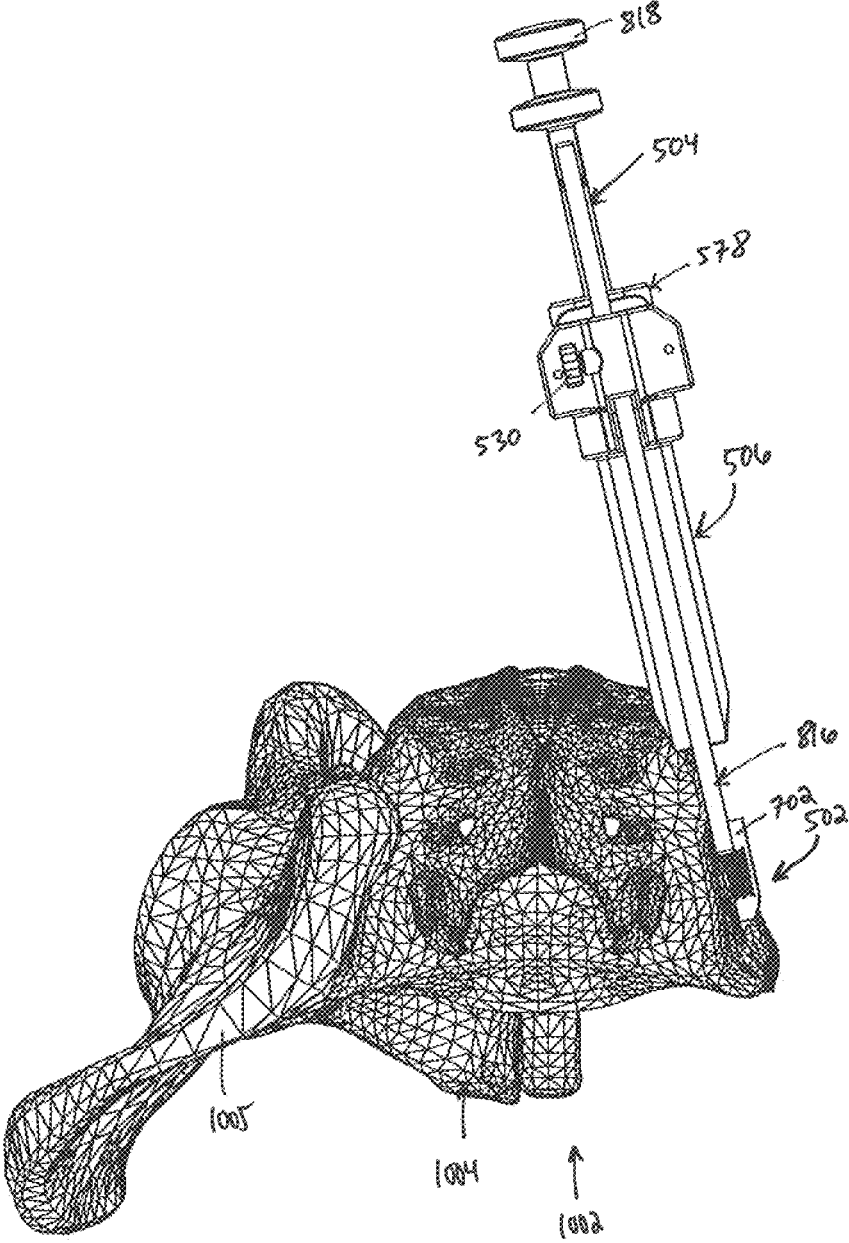

FIG. 95



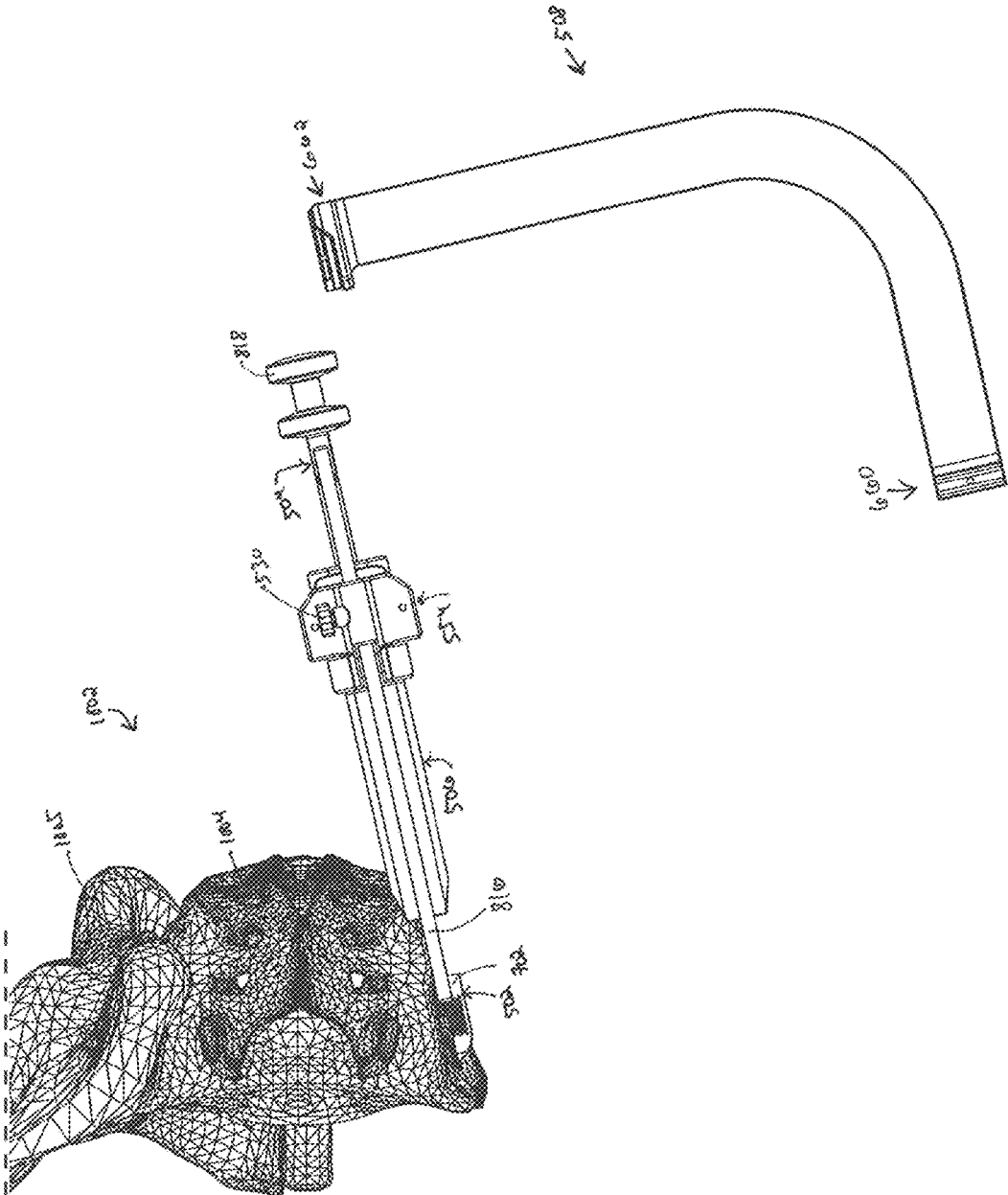

FIG. 97

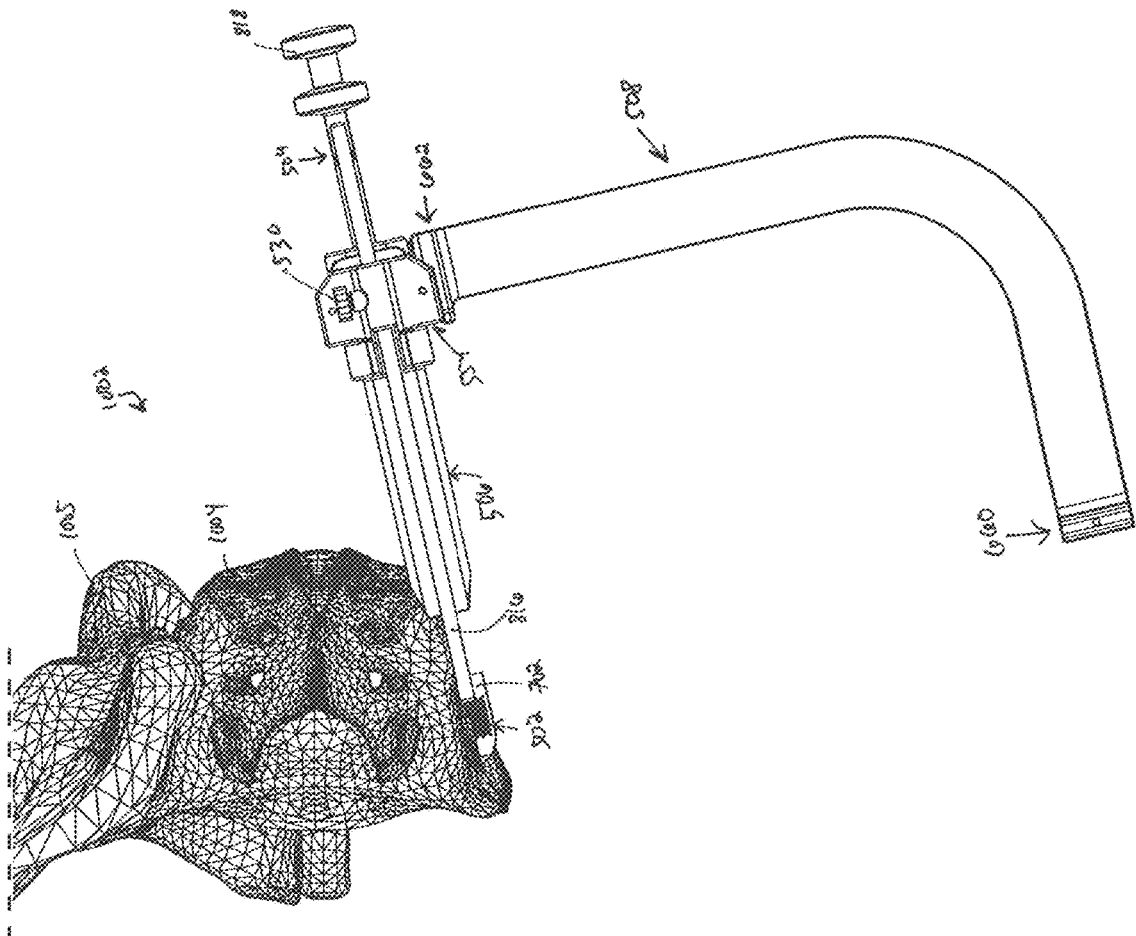

FIG. 98



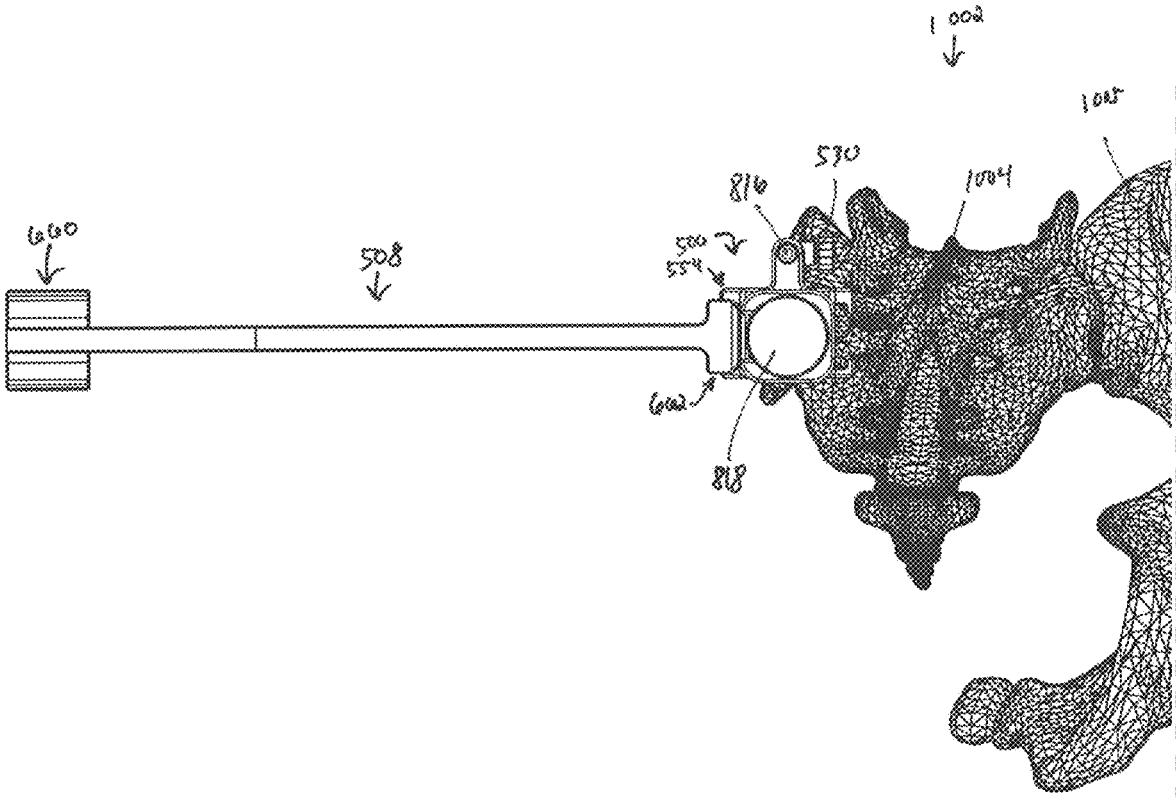

FIG. 99

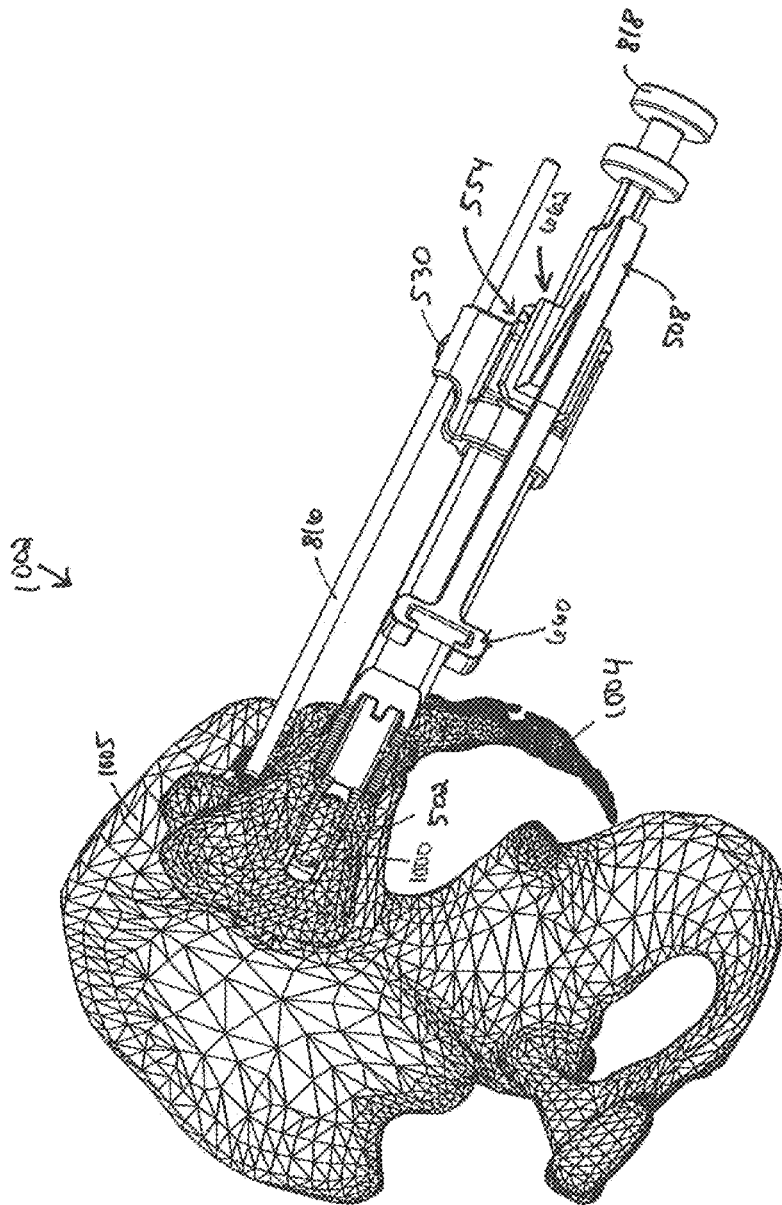

FIG. 100

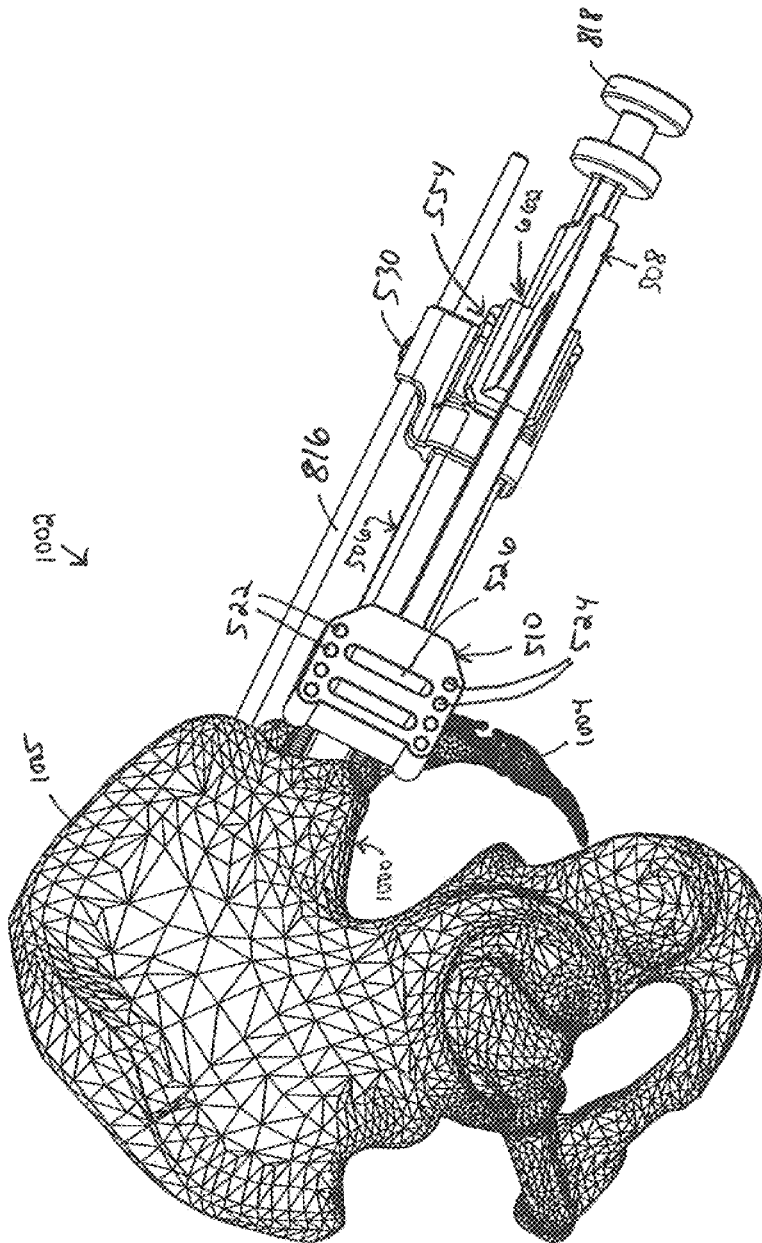

FIG. 101

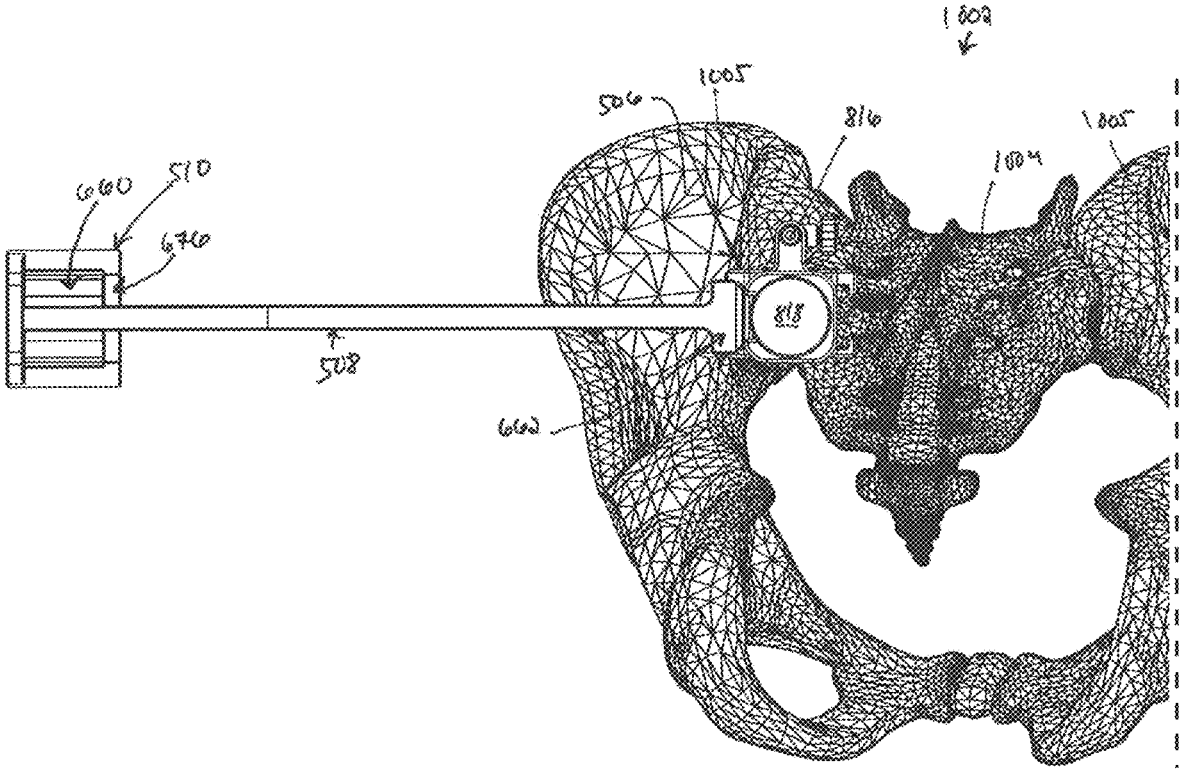

FIG. 102

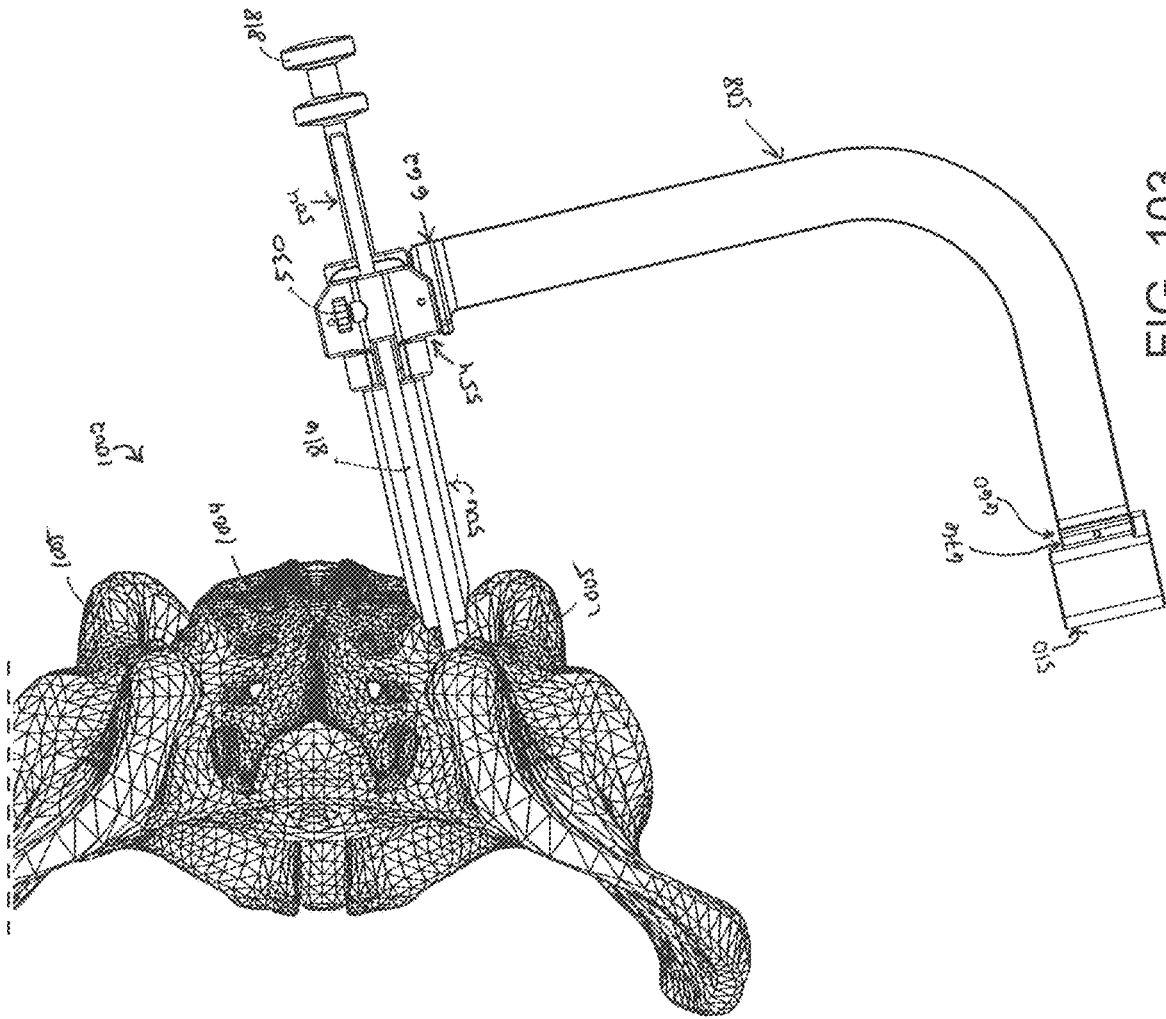

FIG. 103

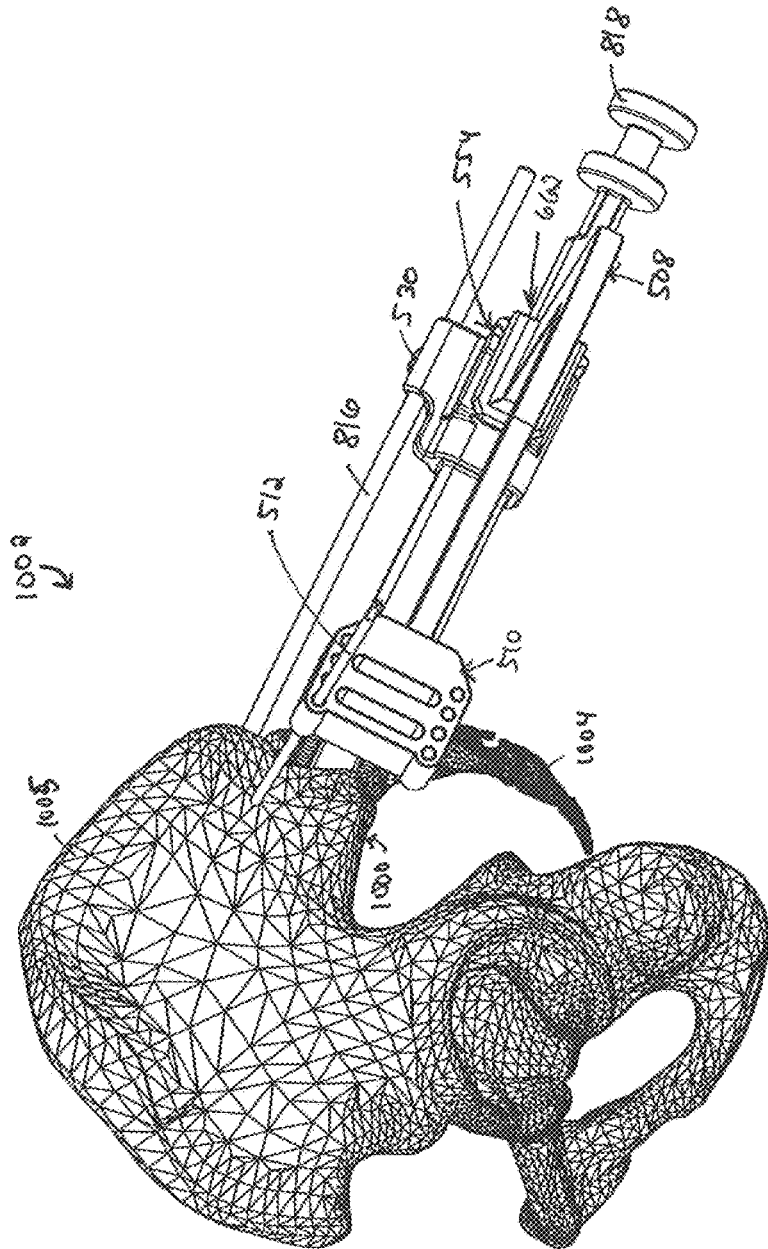

FIG. 104

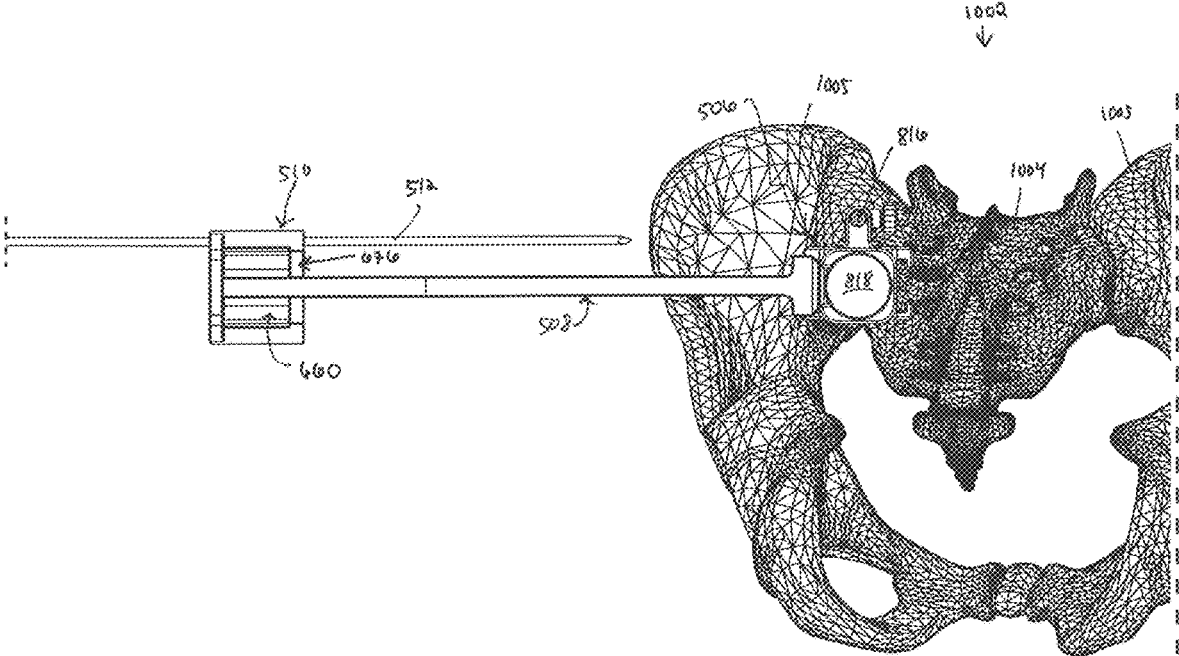

FIG. 105

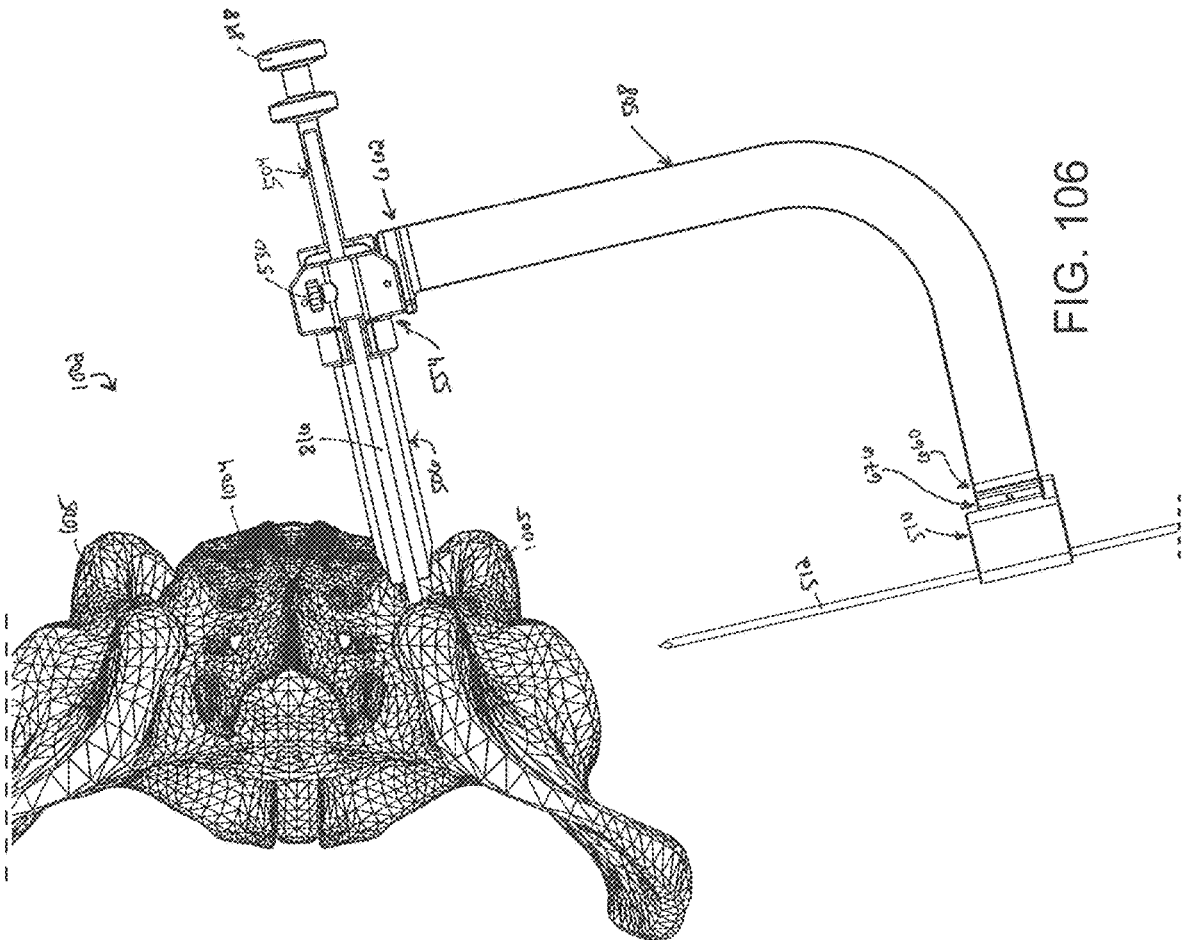

FIG. 106



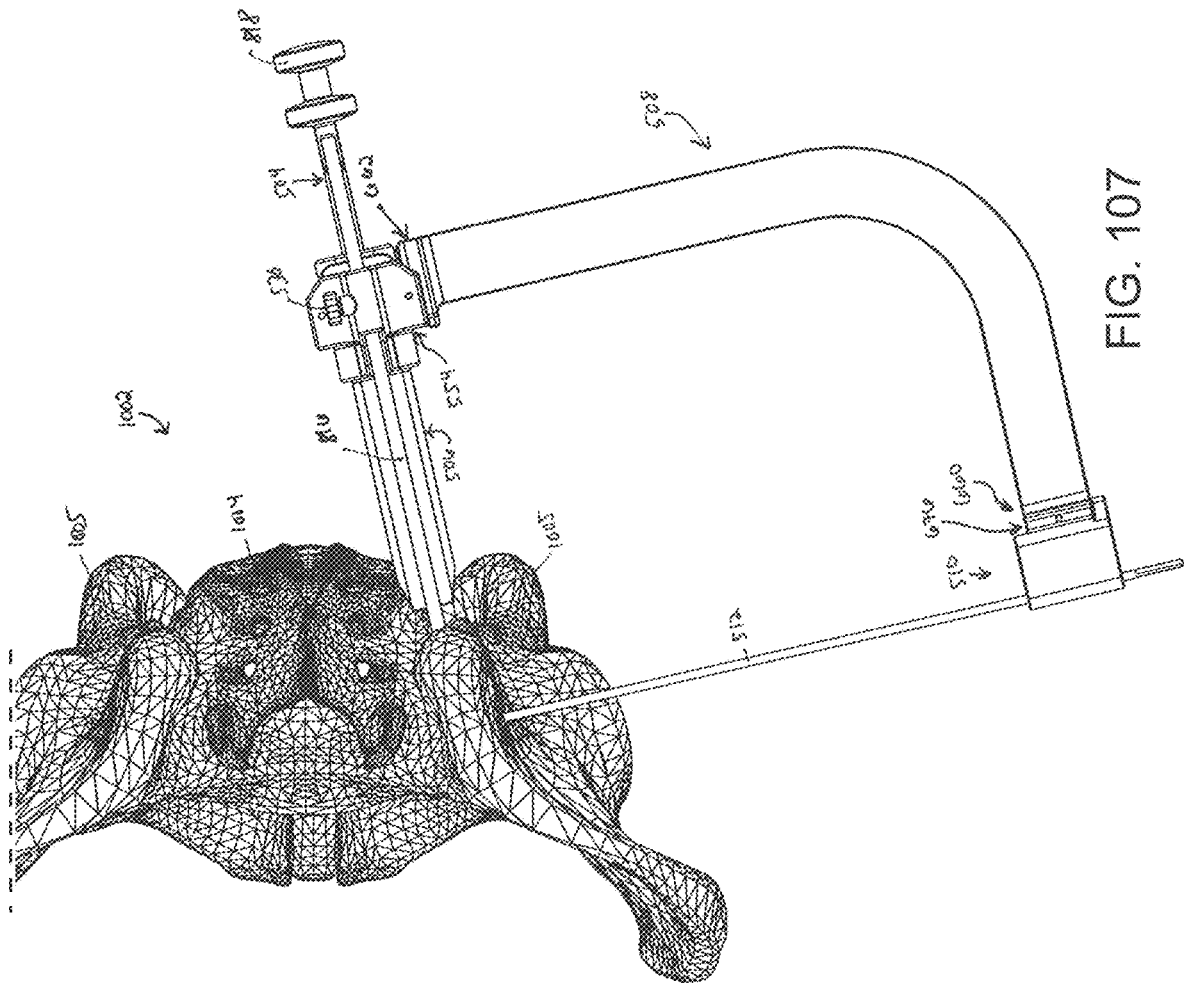

FIG. 107

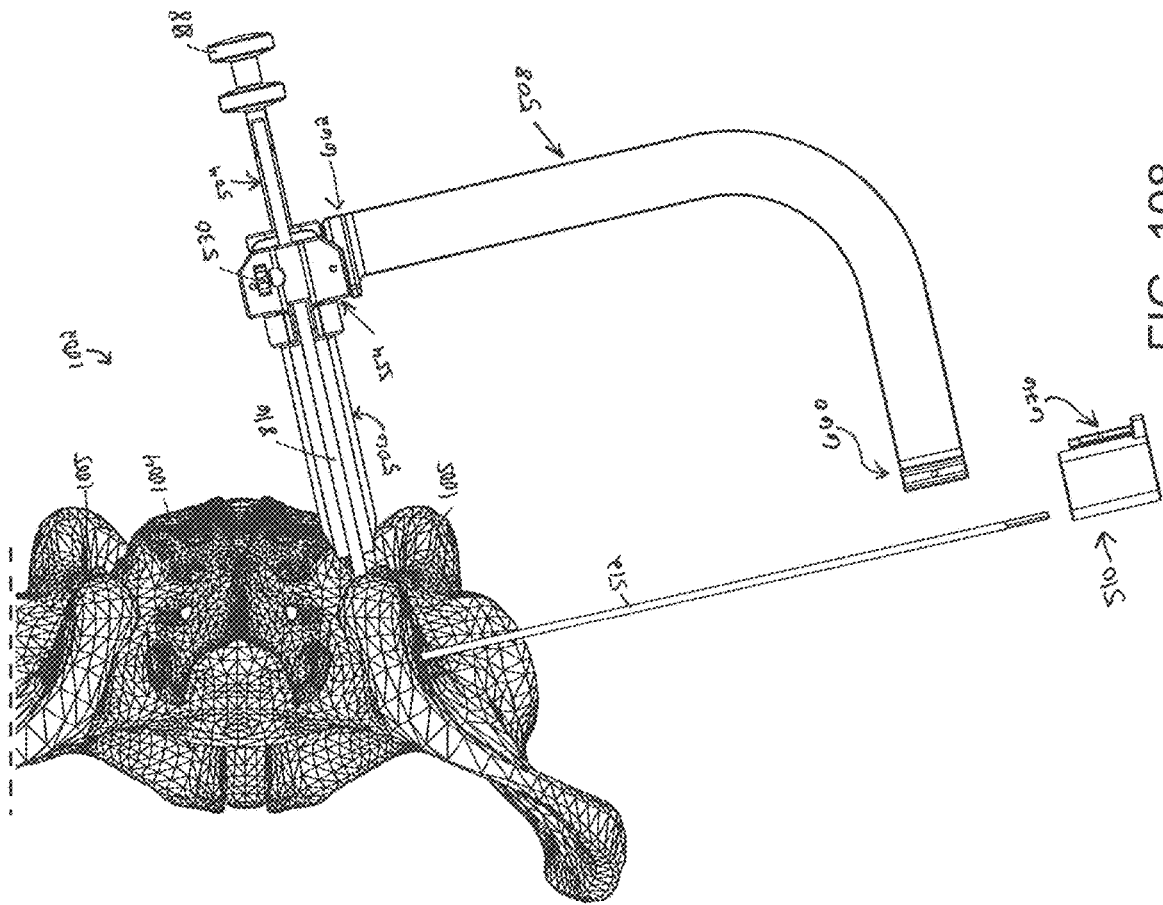

FIG. 108



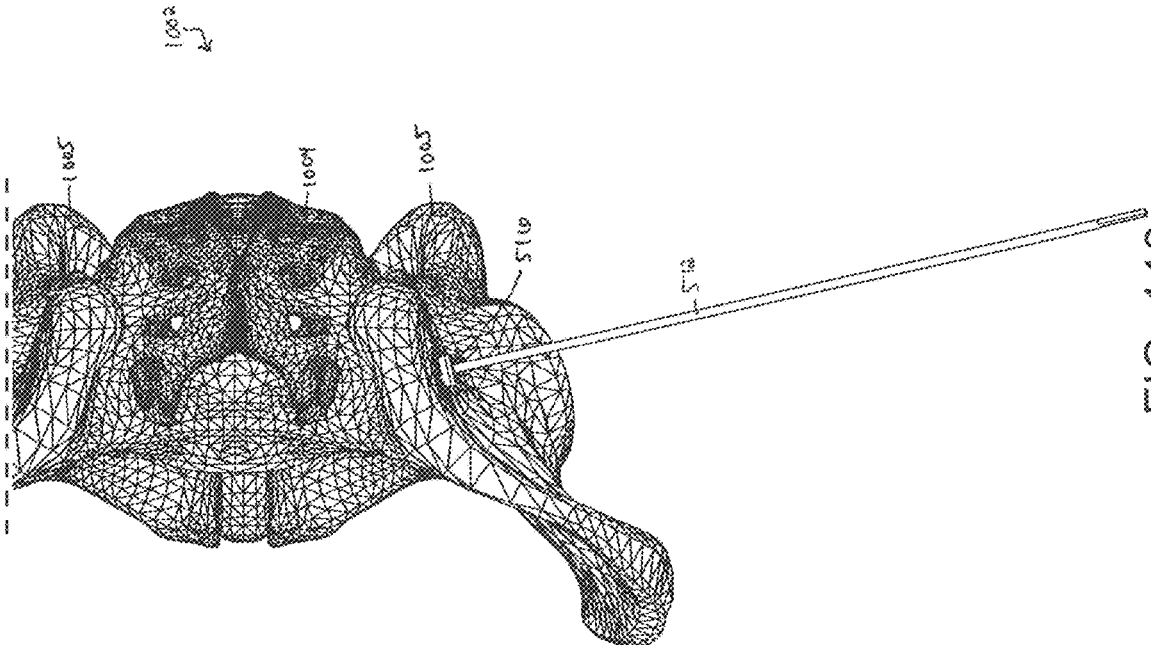

FIG. 110

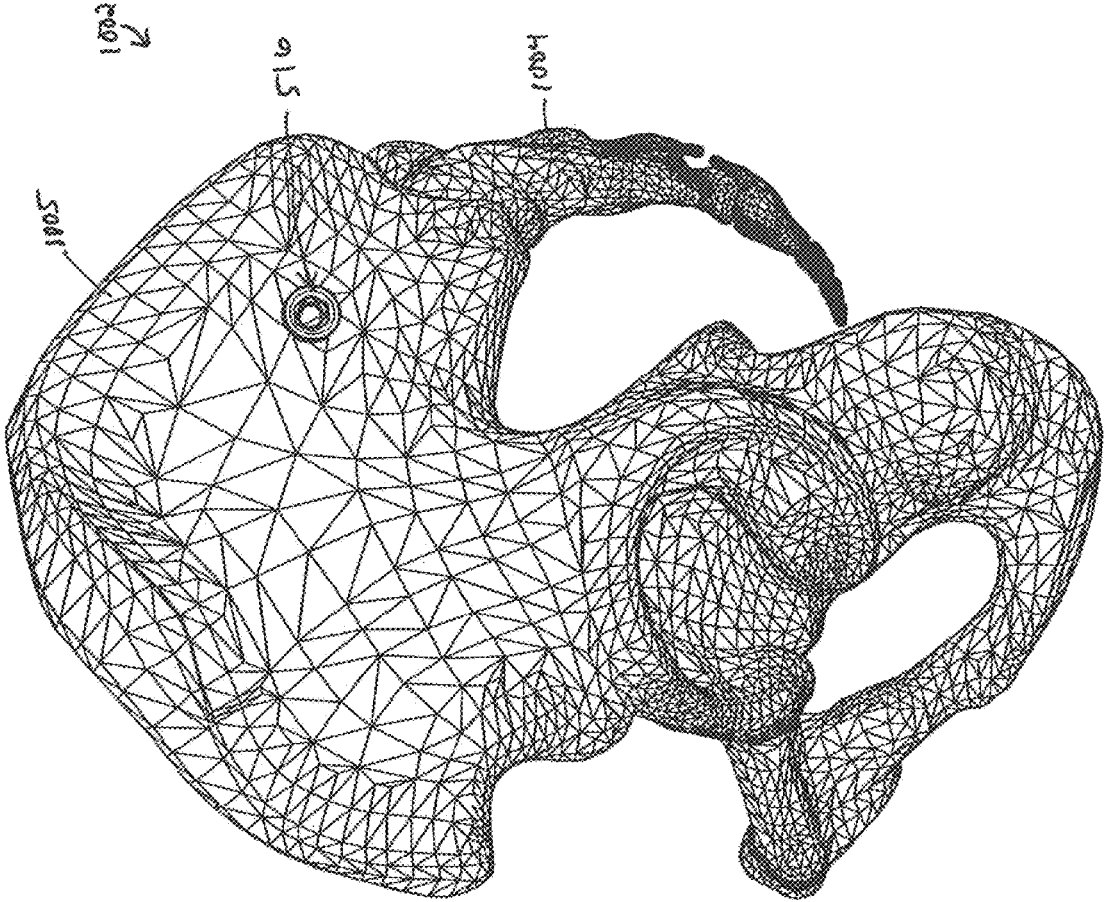

FIG. 111

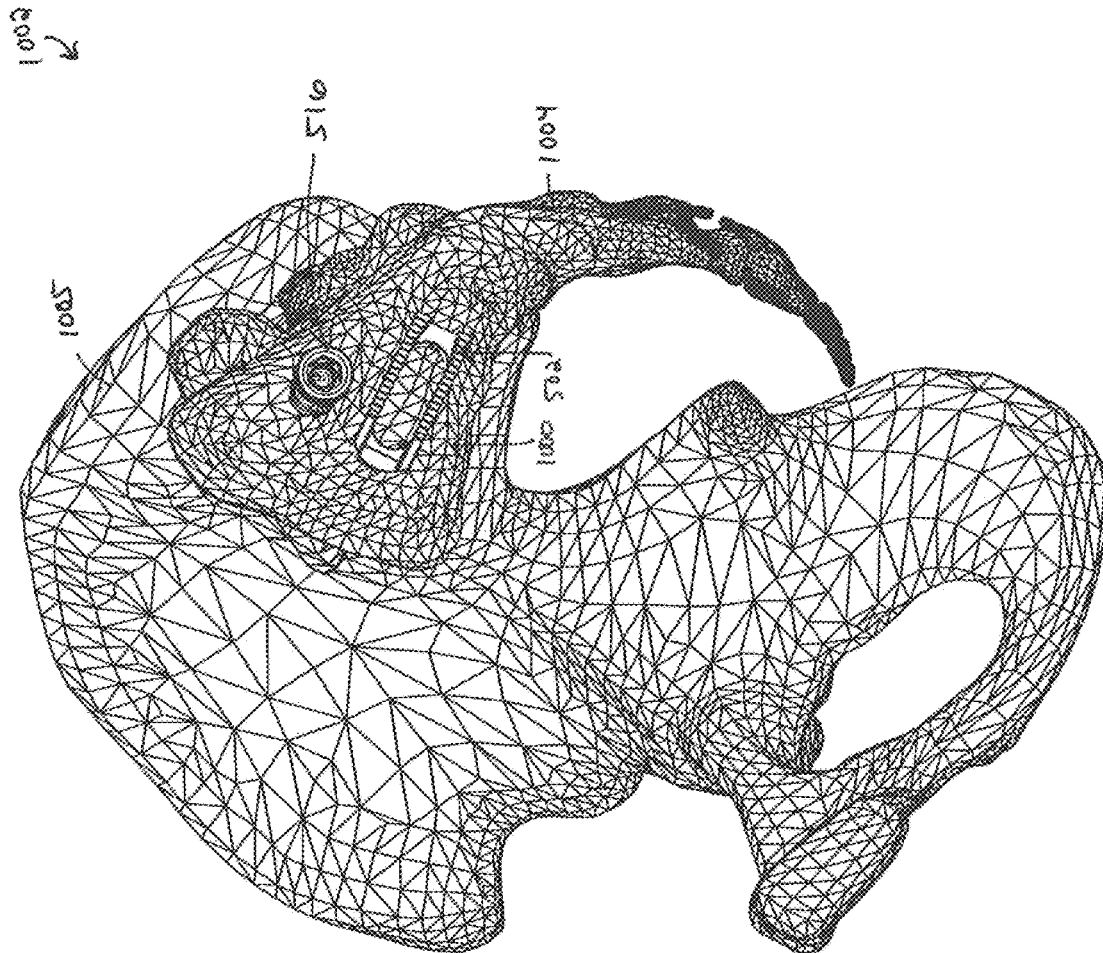

FIG. 112

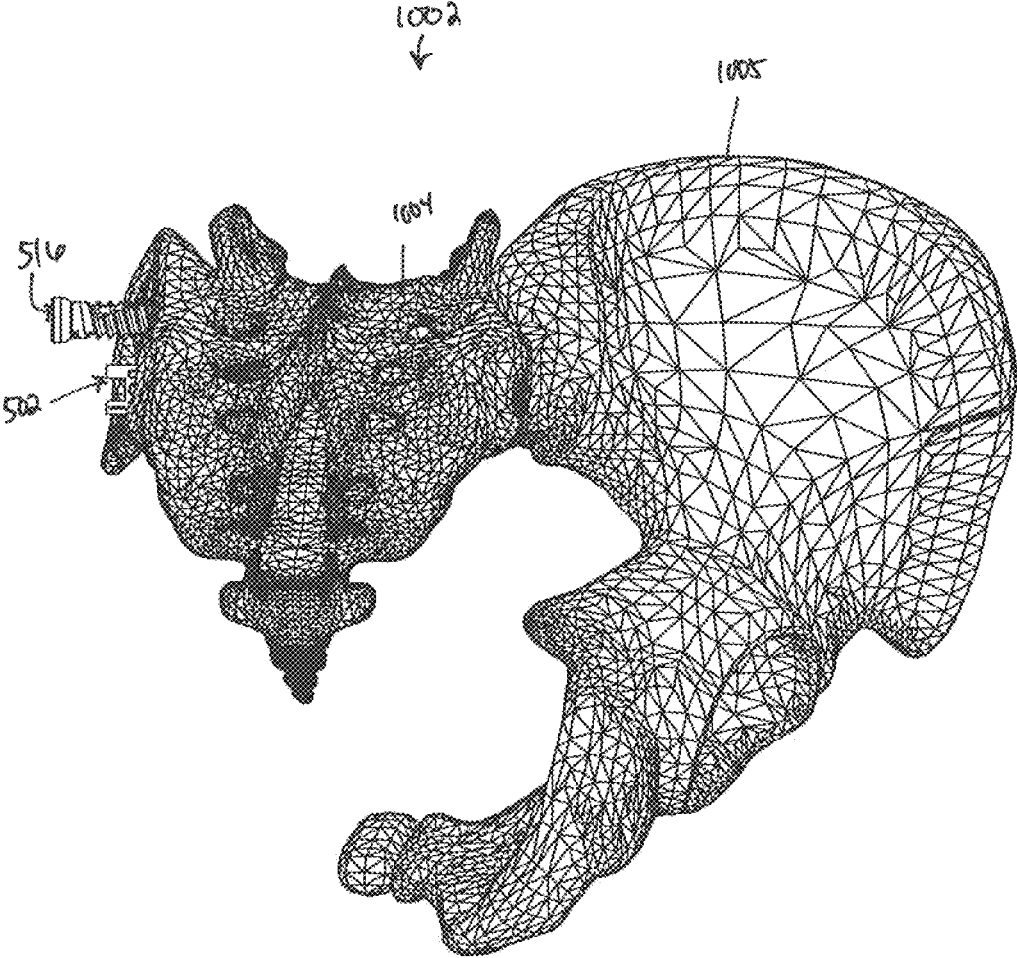

FIG. 113

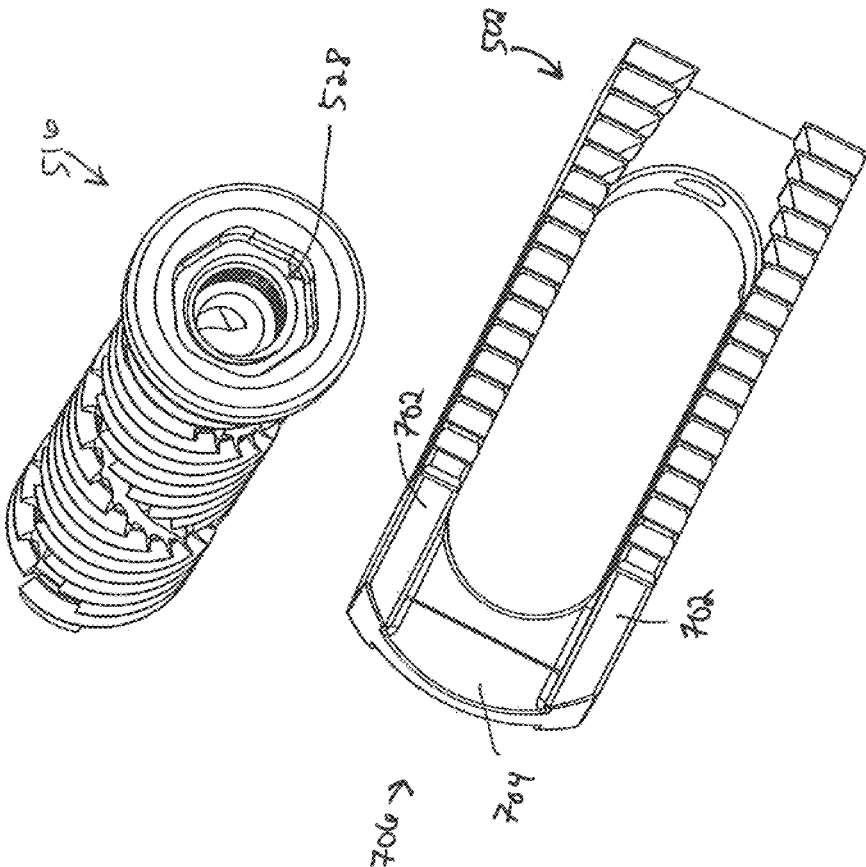

FIG. 114



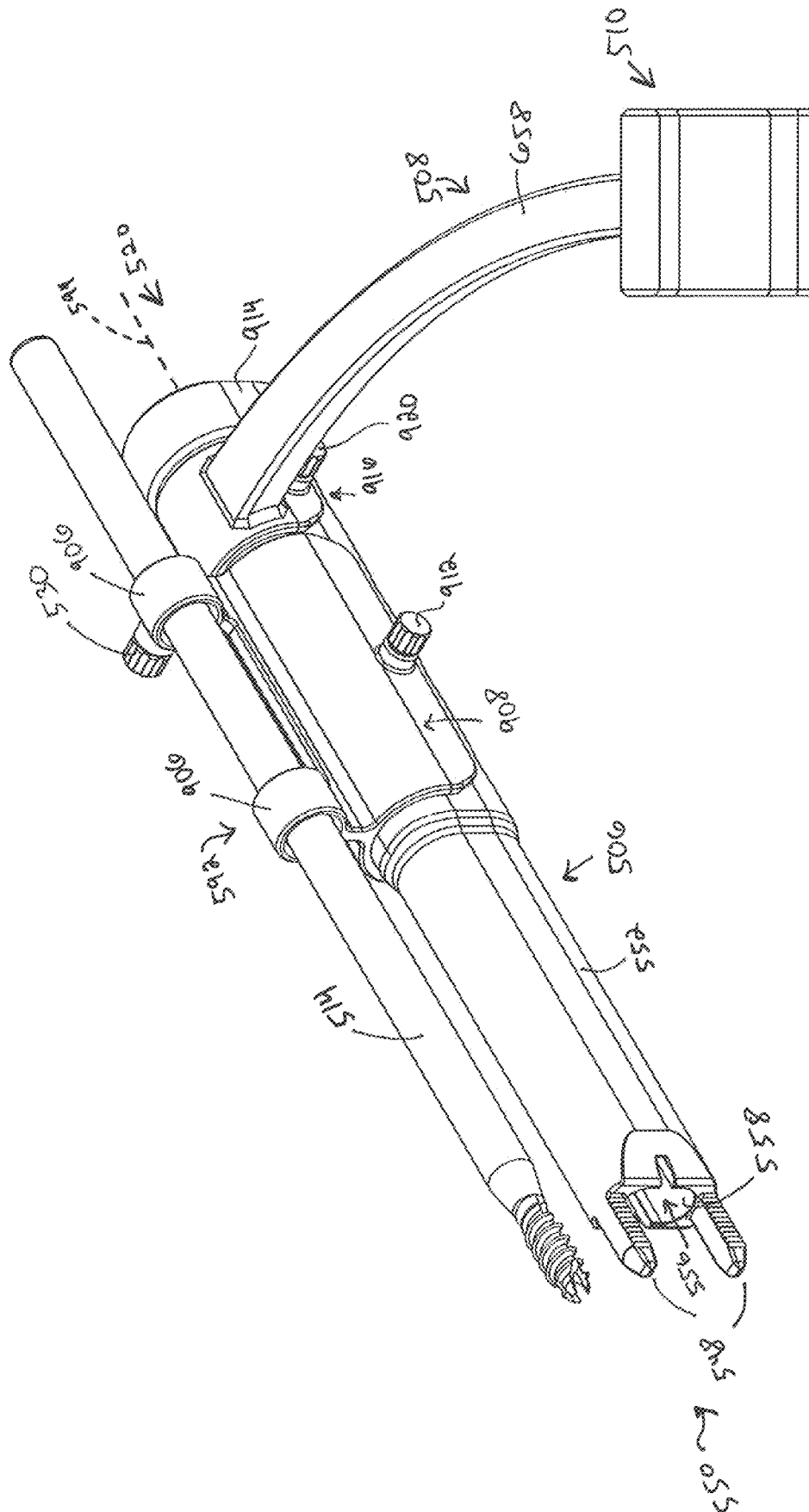
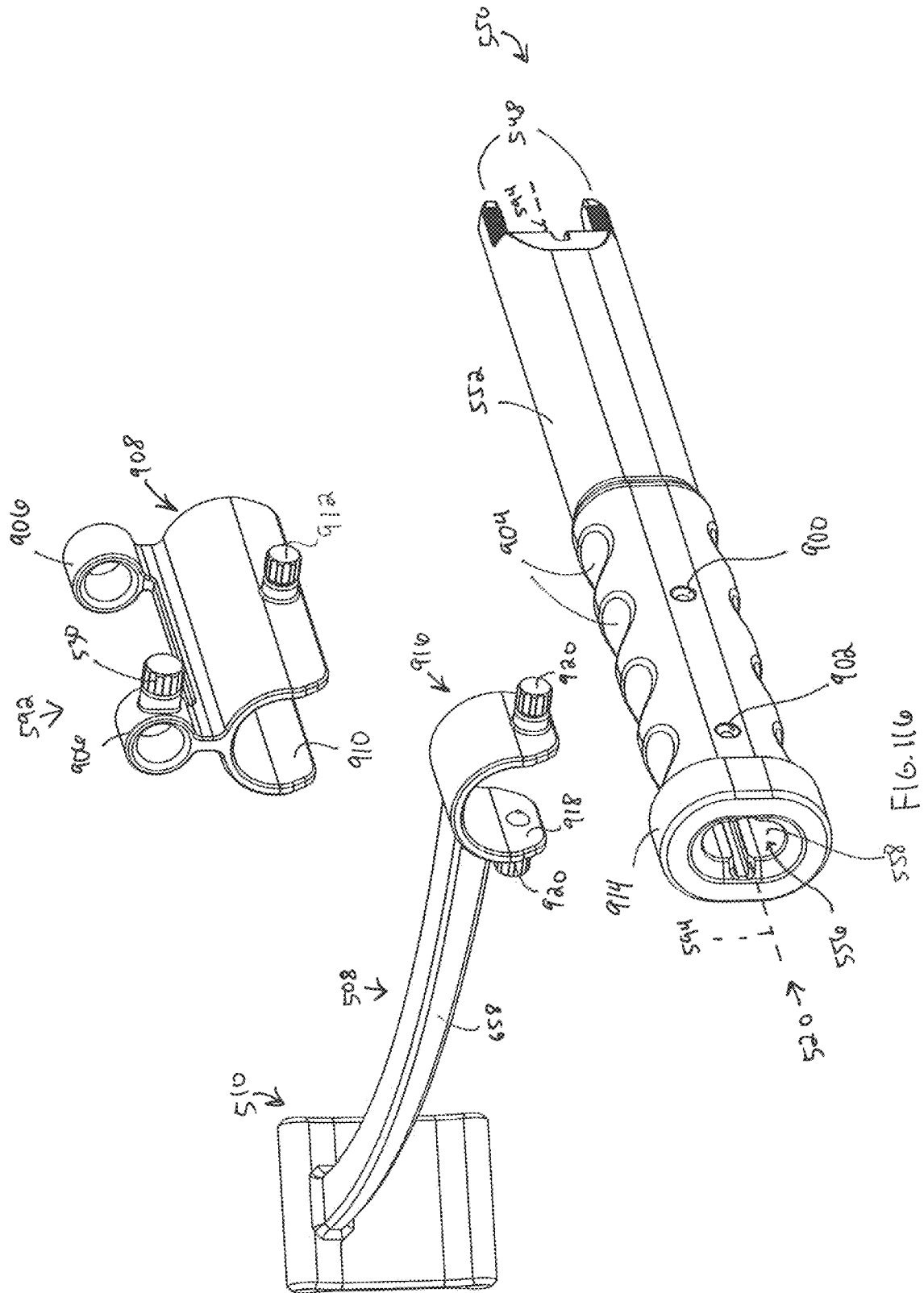
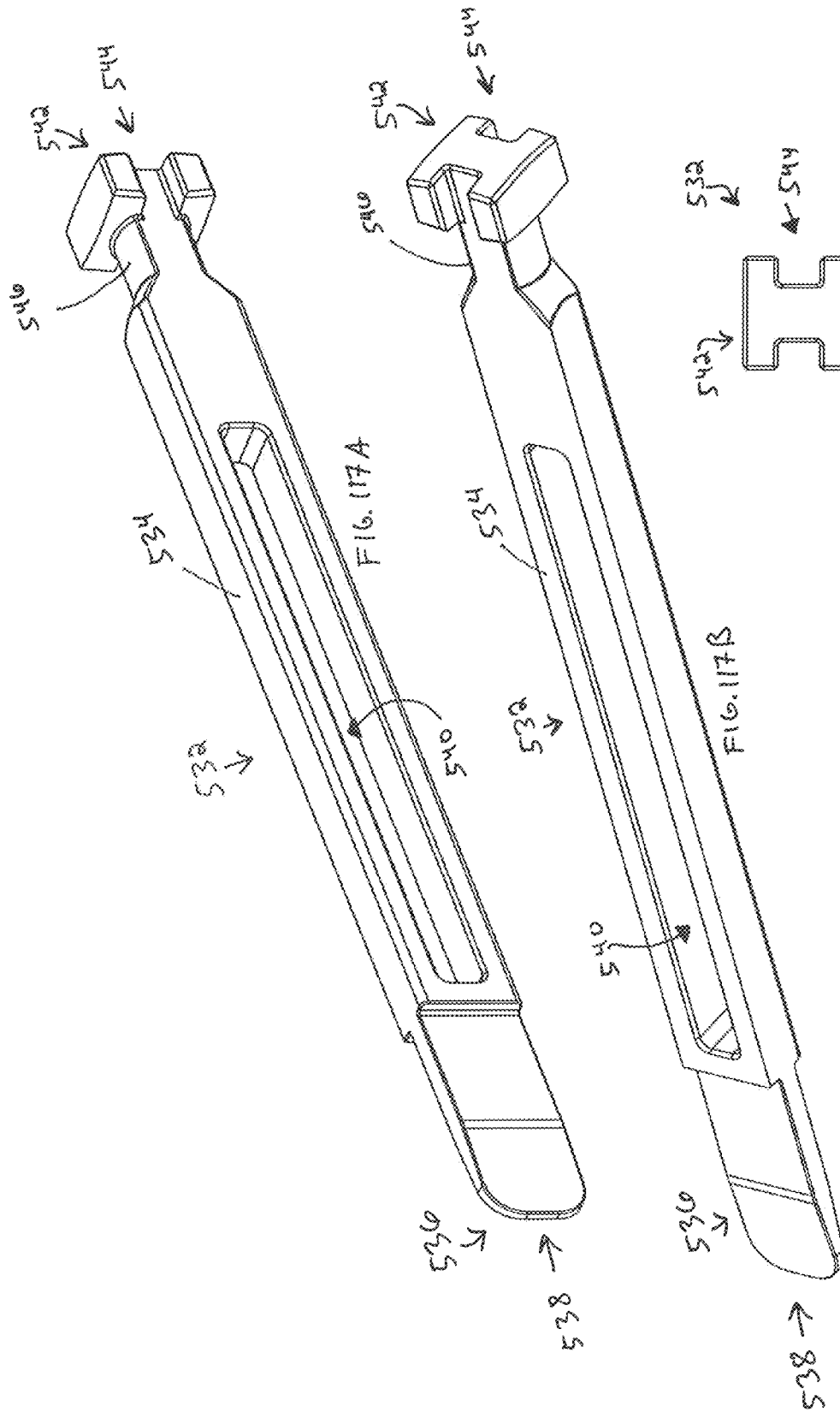

FIG. 115







1

## SYSTEMS FOR AND METHODS OF PREPARING AND FUSING A SACROILIAC JOINT

### CROSS-REFERENCE TO RELATED APPLICATIONS

The present application claims priority under 35 U.S.C. § 119 to U.S. Provisional Patent Application Numbers: 62/559,386 filed Sep. 15, 2017; 62/608,476 filed Dec. 20, 2017; 62/609,095 filed Dec. 21, 2017; 62/632,635 filed Feb. 20, 2018; and 62/640,026 filed Mar. 8, 2018. All of the aforementioned U.S. Provisional Patent Applications are hereby incorporated by reference in their entireties into the present application.

### TECHNICAL FIELD

Aspects of the present disclosure relate to medical apparatus and methods. More specifically, the present disclosure relates to devices and methods for preparing and fusing a sacroiliac joint for fusion.

### BACKGROUND

The sacroiliac joint is the joint between the sacrum and the ilium of the pelvis, which are joined by ligaments. In humans, the sacrum supports the spine and is supported in turn by an ilium on each side. The sacroiliac joint is a synovial joint with articular cartilage and irregular elevations and depressions that produce interlocking of the two bones.

Pain associated with the sacroiliac joint can be caused by traumatic fracture dislocation of the pelvis, degenerative arthritis, sacroiliitis an inflammation or degenerative condition of the sacroiliac joint, osteitis condensans ilii, or other degenerative conditions of the sacroiliac joint. Currently, sacroiliac joint fusion is most commonly advocated as a surgical treatment for these conditions. Fusion of the sacroiliac joint can be accomplished by several different conventional methods. However, while each of these methods has been utilized for fixation and fusion of the sacroiliac joint over the past several decades, substantial problems with respect to the fixation and fusion of the sacroiliac joint remain unresolved.

A significant problem with certain conventional methods for fixation and fusion of the sacroiliac joint may be that the surgeon has to make a substantial incision in the skin and tissues for direct access to the sacroiliac joint involved. These invasive approaches allow the sacroiliac joint to be seen and touched directly by the surgeon. Often referred to as an “open surgery”, these procedures have the attendant disadvantages of requiring general anesthesia and can involve increased operative time, hospitalization, pain, and recovery time due to the extensive soft tissue damage resulting from the open surgery.

A danger to open surgery using an anterior approach can be damage to the L5 nerve root, which lies approximately two centimeters medial to the sacroiliac joint or damage to the major blood vessels. Additionally and as seen in FIG. 1, which depicts a conventional fusion procedure (immobilization of the articular surfaces of the sacroiliac joint in relation to one another) on a sacroiliac joint 1, one or more screws or implants 2 are implanted transversely across the articular surfaces 3 and through the sacrum 4 and the ilium bones 5. That is, the joint 1 is immobilized by placement of

2

a fusion device 2 transverse to or across a plane defined by articular surfaces 3 of the sacroiliac joint space.

Use of trans-sacroiliac and S1 pedicle-iliac bone implants can also involve the risk of damage to the lumbosacral neurovascular elements. Damage to the lumbosacral neurovascular elements as well as delayed union or non-union of the sacroiliac joint by use of these procedures may require revision surgery to remove all or a portion of the implants or repeat surgery as to these complications.

Another significant problem with conventional procedures utilizing minimally invasive small opening procedures can be that the procedures are technically difficult, requiring biplanar fluoroscopy of the articular surfaces of the sacroiliac joint and extensive surgical training and experience. Despite the level of surgical training and experience, there is a substantial incidence of damage to the lumbosacral neurovascular elements. Additionally, sacral anomalies can further lead to mal-placement of implants leading to damage of surrounding structures. Additionally, these procedures are often performed without fusion of the sacroiliac joint, which does not remove the degenerative joint surface and thereby does not address the degenerative condition of the sacroiliac joint, which may lead to continued or recurrent sacroiliac joint pain.

Another significant problem with conventional procedures can be the utilization of multiple trans-sacroiliac elongate implants, which do not include a threaded surface. This approach requires the creation of trans-sacroiliac bores in the pelvis and nearby sacral foramen, which can be of relatively large dimension and which are subsequently broached with instruments, which can result in bone being impacted into the pelvis and neuroforamen.

The creation of the trans-sacroiliac bores and subsequent broaching of the bores requires a guide pin, which may be inadvertently advanced into the pelvis or sacral foramen, resulting in damage to other structures. Additionally, producing the trans-sacroiliac bores, broaching, or placement of the elongate implants may result in damage to the lumbosacral neurovascular elements, as above discussed. Additionally, there may be no actual fusion of the articular portion of the sacroiliac joint, which may result in continued or recurrent pain requiring additional surgery.

Another substantial problem with conventional procedures can be that placement of posterior extra-articular distracting fusion implants and bone grafts may be inadequate with respect to removal of the articular surface or preparation of cortical bone, the implant structure and fixation of the sacroiliac joint. The conventional procedures may not remove sufficient amounts of the articular surfaces or cortical surfaces of the sacroiliac joint to relieve pain in the sacroiliac joint. The conventional implant structures may have insufficient or avoid engagement with the articular surfaces or cortical bone of the sacroiliac joint for adequate fixation or fusion. The failure to sufficiently stabilize and fuse the sacroiliac joint with the conventional implant structures and methods may result in a failure to relieve the condition of sacroiliac joint being treated. Additionally, conventional methods of driving apart a sacrum and ilium may lead to mal-alignment of the sacroiliac joint and increased pain.

Improvements to sacroiliac joint fusion involve systems and methods for non-transverse delivery of an implant into the sacroiliac joint are described in U.S. Patent Applications: Ser. No. 12/998,712, filed May 23, 2011 entitled SACROILIAC JOINT FIXATION FUSION SYSTEM; Ser. No. 13/236,411, filed Sep. 19, 2011 entitled SYSTEMS FOR AND METHODS OF FUSING A SACROILIAC JOINT;

and Ser. No. 13/475,695, filed May 18, 2012, entitled SYSTEMS FOR AND METHODS OF FUSING A SACROILIAC JOINT; and Ser. No. 13/945,053, filed Jul. 18, 2013, entitled SYSTEMS FOR AND METHODS OF FUSING A SACROILIAC JOINT; and Ser. No. 13/946,790, filed Jul. 19, 2013, entitled SYSTEMS FOR AND METHODS OF FUSING A SACROILIAC JOINT; and Ser. No. 14/216,975, filed Mar. 17, 2014, entitled SYSTEMS AND METHODS FOR FUSING A SACROILIAC JOINT AND ANCHORING AN ORTHOPEDIC APPLIANCE; and Ser. No. 14/447,612, filed Jul. 31, 2014, entitled SYSTEMS FOR AND METHODS OF FUSING A SACROILIAC JOINT. All of application Ser. Nos. 12/998,712, 13/236,411, 13/475,695, 13/945,053, 13/946,790, 14/216,975, and 14/447,612 are herein incorporated by reference in their entirety. In certain instances, it may be desirable to prepare the surfaces of the sacroiliac joint prior to implantation of the fusion device, e.g., the intra-articular or extra-articular surfaces. While surgical preparation tools may exist for procedures in other areas of the body, tools for preparing the sacroiliac joint for fusion are lacking. Thus, the systems and methods discussed herein address the challenges in preparing the sacroiliac joint for fixation and fusion.

#### SUMMARY

One implementation of the present disclosure may take the form of a surgical preparation tool for preparing a sacroiliac joint having a sacrum and an ilium for a surgical procedure.

Aspects of the present disclosure may include a system for performing a fusion procedure on a sacroiliac joint defined between a sacrum and an ilium. In certain instances, the system may include a working cannula that may include a proximal end, a distal end, a tubular body extending between the proximal and distal ends, a cannula passageway defined within the tubular body and having a cannula axis extending there through, a pair of prongs coupled to the tubular body and extending distally there from, an anchor arm engagement structure coupled to the tubular body, and a pin guide coupled to the tubular body and defining a pin passageway having a guidance axis there through that may be generally parallel with the cannula axis.

In certain instances, the pair of prongs may lie in a plane that intersects the cannula axis.

In certain instances, the pair of prongs may lie in a plane that intersects the guidance axis.

In certain instances, the pair of prongs may lie in a plane that intersects the cannula axis and the guidance axis.

In certain instances, the tubular body may include an inner surface that defines the cannula passageway, the inner surface including a pair of protrusions extending inward from opposite sides of the inner surface.

In certain instances, the system further may include an anchor arm including a cannula engagement structure configured to couple to the anchor arm engagement structure of the working cannula, the anchor arm further may include an anchor block engagement structure, and an elongate member coupled to the anchor block engagement structure and the cannula engagement structure.

In certain instances, the system further may include an anchor block including an anchor arm engagement structure configured to couple to the anchor block engagement structure of the anchor arm, the anchor block may include a plurality of guide holes extending through the anchor block and configured to guide a pin along a trajectory.

In certain instances, the anchor block further may include at least one guide slot having an elongated opening extending there through, the at least one guide slot configured to guide a tool along a plurality of trajectories that are limited to those generally within a plane defined by the elongated opening.

In certain instances, the tool may include a pin.

In certain instances, the system further may include a standoff may include a tubular body configured to be positioned within the passageway of the working cannula at the proximal end.

In certain instances, the standoff further may include an inner surface including a pair of protrusions extending inward from opposite sides of the inner surface, wherein, when the standoff may be positioned within the passageway of the working cannula the pair of protrusions of the standoff and working cannula, respectively, are collinear with each other.

In certain instances, the system further may include an implant arm may include an implant retainer and an arm member, the implant retainer may include a shaft having a threaded end configured to couple to a joint implant, the arm member may include a passageway for receiving the shaft of the implant retainer therein.

In certain instances, the system further may include the joint implant.

In certain instances, the joint implant may include an implant body including at least one planar member extending a length between a proximal end and a distal end, and an opening extending through the implant body.

In certain instances, the implant body defines X-shaped cross-section.

In certain instances, the joint implant further may include a flange coupled to the implant body, the flange being generally perpendicular to the implant body, the at least one planar member may include a first planar member, the opening extending through the first member.

In certain instances, the inner surface of the tubular body of the working cannula may be keyed to a cross-sectional shape of a joint implant to permit passage of the joint implant there through.

In certain instances, the system further may include the joint implant.

In certain instances, the tubular body may include an inner surface that defines the cannula passageway, the inner surface defining a non-circular perimeter.

In certain instances, the system further may include an anchor arm including a cannula engagement structure configured to couple to the anchor arm engagement structure of the working cannula, the anchor arm further may include an anchor block engagement structure, and an elongate member coupled to the anchor block engagement structure and the cannula engagement structure.

In certain instances, the system further may include an anchor block including an anchor arm engagement structure configured to couple to the anchor block engagement structure of the anchor arm, the anchor block may include a plurality of guide holes extending through the anchor block and configured to guide a pin along a trajectory.

In certain instances, the system further may include an implant arm that may include an implant retainer and an arm member, the implant retainer may include a shaft having a threaded end configured to couple to a joint implant, the arm member may include a passageway for receiving the shaft of the implant retainer therein, wherein, movement of the

5

implant arm and the joint implant may be independent of movement of the working cannula, the anchor arm, and the anchor block.

Aspects of the present disclosure may include a method of performing a fusion procedure on a sacroiliac joint defined between a sacrum and an ilium, where the sacroiliac joint may include an articular region, and the ilium may include a posterior superior iliac spine (PSIS) and a posterior inferior iliac spine (PIIS). In certain instances, the method may include: inserting a distal tip of a working cannula between the sacrum and the ilium via a posterior access. The distal tip may include a pair of prongs separated from each other by a distance. The working cannula may include a tubular body, a cannula passageway extending through the tubular body, a pin guide coupled to the tubular body and defining a pin passageway having a guidance axis there through that may be generally parallel with the cannula axis, and an anchor arm engagement structure. The method may further include inserting a guide pin into the ilium, securing the guide pin to the pin guide, inserting a joint implant through the cannula passageway and at least partially into the articular region of the sacroiliac joint, coupling a cannula engagement structure of an anchor arm to the anchor arm engagement structure of the working cannula, coupling an anchor block to the anchor arm, the anchor block may include a plurality of guide holes extending there through, inserting a pin through one of the plurality of guide holes and into the ilium along a trajectory defined by the one of the plurality of guide holes, and guiding a bone anchor into the ilium via guidance by the pin.

In certain instances, the method further may include inserting a distal portion of a cutting tool through the cannula passageway and into the sacroiliac joint so as to prepare the sacrum and the ilium for insertion of the joint implant.

In certain instances, the cutting tool may include at least one tool from a group may include a rasp, a drill bit, a saw blade, and a box osteotome.

In certain instances, securing the guide pin to the pin guide may be via a screw lock of the pin guide.

In certain instances, the tubular body may include an inner surface that defines the cannula passageway, the inner surface including a pair of protrusions extending inward from opposite sides of the inner surface.

In certain instances, the method further may include decoupling the anchor block from the anchor arm prior to guiding the bone anchor into the ilium by the pin.

In certain instances, the method further may include decoupling the cannula engagement structure of the anchor arm and the anchor arm engagement structure of the working cannula prior to guiding the bone anchor into the ilium by the pin.

In certain instances, the guide pin may be inserted into the PSIS of the ilium.

In certain instances, the method further may include removing bone material from the PSIS in preparation for inserting the guide pin therein.

In certain instances, the method further may include implanting the bone material into at least one or both of the joint implant and the sacroiliac joint.

In certain instances, the joint implant may be inserted at least partially into the articular region of the sacroiliac joint via a posterior access region defined between the PSIS and the PIIS.

Aspects of the present disclosure may include a system for preparing a sacroiliac joint having a sacrum and an ilium for a surgical procedure. The system may include: a plurality

6

of pins; a tissue protector or working cannula; a depth gauge; a guide block standoff; a drill guide block; a tool guide block; a plurality of keel drill blocks; a joint implant; and a delivery tool.

In certain instances, the plurality of pins may be configured to be inserted along a plane of the sacroiliac joint in generally a parallel fashion between a PSIS and a PIIS.

In certain instances, the tissue protector may include a generally block shaped body having four inner walls defining a generally square throughway, an open distal end, an open proximal end, a first pin hole passageway for receiving a first of the plurality of pins there through, a second pin hole passageway for receiving a second of the plurality of pins there through, and a transverse attachment point for a handle or other structure, the first and second pin hole passages being on opposite sides of the body and not obscuring the square throughway, the tissue protector configured to be delivered up to a posterior boundary of the sacroiliac joint via the first and second pins being received in the first and second pin hole passages, respectively.

According to particular embodiments, the tissue protector may have an inner wall configuration which provides an singular fixturing arrangement or an indexable fixturing arrangement relative to the various inserts, jigs, guide blocks or tools which engage the inner walls in order to provide a precise singular orientation or set of orientations, respectively, of the inserts, jigs, guide blocks or tools. The inner walls may comprise at least one of curved surfaces or planar surfaces. For example, a singular orientation of a drill guide block having multiple drill guide bores may align the multiple drill guide bores to all be generally coplanar with the plane of the sacroiliac joint while preventing a second orientation, for example, where the multiple drill guide bores are all aligned generally perpendicular with the plane of the sacroiliac joint. For example, a set of orientations may include providing an arrangement such that the drill guide block and the tool guide block may be oriented within the tissue protector in only two orientations, a first orientation being a mirror of a second orientation such that the guide blocks are able to be placed in the tissue protector in a zero degree orientation or a 180 degree orientation while, for example, preventing a 90 degree orientation or 270 degree orientation thereby improving precision between steps of the procedure by design in order to avoid unintentional misorientation of any of the cutting or implantation steps.

According to particular embodiments, the tissue protector may have a transverse attachment point for a handle or other structure (e.g. to allow attachment to a surgical table either directly or via an (e.g., FISSO brand) articulating arm surgical tool holder).

In certain instances, the depth gauge guide block may be configured to fit longitudinally within or nest within the four inner walls of the tissue protector via insertion through the open proximal end of the tissue protector, the depth gauge guide block may include a generally block like structure with a plurality of longitudinal through-bores extending there through, the plurality of longitudinal through-bores configured to receive depth pins there through to gauge, e.g.: at least one of i) a depth of the sacroiliac joint at different points along an anterior border of the joint, ii) the distance up to an entry point of the articular portion of the SI joint adjacent the distal end of the tissue protector, or iii) the distance up to the cortical surface of the ilium or sacrum adjacent the distal end of the tissue protector.

In certain instances, the guide block standoff may be configured to couple to the depth gauge guide block or other components of the system so as to limit a depth of insertion

to a desired amount. The system may comprise multiple sizes of guide block standoffs which are configured to limit a depth of insertion to preselected desired amounts which may be selected based on information obtained from measurements while using either the depth gauge guide block or a separate depth gauge without the use of a depth gauge guide block.

In certain instances, the drill guide block may be configured to fit longitudinally within or nest within the four inner walls of the tissue protector via insertion through the open proximal end of the tissue protector, the drill guide block may include a generally block like structure with a drill guide bore extending longitudinally there through, when the drill guide block is nested within the tissue protector, the bore is oriented to guide a drill along a predetermined path relative to the tissue protector and first and second pins.

According to particular embodiments, the drill guide block may comprise at least one of a single drill guide bore, two or more spaced apart drill guide bores, two or more overlapping drill guide bores, a slot drill guide bore or a curved slot drill guide bore.

In certain instances, the tool guide block configured to fit longitudinally within or nest within the four inner walls of the tissue protector via insertion through the open proximal end of the tissue protector, the tool guide block may include a generally block like structure with a particularly shaped longitudinal passageway having a cross-sectional shape that generally matches a cross-sectional shape of an implant to be delivered or that permits passage of the implant and a plurality of tools there through, the plurality of tools may include: an osteotome having a pair of oppositely oriented longitudinal projections projecting from an outer surface of the osteotome, the projections configured to fit within the longitudinal passageway; a rasp having a pair of oppositely oriented longitudinal projections projecting from an outer surface of the rasp; a broach guide having a pair of oppositely oriented longitudinal projections projecting from an outer surface of the broach guide; and a broach having multiple cutting edges and configured to cut the sacrum and ilium with a stroke from the broach (or a series of progressively larger broaches; or a chisel or series of progressively larger chisels).

In certain instances, the plurality of keel drill blocks, each configured to fit longitudinally within or nest within the four inner walls of the tissue protector via insertion through the open proximal end of the tissue protector, each of the plurality of keel drill blocks may include a longitudinal through bores defining a pattern and spaced a certain distance apart, the through bores configured to guide a drill in forming a portion of an implant receiving space in the sacrum or the ilium, the plurality of keel drill blocks being arranged in progressively larger or more spaced apart through bores. For example, the pattern of a first keel drill block may have the bores located furthest away from a longitudinal axis of the first keel drill block such that when employed the drill holes are located in the sacrum and ilium at the terminal edges of the keel portion of the implant receiving space; and, for example, the pattern of a second keel drill block may have the bores located closer to a midline of the keel drill block such that when employed the drill holes are located in the sacrum and ilium adjacent the holes at the terminal edges of the keel portion of the implant receiving space and closer to the plane of the sacroiliac joint such that after using one or more keel drill blocks a drilled out implant receiving space approximates at least a portion of a net shape of the implant.

In certain instances, the joint implant may be configured to couple to an implant arm and be delivered through the longitudinal passageway of the tool guide block, the joint implant may include a planar top member, a planar bottom member, a distal member connecting a distal portion of the top and bottom member, and a proximal member connecting a proximal portion of the top and bottom member, the joint implant defining a transverse passageway between the distal and proximal members for receiving an anchor or biocompatible material therein.

In certain instances, the delivery tool may include the implant arm, an anchor arm, and an adjustment arm coupling the implant arm and anchor arm, the anchor arm may include a through bore configured to guide the placement of an anchor to a predetermined position and orientation relative to the joint implant; the adjustment arm configured to arcuately extend and retract so as to change an angle of delivery of the anchor relative to the joint implant, the through bore of the anchor arm configured to guide preparation tools including an awl, a center drill, a drill bit, a spatulate tipped tool, a ball-end tool (for providing tactile feedback of whether the bore formed in the bones terminates in soft tissue or within the bones), depth gauge, tap for a screw implant (or broach for a non-threaded implant), and screw driver (or other implantation tool) for progressively preparing the bones of the sacrum or the ilium for delivery of the anchor.

In certain instances, the delivery tool further may include a guide block insertion tool configured to couple to the adjustment arm, the guide block insertion tool may include a plurality of through holes of differing orientation for inserting the anchor arm there through, the differing orientation configured to orient the anchor arm in different trajectories relative to the joint implant.

In certain instances, the guide block insertion tool may be custom manufactured for a particular patient based off of pre-operative imaging studies in order to provide custom configurations, orientations and trajectories of the through holes such that various tools and implants may be delivered via the custom through holes to arrive at preselected locations within the patient.

In certain instances, the drill guide block further may include another drill guide bore positioned inferior, and in-line with the drill guide bore.

In certain instances, the cross-sectional shape of the longitudinal passageway may include an I-beam shape with an additional midline cross through the I-beam shape.

In certain instances, the cross-sectional shape of the longitudinal passageway may include an X shape.

In certain instances, the cross-sectional shape of the longitudinal passageway may include a + shape.

In certain instances, the adjustment arm may include a closed tubular structure, e.g., having a circular, oval, polygonal, rectangular, square, half round, half oval, or other hybrid partially planar/partially arcuate or curved cross section shape.

In certain instances, the adjustment arm may include non-tubular structural beam shape structures to resist torsional and bending forces, e.g., a I-beam, Tee bar or channel “[” cross section shape.

In certain instances, the system may further may include a trial implant configured to couple to the implant arm and to be delivered through the longitudinal passageway of the tool guide block into the implant receiving space prior to cutting the sacrum and ilium using the broach. For example, the trial implant may have a net shape which approximates the shape of the implant or only partial approximates the



shape of the implant, e.g., only the intraarticular portion of the implant without the “keels” or other members extending beyond the implant receiving space within the joint plane.

In certain instances, the trial implant may include a radiolucent body within which one or more radiopaque markers are disposed.

In certain instances, the system may further include a radiographic guidance system adapted to be received by the delivery tool, the radiographic guidance system may include a plurality of adjustable members and a plurality of radiopaque markers, the adjustable members movable to align the radiopaque markers with a radiographic system and a point of interest related to implantation of the anchor.

In certain instances, the point of interest is a structural feature of the trial implant.

In certain instances, the point of interest is an anatomical feature of one of the sacrum and the ilium.

In certain instances, the plurality of adjustable members may include: a plunger adapted to be rotationally coupled to the delivery tool; a depth gauge; and a guide arm coupled to each of the plunger and the depth gauge, the depth gauge being translatable relative to the guide arm.

In certain instances, the depth gauge may include one or more first radiopaque markers of the plurality of radiopaque markers.

In certain instances, the first radiopaque markers are distributed along a distal portion of the depth gauge in a predetermined pattern such that the first radiopaque markers may be used to measure a distance relative to the point of interest in a radiographic image when the first radiopaque markers are aligned with a radiographic system and the point of interest.

In certain instances, when the plunger is disposed within one of the through bore of the anchor arm or a through hole of the guide bloc insertion tool, a distal end of the plunger extends to an anchor implantation location.

In certain instances, the depth gauges may include one or more first radiopaque markers of the plurality of radiopaque markers, the plunger may include one or more second radiopaque markers of the plurality of radiopaque markers, and aligning the radiopaque markers with the radiographic system and the point of interest further includes aligning the one or more first radiopaque markers with the one or more second radiopaque markers.

While multiple embodiments are disclosed, still other embodiments of the present disclosure will become apparent to those skilled in the art from the following detailed description, which shows and describes illustrative embodiments of the disclosure. As will be realized, the various embodiments of the present disclosure are capable of modifications in various aspects, all without departing from the spirit and scope of the present disclosure. Accordingly, the drawings and detailed description are to be regarded as illustrative in nature and not restrictive.

#### BRIEF DESCRIPTION OF THE DRAWINGS

FIG. 1 is an anterior view of the pelvic region and a conventional method and device for stabilizing the sacroiliac joint.

FIG. 2A is an isometric view of a first embodiment of a system for fusing a sacroiliac joint.

FIG. 2B is the same view as FIG. 2A, except the delivery tool and implant assembly are decoupled from each other.

FIG. 3 is the same view as FIG. 2A, except the system is exploded to better illustrate its components.

FIG. 4 is a posterior-inferior view of a sacroiliac joint with a patient body shown in broken line.

FIG. 5 is a close-up view of the implant and anchor element in the sacroiliac joint.

FIG. 6 is an enlarged view of the hip region where the nearest ilium is removed to show the sacroiliac joint space boundary defined along the sacrum and an implant positioned for implantation within the joint space.

FIG. 7 is an isometric view of a delivery tool with an implant arm coupled to an implant, where the implant arm extends through a working cannula.

FIG. 8 is a medial view of a sacrum and ilium with a nearest ilium removed so as to clearly view a parallel pin guide and three pins extending there through.

FIG. 9 is the medial view of the sacrum and ilium of FIG. 8, but with a working cannula in position via guidance by the three pins.

FIG. 10A is the medial view of the sacrum and ilium of FIG. 8, and with a drill guide block positioned within the working cannula, and a drill being guided by the drill guide block with depth being limited by a standoff.

FIG. 10B is a rear view of the drill guide block.

FIG. 11A is the medial view of the sacrum and ilium of FIG. 8, and with a rasp positioned within the working cannula with depth being limited by a standoff.

FIG. 11B is a rear view of a tool guide block for fitting within the working cannula and guiding various tools.

FIG. 11C is an isometric view of a rasp.

FIG. 12A is the medial view of the sacrum and ilium of FIG. 8, and with the implant coupled to the implant arm of the delivery tool, where the implant arm is positioned within the tool guide block and the working cannula with depth being limited by a standoff.

FIG. 12B is an isometric view of an exemplary joint implant.

FIG. 13 is an isometric view of a delivery tool and an implant.

FIG. 14 is a cross-sectional isometric view of the delivery tool and implant.

FIG. 15 is an isometric view of the implant arm, the implant, a cannula insertion tool, a tamp insertion tool, and a luer lock adapter.

FIG. 16 is a close-up, cross-sectional, isometric view of the implant and the distal member of the implant arm with the cannula insertion tool (fully inserted) and tamp insertion tool (partially inserted) nested therein.

FIG. 17 is a close-up isometric view of the implant uncoupled from the distal member of the implant arm.

FIG. 18 is an isometric view of an implant trial with radiographic markers.

FIG. 19 is an isometric view of a radiographic system in use with the implant trial.

FIG. 20 is an isometric view of a radiographic system in use with the implant trial, and a close-up view of a radiographic image.

FIG. 21 is an isometric view of a radiographic system in use with the implant trial and an elongate plunger having a radiographic marker.

FIG. 22 is an isometric view of a radiographic system in use with the implant trial, the elongate plunger, and a close-up view of a radiographic image.

FIG. 23 is a distal isometric view of a sacroiliac joint delivery system.

FIG. 24 is a proximal isometric view of the sacroiliac joint delivery system of FIG. 23.

FIG. 25 is a side isometric view of the sacroiliac joint delivery system of FIG. 23.

FIG. 26 is a side view of the sacroiliac joint delivery system of FIG. 23, except the joint implant is coupled to the implant arm of the system.

FIGS. 27A-27D are respectively isometric, top, side, and front views of a joint finder.

FIGS. 28A-28D are respectively isometric, top, back, and side views of a working cannula or tissue protector.

FIGS. 29A-29D are respectively isometric, top, back, and side views of a depth gauge.

FIGS. 30A-30D are respectively isometric, top, back, and side views of a standoff.

FIGS. 31A-31D are respectively isometric, top, back, and side views of a drill guide insert.

FIGS. 32A-32B are respectively isometric and side views of a drill bit.

FIGS. 33A-33D are respectively isometric, top, back, and side views of a box osteotome.

FIGS. 34A-34D are respectively isometric, top, back, and side views of a dual chisel blade (or broach, saw blade or other cutting profile) broach.

FIGS. 35A-35D are respectively isometric, top, back, and side views of an anchor arm.

FIGS. 36A-36D are respectively isometric, top, side, and front views of an anchor block.

FIGS. 37A-37D are respectively isometric, top, back, and side views of an implant arm.

FIGS. 38A-38D are respectively isometric, top, back, and side views of a joint implant.

FIG. 39 is an isometric view of an exemplary working cannula and anchor arm removably coupled thereto.

FIG. 40 is a close up, rear isometric view of the connection between the working cannula and the anchor arm.

FIG. 41 is an exploded, rear isometric view of the working cannula, anchor arm, and a standoff.

FIG. 42 is an exploded, front isometric view of the working cannula, and anchor arm.

FIG. 43 is a close up view of the working cannula and anchor arm of FIG. 42.

FIG. 44 is a close up, rear isometric view of the working cannula, and anchor arm.

FIG. 45 is a side cross-sectional view of the working cannula and the anchor arm coupled together.

FIG. 46 is a side cross-sectional view of the distal end of the working cannula.

FIG. 47 is an isometric view of a bone anchor.

FIGS. 48A-48B are respectively top and side views of the bone anchor of FIG. 47.

FIGS. 49A-49B are respectively back and front views of the bone anchor of FIG. 47.

FIG. 50 is an isometric view of a bone anchor.

FIGS. 51A-51F are respectively top, first side, second side, third side, back, and front views of the bone anchor of FIG. 50.

FIGS. 52-56 are respectively front isometric, rear isometric, front, side and top views of a flanged implant.

FIG. 57 is a posterior view of the flanged implant bridging across the sacroiliac joint.

FIG. 58 is a posterior-lateral view of the flanged implant bridging across the sacroiliac joint.

FIGS. 59A-59B are respectively rear isometric, and side isometric views of a joint implant.

FIGS. 60A-60D are respectively first side, second side, back, and front views of the joint implant of FIGS. 59A-59B.

FIGS. 61A-61B are respectively top and bottom views of the joint implant of FIGS. 59A-59B.

FIG. 62 is a posterior view of the joint implant bridging across the sacroiliac joint.

FIG. 63 is a superior view of the joint implant bridging across the sacroiliac joint, where the ilium forming a portion of the sacroiliac joint is removed to show the position of the joint implant.

FIG. 64 is a side view of a pelvis with a joint finder positioned proximally thereof.

FIG. 65 is a side view of a pelvis with the joint finder positioned in the sacroiliac joint (the steps shown in FIGS. 64-65 are an alternative to the steps shown in FIGS. 66-68, i.e., employing a non-cannulated versus cannulated joint finder).

FIG. 66 is a side view of a pelvis with a pin positioned in the sacroiliac joint.

FIG. 67 is a side view of a pelvis with the nearest ilium removed to show the pin in the sacroiliac joint.

FIG. 68 is a side view of a pelvis with the nearest ilium removed, and a cannulated joint finder positioned over the pin and in the sacroiliac joint.

FIG. 69 is a side view of a pelvis with the nearest ilium removed, and a working cannula positioned over the cannulated joint finder and the pin and in the sacroiliac joint.

FIG. 70 is a posterior view of the pelvis with the working cannula, cannulated joint finder, and pin positioned in the sacroiliac joint.

FIG. 71 is a superior view of the pelvis with the working cannula, cannulated joint finder, and pin positioned in the sacroiliac joint and a threaded guidance pin (e.g., a self-drilling and/or self-tapping Schanz screw) inserted through the pin guide at the proximal end of the working cannula and threaded into the area of the ilium near the PSIS and configured and positioned to anchor and stabilize the working cannula in relation to the patient's bony anatomy in lieu of or in addition to attaching the working cannula to the operative table.

FIG. 72 is a side view of a pelvis with a guidance pin secured to the posterior superior iliac spine of the ilium.

FIG. 73 is a side view of the pelvis with the pin removed from the joint, and a button knob coupled to the proximal end of the cannulated joint finder.

FIG. 74 is a side view of the pelvis with a slide (or slap) hammer assembly coupled to the button knob.

FIG. 75 is a side view of the pelvis with the cannulated joint finder removed via the slide hammer from within the working cannula, which is still in the joint.

FIG. 76 is a side view of the pelvis with a depth gauge and the working cannula.

FIG. 77 is a side view of the pelvis with the nearest ilium removed, and the depth gauge positioned through the working cannula and in the joint in order to allow a medical person to evaluate with intra-operative imaging (e.g., with a lateral view) a desired depth of joint preparation and/or desired depth of implant placement (e.g., the joint may be prepared further distally than the desired implant depth in order to prepare more of the joint for fusion and may include packing/tamping bone graft or other biocompatible material distal to the final location of the implant).

FIG. 78 is a side view of the pelvis with a standoff positioned proximate the working cannula, the standoff size being selected from a set of standoffs corresponding with the measurements obtained from the evaluation with the depth gauge.

FIG. 79 is a side view of the pelvis with a standoff positioned within the working cannula.

FIG. 80 is a posterior view of the pelvis, the working cannula, the guidance pin and the standoff.

## 13

FIG. 81 is a side view of the pelvis with the nearest ilium removed, and a drill guide positioned proximate the working cannula.

FIG. 82 is a side view of the pelvis with the nearest ilium removed, and a drill bit positioned proximate the working cannula and drill guide positioned therein.

FIG. 83 is a side view of the pelvis with the nearest ilium removed, and a drill extending through a central guide of the drill guide, and into the joint.

FIG. 84 is a side view of the pelvis with the nearest ilium removed, and a drill extending through a superior guide of the drill guide, and into the joint.

FIG. 85 is a posterior view of the pelvis with the drill positioned in the superior guide of the drill guide, and the working cannula positioned in the joint.

FIG. 86 is a side view of the pelvis with the nearest ilium removed, and a drill extending through an inferior guide of the drill guide, and into the joint.

FIG. 87 is a side view of the pelvis with the nearest ilium removed, and a box osteotome positioned proximate the working cannula.

FIG. 88 is a side view of the pelvis with the nearest ilium removed, with the box osteotome extending through the working cannula and into the joint (while the present figure shows an embodiment of the box osteotome without a physical stop and instead with laser markings along the shaft an embodiment such as shown in FIG. 33 may be employed having a physical stop (e.g., configured as a flanged base) and delivered to a maximum depth similar to the step shown in FIG. 91 where the flanged base contacts the proximal end of the standoff).

FIG. 89 is a side view of the pelvis with the nearest ilium removed, and a dual saw blade broach positioned proximate the working cannula.

FIG. 90 is a superior view of the dual saw blade broach and the working cannula of FIG. 89.

FIG. 91 is a side view of the pelvis with the nearest ilium removed, with the dual saw blade broach positioned through the working cannula and into the joint.

FIG. 92 is a side view of the pelvis with the nearest ilium removed, and a joint implant coupled with an implant arm that is positioned proximate the working cannula.

FIG. 93 is a superior view of the joint implant coupled with an implant arm positioned proximate of the working cannula.

FIG. 94 is a side view of the pelvis with the nearest ilium removed, and the joint implant positioned in the joint, and coupled to the implant arm, which extends through the working cannula (the implant arm may have a physical stop such as a flanged base as similarly shown with the other tools or may have laser marking along the shaft near the proximal end configured and calibrated with a zero marking being a equivalent depth as the joint preparation tools as read from the proximal surface of the standoff and plus or minus various depth measurements, e.g., 5, 10 and 15 mm increments in order to allow the surgeon to select and verify implant positioning to be delivered further distally or proximally to the prepared implant receiving space).

FIG. 95 is a superior view of the joint implant positioned in the joint, and coupled to the implant arm, which extends through the working cannula.

FIG. 96 is a side view of the pelvis with the nearest ilium removed, and an anchor arm positioned proximate the working cannula.

FIG. 97 is a superior view of the anchor arm positioned proximate the working cannula.

## 14

FIG. 98 is a superior view of the anchor arm coupled to the working cannula.

FIG. 99 is a posterior view of the anchor arm coupled to the working cannula.

FIG. 100 is a side view of the pelvis with the nearest ilium removed, and the working cannula coupled to the anchor arm.

FIG. 101 is a side view of the pelvis with an anchor block coupled to the anchor arm, which is coupled to the working cannula.

FIG. 102 is a posterior view of the pelvis with the anchor arm coupled to the working cannula, and with the anchor block coupled to the anchor arm.

FIG. 103 is a superior view of the pelvis with the anchor arm coupled to the working cannula, and with the anchor block coupled to the anchor arm.

FIG. 104 is a side view of the pelvis with an anchor block coupled to the anchor arm, which is coupled to the working cannula, and a K-wire guided towards the ilium via the anchor block.

FIG. 105 is a posterior view of the pelvis with an anchor block coupled to the anchor arm, which is coupled to the working cannula, and a K-wire guided towards the ilium via the anchor block.

FIG. 106 is a superior view of the pelvis with an anchor block coupled to the anchor arm, which is coupled to the working cannula, and a K-wire guided towards the ilium via the anchor block.

FIG. 107 is a superior view of the pelvis with an anchor block coupled to the anchor arm, which is coupled to the working cannula, and a K-wire extending into the ilium via guidance by the anchor block.

FIG. 108 is a superior view of the pelvis with an anchor block being decoupled from the anchor arm, which is coupled to the working cannula.

FIG. 109 is a superior view of the pelvis with the K-wire remaining in the pelvis, but with the rest of the tools removed. A bone anchor is guided to the ilium via the K-wire.

FIG. 110 is a superior view of the pelvis with the bone anchor extending into the ilium, across the joint, and into the sacrum via guidance by the K-wire.

FIG. 111 is a side view of the pelvis with the bone anchor in position, and with the joint implant in the joint (not seen).

FIG. 112 is a side view of the pelvis with the nearest ilium removed so as to view the joint implant positioned within the joint, and the bone anchor extending across the joint.

FIG. 113 is a posterior view of the pelvis with the nearest ilium removed so as to view the joint implant positioned within the joint, and the bone anchor extending across the joint.

FIG. 114 is an isometric side view of the joint implant and the bone anchor in position adjacent each other in an implanted orientation in the joint.

FIG. 115 is a distal isometric view of an exemplary working cannula, an anchor arm, and a pin guide removably coupled together.

FIG. 116 is proximal isometric view of the exemplary working cannula, the anchor arm, and pin guide uncoupled from each other.

FIGS. 117A-117C are, respectively, a pair of isometric side views and a back view of a joint finder.

FIGS. 118A and 118B are, respectively, side isometric and side isometric exploded views of a broach.

## DETAILED DESCRIPTION

The present application incorporates by reference the following patent applications in their entireties: Ser. No.

12/998,712 filed on May 23, 2011; Ser. No. 13/135,381 filed on Jul. 1, 2011; Ser. No. 14/127,119 filed on Dec. 17, 2013; Ser. No. 13/236,411 filed on Sep. 19, 2011; Ser. No. 13/475,695 filed on May 18, 2012; Ser. No. 13/945,053 filed on Jul. 18, 2013; Ser. No. 13/946,790 filed on Jul. 19, 2013; Ser. No. 14/344,876 filed on Mar. 13, 2014; Ser. No. 14/216,975 filed on Mar. 17, 2014; Ser. No. 14/681,882 filed on Apr. 8, 2015; Ser. No. 15/061,524 filed on Mar. 4, 2016; Ser. No. 15/178,244 filed on Jun. 9, 2016; Ser. No. 15/178,291 filed on Jun. 9, 2016; Ser. No. 15/216,472 filed on Jul. 21, 2016; Ser. No. 15/664,608 filed on Jul. 31, 2017; Ser. No. 15/664,862 filed on Jul. 31, 2017; Ser. No. 14/514,221 filed on Oct. 14, 2014, now U.S. Pat. No. 9,826,986; Ser. No. 14/723,384 filed on May 27, 2015; Ser. No. 14/567,956 filed on Dec. 14, 2014; Ser. No. 14/447,612 filed Jul. 31, 2014; Ser. No. 14/413,318 filed Jan. 7, 2015; Ser. No. 15/418,633 filed on Jan. 27, 2017; 62/608,476 filed Dec. 20, 2017; 62/609,095 filed Dec. 21, 2017; 62/632,635 filed Feb. 20, 2018; and 62/640,026 filed Mar. 8, 2018.

Implementations of the present disclosure involve a system for preparing a sacroiliac joint for fusion. In particular, the system may include a preparation tool for removing articular cartilage from the sacroiliac joint space, abrading of the articular surfaces to enhance bony fusion, and removal of portions of the cortical, subchondral or cancellous bone for implantation of a fusion device. The preparation tool may include an anchoring arm that is configured to direct an anchoring element for transverse delivery through the sacroiliac joint space. The anchor may be delivered into the joint space before, during, or after the joint space is prepared for implant delivery. Alternatively, an implant may not be delivered into the joint and instead, e.g., bone paste or slurry may be introduced into the prepared sacroiliac joint before or after anchor placement. And, the anchor may be delivered cranial, caudal, in front of, behind, above, below, next to, up to, near, adjacent, away from, through, or in-line with the eventual placement of the implant. The preparation tool is configured to quickly, accurately and reliably prepare the joint space for insertion of an implant.

Implementations of the present disclosure may further include radiographic tools adapted to confirm placement of the joint implant and anchors prior to their implantation. According to particular embodiments, a radiographic tool may include a radiographic implant template (not shown) positioned near, up to or within the patient's body in order to approximate the orientation, location, size, configuration and implantation trajectory of the implant and employed either: i) prior to the incision of the patient's skin, ii) prior to the preparation of the sacroiliac joint, iii) prior to the creation of the central portion of the implant receiving space, iv) prior to the creation of substantially the entire implant receiving space, v) after placement of a pin or other guidance instrument (e.g., joint finder) into the sacroiliac joint, vi) after the preparation of the sacroiliac joint, vii) after the creation of the central portion of the implant receiving space, viii) after the creation of substantially the entire implant receiving space; for example, the implant template may include a shape comprising a cross section of the implant and may further comprise an overlapping pattern of implant sizes or configurations in order to determine, e.g., desired implant size or configuration in relation to the sacroiliac joint an surrounding anatomy. As an example, such tools may be used after removing articular cartilage but prior to abrading or otherwise removing the cortical, subchondral or cancellous bone of the joint. The tools may be used before making cuts for keels or other members extending beyond the portion of the implant at the plane of the joint and after

preparing the plane of the sacroiliac joint in order to create at least a portion of the implant receiving space, which, e.g., may approximate the shape and size of the portion of the implant to be situated therein and, e.g., may be configured to accommodate a cylindrical body, a rectangular body. In other aspects the implant receiving space may be fully prepared before employing the radiographic tools. The radiographic tools generally include radiopaque markers or structures that are viewable using a radiography system, such as a fluoroscope or X-ray. By aligning the radiopaque markers/structures with anatomical features of the patient or other radiopaque elements of the tools, parameters for implanting the anchors (such as anchor configuration and size, location, orientation, and depth) may be determined and confirmed prior to the substantial tissue removal required for implanting the joint implant and/or the anchor.

#### I. System for Fusion of the Sacroiliac Joint

To begin a detailed discussion of an exemplary system **10** for delivering an implant **12** into the sacroiliac joint, reference is made to FIGS. **2A-3**. FIG. **2A** is an isometric view of the system **10**. FIG. **2B** is the same view as FIG. **2A**, except an implant assembly **14** of the system **10** is separated from a delivery tool **16** of the system **10**. FIG. **3** is the same view as FIG. **2A**, except the system **10** is shown exploded to better illustrate the components of the system **10**.

As can be understood from FIGS. **2A** and **2B**, the system **10** includes a delivery tool **16** and an implant assembly **14** for implanting at the sacroiliac joint via the delivery tool **16**, the implant assembly **14** being for fusing the sacroiliac joint. As indicated in FIG. **3**, the implant assembly **14** includes an implant **12** and an anchor element **18** (e.g., a bone screw or other elongated body). As discussed below in greater detail, during the implantation of the implant assembly **14** at the sacroiliac joint, the implant **12** and anchor element **18** are supported by a distal end **20** of the delivery tool **16**, as illustrated in FIG. **2A**. The delivery tool **16** is used to deliver the implant **12** into the sacroiliac joint space. The delivery tool **16** is then used to cause the anchor element **18** to extend through the ilium, sacrum and implant **12** generally transverse to the sacroiliac joint and implant **12**. The delivery tool **16** is then decoupled from the implanted implant assembly **14**, as can be understood from FIG. **2B**. As illustrated in FIG. **3**, the delivery tool **16** further includes a proximal end **22** opposite the distal end **20**, an arm assembly **24**, a handle **26**, an implant retainer **28**, a sleeve **30** and a trocar or guidewire **32**. While in the embodiment of FIGS. **2A-3**, the delivery tool **16** is fixed and non-adjustable and configured to deliver the anchoring element **18** in a single orientation relative to the implant **12**, the delivery tool **16** may be adjustable and configured to deliver the anchoring element **18** within a range of orientations relative to the implant **12** that will orient the anchoring element **18** either within a bore of the implant **12**, or adjacent implant **12**, e.g., as described in U.S. patent application Ser. No. 14/447,612, filed Jul. 31, 2014, entitled SYSTEMS FOR AND METHODS OF FUSING A SACROILIAC JOINT, which is hereby incorporated by reference in its entirety or as described by an of the other applications reference in this application.

In particular embodiments, and with reference to FIG. **6**, first and second articular faces of the implant **25** may be selected to match the contour of the joint space of the sacroiliac joint within which the implant **12/25** is to be inserted. For example, the sacral, medial or first articular face of the implant **25** may be configured to be generally convex to match the contour of a sacral auricular bony surface or to match the contour of an extra-articular region of a sacrum (e.g., a sacral fossa). In one aspect and referring

to portions of the anatomy shown FIG. 6, the sacral, medial or first articular face of the implant may be generally a surface negative of the articular surfaces 1016 of the extra-articular region 3007 and/or articular region 1044 of the sacrum 1004. As another example, the lateral, iliac or second articular face of the implant 12 may be configured to be generally concave to match the contour of an iliac auricular bony surface or to match the contour of an extra-articular region of an ilium (e.g., an iliac tuberosity). In one aspect, the lateral, iliac or second articular face of the implant 12/25 may be generally a surface negative of the articular surfaces 1016 of the extra-articular region 3007 and/or articular region 1044 of the ilium 1005.

To begin a discussion of implant delivery into the sacroiliac joint articular region 1044, reference is made to FIG. 6, which is a close-up lateral side view of the pelvis or hip region 1002 of a patient 1001 with a nearest ilium 1005 removed in order to show the sacroiliac joint boundary 3000 defined along the sacrum 1004 and outlining the sacroiliac joint articular region 1044, and an implant 25 positioned for implantation within the sacroiliac joint articular region 1044. The opposite ilium 1005 is visible, including the landmarks of the posterior superior iliac spine 2004 and the tubercle of the iliac crest 2012, among other landmarks.

As seen in FIG. 6, boundaries along the sacroiliac joint articular region 1044 include an inferior boundary segment 3002, an anterior boundary segment 3004, a superior boundary segment 3006, and a posterior boundary segment 3008. The inferior boundary segment 3002 is immediately adjacent, and extends along, the sciatic notch 2024.

The inferior boundary segment 3002 and anterior boundary segment 3004 intersect to form an anterior-inferior corner 3010. The anterior boundary segment 3004 and superior boundary segment 3006 intersect to form an anterior-superior corner 3012. The superior boundary segment 3006 and posterior boundary segment 3008 intersect to form a superior-posterior corner 3014. The posterior boundary segment 3008 and posterior inferior access region 2016 intersect to form a superior-posterior corner 3016 of the posterior inferior access region 2016. The inferior boundary segment 3002 and posterior inferior access region 2016 intersect to form an inferior-posterior corner 3018 of the posterior inferior access region 2016.

The inferior boundary segment 3002 extends between corners 3010 and 3018. The anterior boundary segment 3004 extends between corners 3010 and 3012. The superior boundary segment 3006 extends between corners 3012 and 3014 and provides an access into the cranial portion 1087 of the sacroiliac joint. The posterior boundary segment 3008 extends between corners 3014 and 3016. The posterior inferior access region 2016 extends between corners 3016 and 3018 and provides an access into the caudal region 1086 of the sacroiliac joint. The posterior boundary segment 3008 separates articular region 1044 and extra-articular region 3007, which includes the sacral fossa on the sacrum 1004 and the corresponding iliac tuberosity on the ilium 1005 and defined by the extra-articular region boundary 3009.

In one aspect and as seen in FIG. 6, the implant 25 may be coupled to a distal end 120 of an implant arm 111 of a delivery tool and delivered via the implant arm 111 into the caudal region 1086 of the sacroiliac joint articular region 1044. As shown via the implant 25 and implant arm 110 shown in solid lines, in one embodiment, the implant 25 enters the posterior inferior access region 2016, and is further advanced into the caudal region 1086 of the sacroiliac joint articular region 1044, in an orientation such that the implant arm 110 and wide planar members 51 are in the

joint plane and the longitudinally extending edge 3050 of the wide planar member 51 next to the inferior boundary segment 3002 is generally parallel to, and immediately adjacent to, the inferior boundary segment 3002. Thus, the distal end 43 of the implant is heading generally perpendicular to, and towards, the anterior boundary segment 3004. A bore 40 of the implant 25 is oriented transversely to the longitudinally extending edge 3050 of the planar member 51, and extends transversely to the joint plane when implanted. As seen in FIG. 6, the bore 40 may extend through the planar member 55, which is oriented generally transverse to the wide planar member 51.

As shown in FIG. 6 via the implant 25 and implant arm 110 shown in dashed lines, in one embodiment, the implant 25 enters the posterior inferior access region 2016, and is further advanced into the caudal region 1086 of the sacroiliac joint articular region 1044, in an orientation such that the implant arm 111 and wide planar members 51 are in the joint plane and the longitudinally extending edge 3050 of the wide planar member 51 next to the inferior boundary segment 3002 is somewhere between being generally parallel to the inferior boundary segment 3002 (as illustrated by the solid-lined implant 25 in FIG. 6) or forming an angle AJ with the inferior boundary segment 3002 of up to approximately 50 degrees. Thus, the distal end 43 of the implant shown in dashed lines can be said to head anywhere from generally perpendicular to, and towards, the anterior boundary segment 3004 to heading generally towards the superior-anterior corner 3012, or points in between.

In one embodiment, the implant 25 may be first directed into the joint space as illustrated by the solid-lined implant 25 in FIG. 6 after which the implant 25 is rotated within the joint space to be positioned somewhere between, and including, angled position depicted by the dashed-lined implant 25. In other embodiments, the implant 25 may be first directed into the joint space as illustrated by the dashed-lined implant 25 in FIG. 6 after which the implant 25 is rotated within the joint space to be positioned somewhere between, and including, the parallel position depicted by the solid-lined implant 25. Thus, an implant 25 may be delivered non-transversely (i.e., within the joint and not across the joint) into the caudal region 1086, the cranial portion 1087, or partially within each of the caudal and cranial regions 1086, 1087 of the sacroiliac joint articular region 1044. Further details of the implant delivery can be found in related applications, mentioned previously, such as for example U.S. patent application Ser. No. 12/998,712, which is incorporated by reference herein in its entirety.

A system as described in FIGS. 2A-3 may be used in a surgical procedure via a posterior approach, as seen in FIGS. 4-6. As can be understood from FIG. 4, which is a posterior-inferior view of a sacroiliac joint 36 with a patient 40 shown in broken line, the delivery tool 16 is positioned to deliver the implant 12 into a caudal region 34 of the sacroiliac joint 36 and the anchoring element 18 through the ilium 5 and into the bore 38 of the implant 12. Referring to FIG. 5, the implant 12 and anchoring element 18 have been inserted into the caudal region 34 of the sacroiliac joint 36 and the delivery tool 16 has been removed.

With further reference to the bony anatomy shown in FIG. 6, a system as described herein may be used in a surgical procedure via an anterior approach (e.g., such that the surgical pathway includes traversing an anterior boundary segment 3004 and/or traversing an anterior-inferior corner 3010) and may further include positioning an implant into a sacroiliac joint such that: 1) the implant longitudinal axis a) is generally parallel to a sacroiliac joint inferior boundary

segment **3002**, or b) points towards a posterior superior iliac spine, or c) point towards a posterior inferior iliac spine, or d) points toward a sacroiliac extra-articular region; or, 2) the distal end of the implant generally lies within a) a caudal region of the sacroiliac joint articular region, or b) an extra-articular portion of the sacroiliac joint, or c) a cranial portion or cephalad region of the sacroiliac joint articular region.

Additionally, a system as described herein may be used in a surgical procedure via an approach which includes a surgical pathway which transverses a sacroiliac joint inferior boundary segment **3002**, e.g., as described in U.S. patent application Ser. No. 13/945,053, filed Jul. 18, 2013, entitled SYSTEMS AND METHODS OF FUSING A SACROILIAC JOINT, which is hereby incorporated by reference in its entirety. A surgical procedure via this pathway may further include positioning an implant into a sacroiliac joint such that: 1) the implant longitudinal axis a) is transverse to a sacroiliac joint inferior boundary segment **3002**, or b) points towards a posterior superior iliac spine, or c) point towards a posterior inferior iliac spine, or d) points toward a sacroiliac extra-articular region, or e) points towards a sacroiliac joint anterior boundary segment **3004**, or f) points towards either superior boundary segment corner **3014** or **3012** or somewhere in-between; or, 2) the distal end of the implant generally lies within a) a caudal region of the sacroiliac joint articular region, or b) an extra-articular portion of the sacroiliac joint, or c) a cranial portion or cephalad region of the sacroiliac joint articular region.

Furthermore, in an aspect, an implant **12** may be inserted along a generally arcuate path. Accordingly, a surgical preparation technique and tools may be utilized while operating in an arcuate path. The implant arcuate path may follow and generally match the surgical preparation arcuate path and the path arc may include a radius of between approximately 3 cm to 6 cm. The portion of the path having an arcuate path including a radius of between approximately 3 cm to 6 cm may reside substantially in the plane of the sacroiliac joint or in a plane in close proximity and generally parallel thereto. Furthermore, the arcuate path may generally or substantially reside in sacroiliac joint articular region **1044**. Additionally, an implant may be selected for use during the procedure which substantially matches the radius or curvature of the arcuate or curved insertion path or surgical preparation path.

According to a particular aspect, after drilling or otherwise producing an opening through an ilium (or sacrum) leading toward or into a sacroiliac joint, a sleeve may guide (alone or along with another cannulated tool, e.g., a needle) a bone paste, bone marrow aspirate, stem cells, allograft or any biocompatible material or substance into the sacroiliac joint space via a path with a trajectory which may be generally transverse to the plane of the sacroiliac joint. The sleeve may be caused to form a seal with a bone defining the sacroiliac joint, e.g. the ilium. The seal may be created by impacting a proximal end of sleeve which may, for example, cause the sleeve to slightly penetrate the cortex of the outer table of the ilium. Alternatively, a cannulated tool such as a large gauge needle or tube may either be interference fit within a hole in the ilium or the needle or tube may have a threaded distal end which may be threaded into the bore formed in the ilium. A plunger or bone tamp may be forced through a sleeve to advance the bone paste or other material into the sacroiliac joint space, adjacent/around the implant and/or into the bone graft window of the implant.

Subsequently, an anchor such as a bone screw may be advanced via the sleeve into engagement with an opening

formed in the ilium and driven across the sacroiliac joint and further into the sacrum. Alternatively, a bone plug may be positioned into the opening formed in the ilium in order to occlude the passageway between the outer cortex of the ilium and the implanted bone paste or other material positioned which had been positioned generally in the plane of the joint.

As such, the systems and methods described herein are directed to preparing the sacroiliac joint for surgical fusion procedures of this type and others.

## II. System for Preparing the Sacroiliac Joint for Fusion

### A. First Embodiment of Surgical Access Devices, Surgical Preparation Tools, Implant Delivery Tool and Implant.

Reference is now made to FIGS. **7-12** in the present application. Additional figures and description for the tools and methods of use can be found in Provisional Patent Application Nos. 62/559,386 filed Sep. 15, 2017, 62/609,095 filed Dec. 21, 2017, 62/632,635 filed Feb. 20, 2018, and 62/640,026 filed Mar. 8, 2018. Each of the aforementioned provisional patent applications are hereby incorporated by reference in their entireties.

Various surgical access devices, surgical preparation tools and assemblies, delivery instrumentation and implants will be discussed herein. These tools and assemblies may be used by themselves or in combination with each other. Additionally, features of a particular embodiment are non-limiting and may be incorporated into any or all other embodiments without departing from the teachings in this disclosure.

Exemplary embodiments of a system for sacroiliac joint fusion may be seen in FIG. **7**. In the figure, a joint implant **200** is coupled to a distal end **202** of an implant arm **204** of a delivery tool **206**. The implant arm **204** may extend from the joint implant **200** and an anchor arm **208** coupled to the implant arm **204**. The anchor arm **208** may deliver an anchor (not shown) in a predetermined position relative to the joint implant **200**. In certain instances, the anchor (not shown) may be delivered through a transverse opening or window **210** in the joint implant **200**. As seen in FIG. **7**, the implant arm **204**, as well as various other joint preparation tools, may extend through a working cannula **212** (otherwise known as a tissue protector). The working cannula **212** protects the patient's surrounding tissue and provides a passageway to the joint for the insertion of various tools and the implant **200**. The working cannula **212** may include a longitudinal passageway, a superior lumen **218** extending longitudinally, an inferior lumen (not shown in FIG. **7**) extending longitudinally on an opposite side of the passageway and an attachment shaft extending off the exterior of the working cannula, either permanently fixed thereto or removably coupled thereto and configured to couple with a handle or with a fixture configured to also couple with the operating table or a surgical robot and in some instances may extend transverse to the length of the working cannula and may include an angle of about 90 degrees or about 45 degrees as shown in FIG. **7** and/or may have a bayonet or dog legged configuration. According to particular embodiments, the attachment shaft may be positioned medially over the sacrum and given the orientation of the plane of the sacroiliac joint and the presence of the patient's tissue, the 45 degree angle of the attachment shaft as shown in FIG. **7** permits sufficient clearance from the skin for a handle to extend therefrom or for a coupling mechanism to attach thereto. The superior and inferior lumens **218** may accept joint pins inserted into the joint, as seen in FIG. **9**. Alternatively, the working cannula may be configured similar to the tissue protector of the systems shown in FIGS. **23, 28** and **39**, e.g., the working cannula may include a pair of prongs,

spikes, or projections at a distal end thereof instead of having superior and inferior lumens for accepting joint pins described above, or wherein the working cannula includes a lateral side having an angled opening that extends into the passageway.

Various inserts **214** may be positioned within the working cannula **212** to guide the delivery of various instruments, respectively. For example, as seen in FIG. 7, the shaft **216** of the implant arm **204** may be keyed to a corresponding shape of the insert **214** such that the implant arm **204** is prevented from rotating relative to the insert **214**. This ensures the correct rotational alignment of the implant **200** upon delivery into the joint. It is noted, the working cannula **212** may be secured to the operating room table during the surgical procedure to ensure it is in a fixed position as described above.

FIGS. 8-9, 10A, 11A, and 12A illustrate an exemplary method of preparing a joint, and delivering an implant into a joint. To begin a surgical procedure on the SI joint, the PSIS and PIIS landmarks may be identified. The plane of the articular portion may be identified with a first pin or probe. Additionally or alternatively, a spatula probe (e.g., the joint finder as shown in FIGS. 27A-27D or as shown in FIGS. 68 and 75) may be advanced into the SI joint while orienting the flat distal tip parallel to the plane of the articular portion. In some embodiments the shaft extending proximally from the flat distal tip may be cylindrical, while in other embodiments the shaft may be non-circular in cross section or the shaft or the proximal end may have a clocked or indexed configuration such that further tools may be coupled with or otherwise engaged with the non-circular or clocked or indexed portion such that they act as an orientation reference providing discrete positions or orientation of the further tools relative to the flat distal tip and therefor the plane of the articular portion of the joint.

A parallel pin guide **220** may be advanced over the pin **225** at FIG. 8 (or the spatula probe). The pin guide **220** may be a thin rectangular block with multiple through-holes (either circular or non-circular in cross-section) extending longitudinally there through as seen in FIG. 8 to accommodate multiple pins. Once the parallel pin guide is positioned over the first pin **225**, the two remaining guides are configured to align a superior and an inferior pin **225**, **225** into the joint in a predetermined relation to the first pin **225**. As illustrated in FIG. 8, the second pin/probe **225** and the third pin/probe **225** may be located superior and inferior of the first pin **225** and may generally correspond to the PSIS and the PIIS, respectively. Following placement of the pins, the pin guide may be removed.

After removal of the pin guide **220**, the pins **225** may be used to guide various tools for dilating soft tissue adjacent the sacroiliac joint and for introducing the working cannula **212**, as shown in FIG. 9. In certain applications, the first pin **225** is removed after introduction of the working cannula **212** and the working cannula may be subsequently fixed to an operating table or other fixture in the vicinity of the patient or held using a handle extending from the working cannula. FIG. 10A, for example, illustrates a working cannula **212** in place with the first pin **225** removed. A drill guide insert or block **214** that may be used to guide drill bits, or pins, among other tools, may be inserted into the working cannula **212**. The drill guide insert **214** may guide a drill bit along predetermined paths in order to remove tissue from the articular portion of the sacroiliac joint. FIG. 10B illustrates a first drill guide block **214** with a single through-bore. Once inserted into the working cannula **212**, a drill bit **222** of a drill assembly, may be inserted through the drill guide

block to remove tissue from within the articular portion of the joint. Guide block standoffs may be used as part of the system described herein to control the depth to which tools are inserted into a patient. Such standoffs may be used, for example, in conjunction with the drill guide blocks to control the insertion depth of the drill assembly.

In certain implementations, multiple drill guide blocks may be used to guide the drill bit of the drill assembly to various locations to remove additional tissue. Following removal of tissue from the articular portion of the sacroiliac joint, the exposed bone may subsequently be prepared for implantation of a joint implant. In certain implementations, such a process generally includes cutting away or otherwise removing cortical bone and filing the exposed bone to bleeding bone in order to promote healing and bone growth over the joint implant. To facilitate such procedures, the system disclosed herein may also include a tool guide block shaped to fit within the tissue protector when inserted through the open proximal end of the tissue protector.

As illustrated in FIGS. 11A-11C, the tool guide block **224** in FIG. 11B generally includes a block-like structure defining a longitudinal passageway through which tools may be inserted. Such tools may include, without limitation, osteotomes, rasps **226** (as seen in FIG. 11C) or similar tools to further prepare the joint for fusion or delivery tools for delivering the joint implant to the implantation location. The longitudinal passageway may be shaped to allow only substantially longitudinal movement of corresponding tools shaped to be inserted into the longitudinal passageway. For example, in the illustrated implementation, the longitudinal passageway of the tool guide block has a cross-sectional shape defining a passageway that is substantially "I"-shaped but with an additional midline cross-bore through the "I" shape. This cross-sectional shape substantially matches that of various tools so as to prevent the tools from rotating within the tool guide block and within the joint.

With respect to further preparation of the sacroiliac joint, such tools may include an osteotome, a starting rasp, and a finishing rasp. Each of the osteotome, the starting rasp, and the finishing rasp may have longitudinal bodies having projections such that the cross-section of the longitudinal bodies substantially matches the passageway of the tool guide block.

Following preparation of the articular surfaces, a broach may be used to cut slots into the surfaces for receiving keels or other features of the joint implant. To do so, a broaching assembly may be used in conjunction with the tool guide block to cut the keel slots.

After formation of the keel slots, an additional procedure may be undertaken to remove tissue by additional drilling. Accordingly, the system may further include each of a keel drill assembly and one or more keel guide blocks corresponding to locations in which additional tissue or bone is to be removed. The keel guide blocks may include longitudinal bores distributed in a predetermined pattern and at predetermined distances relative to each other in order to guide the keel drill assembly to the necessary locations within the implant receiving space. In certain implementations, the system may include a range of keel guide blocks, each of which having progressively larger or more spaced apart longitudinal through-bores.

FIGS. 12A and 12B depict the joint implant **200** coupled to the implant arm **204**, and delivered into the sacroiliac joint. As seen in FIG. 12A, the implant arm **204** extends through the working cannula **212**, which is supported in place by the pins **225** generally extending into the joint at the PSIS and PIIS, respectively.

Further details of an example joint implant **200** are illustrated in FIG. 12B. The example joint implant **200** includes each of a planar top member **228** and a planar bottom member (also referred to herein as keels) **228**, a distal member **230** connecting a distal portion of the top and bottom members **228**, and a proximal member **232** connecting a proximal portion of the top and bottom members **228**. The joint implant **200** further defines a transverse passageway **234** between the distal and proximal members **230**, **232** for receiving an anchor or biocompatible material.

In certain implementations, biocompatible material may be disposed within the joint implant **200** using a bone injection block and associated tools for packing the transverse passageway **234**.

Following placement of the joint implant within the implant receiving space, an anchor may be delivered transversely to or across the joint to additionally stabilize the joint.

#### B. Second Embodiment of a Delivery Tool, Insertion Tools, and a Joint Implant

Reference is made to FIGS. 13-17 in the present application. An exemplary embodiment of a joint implant **300** may be seen in FIG. 13. As seen in the figure, the joint implant **300** includes a pair of keels or planar members coupled together at a distal end by a distal intra-articular or connecting member, and coupled together at a proximal end by a proximal intra-articular or connecting member. In certain embodiments the planar members are only coupled together at the distal end either by a proximal intra-articular member or at a proximal end without any intra-articular member such that the implant resembles a staple having wide planar legs. Each of the pair of keels may be a mirror image of each other. The pair of keels may include inner surfaces or faces that face each other, and outer surfaces or faces that are opposite each other. The inner and outer faces of the pair of keels may be bounded by a tapered distal edge, lateral side edges that may be jagged, serrated, or saw-like, and a linear proximal edge. The pair of keels may include a plurality of passageways that extend from the outer surfaces to the inner surfaces. The inner surfaces of the keels may taper towards each other at the proximal end and may include a series of ridges or serrations that inhibit migration of the implant once it is implanted in the sacroiliac joint. The distal intra-articular member may be tapered at the distal tip so as to ease insertion into the sacroiliac joint.

The proximal end of the joint implant includes a tool interface that includes an elongated slot defined in a proximal side of the proximal intra-articular member. The tool interface may be used in conjunction with a distal end of an implant arm of a delivery tool to couple the joint implant and the implant arm together. As seen in FIG. 93 of U.S. 62/609,095 filed Dec. 21, 2017 and hereby incorporated by reference in its entirety, the tool interface defines a rectangular perimeter on the proximal end of the joint implant. The top and bottom portions of the rectangular perimeter define lipped edges for supporting a portion of an implant arm, which will be subsequently described in more detail.

As seen in the longitudinal cross-sectional view of FIG. 14, and moving distally from a proximal most boundary, the lipped edges of the tool interface includes a proximal facing ramped portion that ramps inwardly to a planar longitudinal portion. The planar longitudinal portion transitions to a distal facing ramped portion. The distal faced ramped portion transitions to another planar longitudinal portion, which then transitions to a proximal facing planar portion. The proximal facing planar portion is perpendicular to the planar longitudinal portion. Central within the proximal facing

planar portion is a rectangular opening and a passageway that extends into a window or opening defined between the inner ends of the proximal intra-articular member and the distal intra-articular member. As seen in the cross-sectional view of FIG. 14, the window is pill shaped with arcuate ends defined by the ends of the proximal intra-articular member and the distal intra-articular member, and planar, parallel sides defined by the inner sides of the pair of planar members.

In certain instances, the joint implant may be implanted, inserted, or delivered into the sacroiliac joint such that the intra-articular members are positioned generally within the plane of the sacroiliac joint, and the planar members extend across the joint and into the sacrum and the ilium.

The delivery tool **302** may include an implant arm **304** (alternatively called an insertion arm) and an anchor arm **305** extending off of the implant arm **304**. As seen in FIG. 15, the implant arm **304** may include a distal member **306**, a proximal member **308**, and an intermediate member **310**. A cylindrical proximal end of the intermediate member may be fitted through a tubular portion of the anchor arm, and the proximal member may couple to the cylindrical proximal end of the intermediate member to couple the implant arm to the anchor arm.

The proximal member **308** includes a distal opening for receiving the proximal cylindrical end of the intermediate member **310**. The distal opening is defined in a cylindrical body. And coupled to the cylindrical body is an attachment rod terminating in a large Hudson connection configured to attach to a handle extending away from a cylindrical sidewall of the cylindrical body. A lumen extends through the cylindrical body, and is coaxial with the distal opening.

The intermediate member **310** can be seen in FIG. 15, and it includes the cylindrical proximal end, and a rectangular tube that extends distally from the cylindrical proximal end. A pair of fins extend outward from the long sides of the rectangular tube, and also extend a length of the rectangular tube. A lumen extends through the intermediate member from the cylindrical proximal end to the distal end of the rectangular tube. The lumen of the intermediate member **310** is coaxial with the lumen of the proximal member **308** such that tools and material (e.g., biocompatible material) may be passed through the pair of lumens.

A pair of prongs extends distally out of the distal opening of the rectangular tube. The pair of prongs are positioned at opposite ends of the distal opening (i.e., the short ends of the rectangular tube). The pair of prongs is configured to couple the intermediate member **310** to the distal member **306**.

The distal member **306** includes a pair of distally extending prongs that are coupled at a proximal end to a plate. At a distal end of each of the prongs are laterally extending wings. The wings are positioned such that they generally lie in the same plane as the pair of planar members of the joint implant when the distal member is coupled to the joint implant. The wings may be dimensioned such that the height is less than the height of the planar members of the implant such that when the distal member disengages the implant and are deflected towards one another they will still fit within the track cut into the bone the implant followed.

The pair of prongs are spaced-apart from each other and are open at the distal end. At a proximal end of the distal member, the distal member forms a semi-cylindrical outline on a distal side of the plate and in between the prongs. This shape may permit the prongs to flex inward and extend outward away from each other so as to couple and uncouple with the joint implant. The plate includes a lumen extending longitudinal there through that is coaxial with the lumens of



the intermediate member and the proximal member. In this way, tools can be inserted through the respective lumens of the proximal member, intermediate member, and distal member, and also inserted into the window of the joint implant via the passageway within the tool interface. Such insertion of the tool can be accomplished while the implant arm is coupled to the joint implant because the lumens are centrally positioned, and the coupling of the joint implant and the distal member avoids obstructing the lumens.

Each of the prongs includes a tab that extends distally off of its respective prong. The tabs are configured to selectively engage and release the tool interface of the proximal end of the joint implant **300**.

In certain instances, a neutral condition (i.e., unstressed state, unflexed) of the distal member **306** may be when the prongs are parallel with each other. In the neutral position, the prongs may be flexed inward towards each other, via an applied force, in order to permit the tabs to fit within the tool interface opening. Once the tabs are within the tool interface opening, the prongs may rebound or expand back to the neutral position. Once coupled with the joint implant **300**, the distal member **306** may be configured such that it exerts opposing forces on the joint implant so as to ensure a secure connection between the joint implant and the distal member.

In certain instances, a neutral condition (i.e., unstressed state, unflexed) of the distal member **306** may be when the prongs are non-parallel with each other. In an example, the neutral condition may be when the prongs converge towards each other. As will be discussed subsequently, a tool (e.g., engagement tool) may be used to forcibly move the prongs to a parallel condition so as to secure the connection between the joint implant and the distal member. The tool may then be removed, after implantation of the joint implant, in order to decouple the joint implant and the distal member. In another example, the neutral condition may be when the prongs diverge away from each other each other in a non-parallel condition. A tool (e.g., engagement tool) may be used to flex the prongs to a less than parallel condition so as to permit coupling of the joint implant and the distal member. Once coupled, prongs of the joint implant may exert a force on the joint implant by attempting to expand back to its neutral state. After implantation of the joint implant, the tool may be used again to decouple the joint implant and the distal member.

FIGS. 15-16 show various types of insertion tools that may be used in conjunction with the implant arm **304**. To begin, a solid or non-cannulated engagement tool (not shown) for inserting through the implant arm **304** is shown in FIG. 15. The engagement tool includes a cylindrical section at a proximal end (optional male threads not shown), and an elongate member with a rectangular cross-section extending distally from the cylindrical section. The cylindrical section may include a sealing flange at a proximal most point. There is no lumen extending through the non-cannulated engagement tool. The engagement tool may be advanced through a lumen of the arm knob such that the sealing flange is received within and seals relative to the lumen of the arm knob. A ring clip may be used to secure an arm knob onto the cylindrical section positioned adjacent and distal to the sealing flange thereby fixing the location of the arm knob on the engagement tool while allowing the arm knob to rotate freely around the cylindrical section. In particular, the clip may snap into a cylindrical groove near the distal end of the cylindrical section thereby allowing the threading of the arm knob into the recess of the body proximal part of the insertion tool (optional female threads not shown) via rotational forces while allowing the rectan-

gular volume of the engagement arm to not rotate yet still translate along the length of the insertion tool.

The length of the elongate member of the engagement tool is such that it may be received up to the distal end, and in between, the prongs of the distal member **306** so as to restrict the prongs from flexing inward towards each other. Thus, the engagement tool may ensure a secure connection between the joint implant and the distal member of the implant arm, for example, during delivery of the joint implant into the sacroiliac joint. Upon delivery, the engagement tool may be retracted from the implant arm to permit decoupling of the joint implant from the implant arm.

Moving on to another insertion tool, a cannula insertion tool **312** for inserting through the implant arm is shown in FIGS. 15-16. The cannula insertion tool **312** includes a cylindrical section at a proximal end (optional male threads not shown), and a tubular member with a rectangular cross-section extending distally from the cylindrical section. The cylindrical section may include a sealing flange at a proximal most point. The cylindrical section may include a proximal opening at the proximal end that is larger than the lumen of the tubular member, which extends from within the cylindrical section to a distal opening at the distal end of the tubular member. The proximal opening at the proximal end opens up to a female threaded bore within the cylindrical section configured to receive the luer lock adapter described below. The cannula insertion tool **312** may be advanced through a lumen of the arm knob such that the sealing flange is received within and seals relative to the lumen of the arm knob. A ring clip may be used to secure an arm knob onto the cylindrical section. In particular, the clip may snap into the cylindrical groove near the distal end of the cylindrical section. Generally, the arrangement between the cylindrical section and the arm knob are the same as described above for the engagement tool. The coupled arm knob and cannula may then be inserted through the lumens of the implant arm's proximal member, intermediate member, and distal member. When received therein, the arm knob may be engaged with the proximal end of the cylindrical body of the proximal member.

A luer lock adapter may be inserted, external threads first, into the female threaded bore of the cylindrical section, and a syringe may be engaged with the opposite end of the luer lock adapter. Thus, the luer lock adapter provides a fluid connection to the implant through the tubular member of the cannula insertion tool for the dispensing of biological material therein. Alternatively, a funnel may be engaged with proximal opening of the cannula insertion tool for the dispensing of biological material therein. The funnel may have a male threaded defined on the exterior tip of the nozzle of the funnel configured to thread into the female threaded bore of the cylindrical section. Another insertion tool that may be used in conjunction with the cannula insertion tool **312** is a tamp insertion tool **314**, which is shown in FIGS. 15 and 16. The tamp insertion tool **314** may include a cylindrical body at a proximal end and a thin elongate member with a rectangular cross-section extending from the cylindrical body. The elongate member may be configured to be inserted within the tubular member of the cannulated insertion tool **312** via the proximal opening at the proximal end of the cylindrical section (after the luer lock has been removed) so as to advance material (e.g., biological material such as bone paste, bone graft, etc.) through the tubular member of the cannula insertion tool **312**, and deposit the material through the lumen within the tool interface of the joint implant **300** and into the window of the joint implant **300**. As such, the size of the elongate member may be sized

to fit just within the passage of the tubular member so as to act like a plunger within a syringe in moving the material through the cannula insertion tool to the joint implant.

FIG. 17 shows an isometric view of the distal member and the joint implant uncoupled from each other. As seen in FIG. 17, the distal member is aligned with the joint implant in a way that the tabs at the distal end of the prongs will be received within the tool interface of the joint implant when the distal member and the joint implant converge. In this particular orientation, the distal member is in a neutral condition where the prongs are generally parallel to each other. The distal member may be distally advanced relative to the joint implant and the tabs may engage and be secured to the tool interface portion of the joint implant because of the complimentary geometry of the tabs and the tool interface.

As seen in FIG. 16, which is a longitudinal cross-sectional views along a plane that is parallel to a plane of the planar members of the joint implant, the distal end of the tubular member of the cannula insertion tool 312 abuts against the proximal facing planar portion of the tool interface. In this fully distal position, the geometry on the inside of the tubular member matches the geometry of the passageway through the tool interface and into the window of the joint implant 300.

FIG. 16 also depicts the tamp insertion tool 314 being inserted within the cannula insertion tool 312 so as to distally advance the biological material within the tubular member and into the window of the joint implant 300. As seen in FIG. 16, the tamp insertion tool is partially advanced so as to be about halfway along a length of the distal member. Note the biological material is not shown in FIG. 16.

FIG. 17 depicts the uncoupling of the joint implant 300 from the distal member 306 following insertion of the biological material into the window of the joint implant 300. To accomplish the uncoupling, the tamp insertion tool 314 and the cannula insertion tool 312 may be retracted; then, the implant arm 304 may be proximally pulled relative to the joint implant 300, which is securely implanted within the joint. The complementary geometry of the tabs of the distal member and the lipped edges of the tool interface may permit such decoupling merely by providing an opposing force between the distal member and the joint implant. And without the tubular member of the cannula insertion tool positioned within the distal member 306, the prongs may be permitted to flex inward to permit the uncoupling.

A kit comprising the aforementioned tools or implant may further include a particular volume of biological material which approximately corresponds to the volume of the bone graft window of the implant. Optionally, the particular volume may significantly exceed the volume of the bone graft window such that the bone graft window of the implant may be filled and then flow out into the joint space adjacent the implant via openings in the planar members.

### III. Radiographic Tools for Use During Preparation for Fusion of the Sacroiliac Joint

As described in previous sections, implantation of a joint implant for fusion of the sacroiliac joint includes preparation of a joint receiving space. Such preparation includes removing articular cartilage; removing cortical, subchondral or cancellous bone of the joint (such as by cutting or abrading the joint surfaces); and then cutting slots, drilling holes, or similar features into the exposed boney tissue to receive keels or other structural elements of the joint implant. Once prepared, the joint implant is delivered into the prepared joint space and one or more anchors are delivered across the

joint and into the ilium and sacrum. Additional anchors may also be implanted to provide additional stability of the treated joint. Implantation of the anchors may also include preparation of the corresponding screw holes such as by drilling pilot holes or removing additional tissue within or surrounding the anchor implantation locations. Notably, many of the procedures for preparing the implant receiving space materially affect the sacrum and/or ilium such that misplacement of the anchors may not be readily correctable. In light of the foregoing, systems in accordance with this disclosure may include a radiographic guidance system 400 configured to allow a surgeon to evaluate and confirm implant trajectories, implant configurations, implant sizes, screw (or other anchor) trajectories and screw lengths prior to preparing the screw holes.

The radiographic guidance system 400 includes a trial implant 402 that is coupled to the distal end of an implant arm of a delivery tool. The trial implant 402 may be disposed within the implant receiving space of the joint prior to fully preparing the articular surfaces of the sacrum and ilium. By doing so, the trial implant 402 may be used to assess and verify the placement of the final joint implant prior to substantial alteration of the articular surfaces.

An example of a trial implant 402 is shown in FIG. 18. As shown, the trial implant 402 generally conforms to the size and shape of the joint implant 300, of FIGS. 13-17, among others, used to actually fuse the sacrum and ilium but lacks the keels of the joint implant 300. Accordingly, the trial implant 402 can be disposed within the joint space prior to forming the slots or grooves of the implant receiving space required to receive the keels of the joint implant 300.

The trial implant 402 may include a body formed from a radiolucent material (such as PEEK or Radel) with radiopaque markers 404 coupled to or disposed within the body. For example, the trial implant 402 in FIG. 18 includes pins 404 formed of a radiopaque material (such as tantalum or titanium) and that are inserted into the radiolucent body at the distal tip, and upper and lower distal corners. In other implementations, the radiopaque markers 404 may instead be in the form of, among other things, beads, bands, rings, or strips disposed within or coupled to the body of the trial implant 402. The radiopaque markers 404 may be disposed at various locations of the trial insert including, without limitation, at corners of the trial implant 402, along the outer perimeter of the trial implant 402, along a bone graft window perimeter of the trial implant 402, at a centroid of the trial implant 402, or at or along any other feature of the trial implant 402.

The trial implant 402 may be delivered into the sacroiliac joint using the same delivery tool for delivering the joint implant as previously described, as described below regarding any implant coupling instrument or a dedicated (e.g., radiolucent Radel) shaft may be removably or permanently coupled (either multi-piece construction or constructed from a single piece of material) with the trial implant. As illustrated in FIGS. 19-20, the delivery tool 406 may include an implant arm 408 having a distal end to which the trial implant 402 is coupled and inserted into the sacroiliac joint. Guide pins, tissue protectors, and other components that may be used in conjunction with the delivery tool are omitted from FIGS. 19-20 for clarity. During placement of the trial implant 402, multiple x-rays or similar images may be taken to determine the location and orientation of the trial 402 and other components of the radiographic guidance system. Such images may include, without limitation, one or more views including, an anteroposterior view, a lateral view, an inlet view, an outlet-oblique view, Judet views of

the pelvis, an internal (obturator) oblique view, a Ferguson view, an external (iliac) oblique view, or other relevant views.

The features used to align or otherwise position the radiopaque markers of the guidance system may include, without limitation, structural elements of the trial implant (such as a centroid of the trial implant, or a radiopaque marker of the trial implant) or anatomical features of the patient. An anatomical feature may, for example, be a portion of the outer cortex of the ilium corresponding to the location of the anchor head once implanted. Other anatomical features of the ilium or sacrum or radiographic bony landmarks that may be used as references for aligning the radiopaque markers of the guidance system include, without limitation, the superimposed greater sciatic notches, the superimposed iliac cortical densities or alar slope, the sacral promontory, the first sacral endplate, the sacral foramina, the arcuate sacral lines, the iliopectineal line, the ilioischial line, the acetabular teardrop lines bony corridors of S1 or S2, the superimposed acetabula, and the ventral and dorsal surfaces of the sacrum. Anatomical features may also include vascular structures, which may be identified using an angiogram or similar imaging system. Examples of such vascular structures include, without limitation, the superior gluteal artery, the internal iliac artery and vein, and the iliolumbar vein.

Placement of the trial insert **402** may be facilitated and/or verified using a radiographic guidance system **400** inserted into or otherwise coupled to the delivery tool **406**. In certain aspects, the radiographic guidance system **400** may be inserted into or otherwise coupled to the working cannula **506** (also referred to as a tissue protector), the implant arm **504**, the anchor arm **508** (also referred to as an angle arm) or the anchor block **510** of the embodiment shown in FIGS. **23-26** and described below or the similar systems described and shown throughout the rest of the present application or any of the referenced applications. In FIGS. **19-20**, for example, the radiographic guidance system **400** is disposed within an anchor arm guide **410** of the delivery tool **406**. The radiographic guidance system **400** includes various members that are substantially composed of radiolucent materials. Similar to the trial insert **402**, the members of the guidance tool may also include radiopaque markers, such as beads, at predetermined locations that may be used to verify placement of the trial insert.

With reference to FIGS. **19-20**, the guidance system **400** includes a guide arm **412** adapted to receive each of a plunger **414** and a collet **416**. The collet **416** is adapted in turn to receive a cylindrical depth gauge **418** that may be translated within the collet **416**.

The depth gauge **418** includes an elongate body within which radiopaque markers are disposed. For example, the depth gauge **418** may include at least one proximal marker **420** used to facilitate alignment of the depth gauge with radiopaque features of other components of the guidance system or anatomical features. A distal end of the depth gauge may include multiple radiopaque markers **422** disposed at predetermined intervals or otherwise disposed in a predetermined graduated pattern to facilitate taking measurements or evaluating distances using the depth gauge. According to particular alternative embodiments, depth gauge **418** and/or elongated plunger **426** may be constructed entirely or largely from radiopaque materials, e.g., stainless steel and may simply be a Steinmann pin or K-wire.

Referring to FIGS. **19-20**, the guidance system **400** is coupled to the delivery system **406** by inserting the plunger **414** into an anchor arm guide **410** of the delivery system

**406**. Once inserted into the delivery system **406**, the guidance tool may be adjusted by rotating the guide arm **412** of the guidance system within the anchor arm guide **410** and/or translating the depth gauge **418** within the collet **416**.

A surgeon may align each of a radiographic system (e.g., fluoroscopy machine and the x-ray beam) **424**, radiopaque markers **404** of the guidance system **400**, and a feature of the trial implant **402** or anatomical feature. Such alignment is generally achieved by manipulation of the guidance system **400** (such as by rotation within the anchor arm guide or translation of the depth gauge) and/or repositioning of the radiographic system **424**. When such alignment occurs, the radiopaque markers **420**, **422** of the depth gauge **418** may be used to verify placement and orientation of the trial implant **402** and to measure distances between the trial implant **402** and anatomical features, among other things.

Once the trial implant is satisfactorily placed, an alternative radiographic guidance system may be used to verify or determine anchor placement, as illustrated in FIGS. **21-22**. As illustrated, the guidance system **400** includes an elongated plunger **426**, adapted to be inserted through the anchor arm guides **410** of the delivery tool **406** such that a distal end of the elongated plunger **426** reaches the corresponding anchor implantation location associated with the guide hole within which it is inserted. The guidance system **400** further includes a guide arm **412** and a depth gauge **418**, where the guide arm **412** is coupled between the depth gauge **418** and the elongated plunger **426**.

As illustrated in FIG. **20**, the surgeon may align the depth gauge **418** of the guidance system **400** with each of a radiographic system **424** (e.g., emitter and detector of a fluoroscopy machine) and the elongated plunger **426** such that each are generally aligned in the same plane. By doing so, the radiopaque markers of the depth gauge **418** extend along an anchor trajectory that is visible in the corresponding radiographic image. In addition to indicating the trajectory of the anchor, the radiopaque markers of the depth gauge **418** may be used to determine the depth to which an anchor may be delivered, the distance between the anchor and any surrounding anatomical features, and other dimensions relevant to placement of the anchor.

In one example implementation, alignment may be achieved by aligning in the radiographic image a proximal most radiopaque marker **420** of the depth gauge **418** such that it overlays a proximal radiographic marker **428** of the elongated plunger **426** either by rotating and/or translating certain parts guidance system or by adjusting the location and orientation of the beam of the radiographic system **400**.

#### IV. Additional System for Preparing the Sacroiliac Joint for Fusion

Reference is made to FIGS. **23-26** for a discussion of a sacroiliac joint access, preparation and delivery system **500**. FIG. **23** is a distal isometric view of a portion of the components of the system **500**. FIG. **24** is a proximal isometric view of the components of the system **500** of FIG. **23**. FIG. **25** is an isometric side view of the components of the system **500** of FIG. **23**. And FIG. **26** is a side view of the components of the system **500** of FIG. **23**, with a joint implant **502** coupled to an implant arm **504** of the system **500**.

The preparation and delivery system **500** may include a working cannula **506** (also referred to as a tissue protector), the implant arm **504**, the implant **502**, an anchor arm **508** (also referred to as an angle arm), an anchor block **510**, a pin **512** (also referred to, or may be configured, as a Schanz screw, Steinmann pin, Kirschner wire or K-wire), a guidance pin **514** (also referred to, or may be configured, as a Schanz

screw, Steinmann pin, Kirschner wire or K-wire), an anchor **516**, and a standoff **518** (also referred to as an insert), among other components not shown in FIGS. **23-26**, but shown in subsequent figures.

As seen in FIGS. **23-26**, the working cannula **506** connects to the anchor arm **508** at a proximal end **520** thereof. The anchor arm **508** is cantilevered off of the working cannula **506**, and is generally angled about at a ninety degree bend. The anchor arm may have numerous different configurations similar to those shown and described in the referenced patent applications or as otherwise described throughout the present application (e.g., having an arcuate bend, various shapes and angles, tubular, telescoping, fixed, adjustable, pivotable, slidable, translatable, rotatable, bendable, indexable, multisegmented, customizable etc.) modified to couple with the working cannula versus the implant arm. The anchor block **510** may be removably coupled to the free end of the anchor arm **508**, and may include superior guide holes **522**, inferior guide holes **524**, and superior-inferior slots **526** extending through the anchor block **510**. The superior guide holes **522** may guide a pin **512** in a predefined trajectory relative to the joint implant **502** that is superior to the joint implant **502**. The inferior guide holes **524** may guide a pin **512** in a predefined trajectory relative to the joint implant **502** that is inferior to the joint implant **502**; or alternatively, when the working cannula and other instruments are flipped approximately 180 degrees to align with the contralateral sacroiliac joint, inferior guide holes **524** may guide a pin **512** in a predefined trajectory relative to the joint implant **502** that is superior to the joint implant **502**. The superior-inferior slots **526** may orient a cutting tool or other tool in-line with or adjacent the joint implant **502** while allowing a limited range of trajectories. The anchor block **510** in FIGS. **23-26** generally orient pins and tools perpendicular to the longitudinal axis of the joint implant **502**; however, the system **500** may include additional or alternative anchor blocks **510** with guide holes and slots that orient the pins **512** and anchors **516** at different trajectories relative to the joint implant **502**.

The pins **512** may guide the delivery of the anchor **516** into the bones of the sacrum, the ilium, and the sacroiliac joint in a transverse orientation relative to the joint implant **502**. As seen in the figures, the anchor **516** may include a longitudinal lumen **528** for the pin **512** to extend there through. In this way, the pin **512** may provide an initial path to the bone, and the anchor **516** may be delivered along the trajectory of the pin **512**. Upon delivery of the anchor **516** into the bone, the pin **512** may be withdrawn.

The guidance pin **514**, e.g., a Schanz screw, may be anchored to the patient's bone, and the pin **514** may be secured in position relative to the working cannula via a screw lock **530**. As an example, the guidance pin **514** may be anchored to the portion of the patient's posterior superior iliac spine that extends medially over the posterior access region of the sacroiliac joint. In this way, the working cannula **506** is oriented to guide tools and implants into the articular region of the sacroiliac joint, which is inferior to the portion of the posterior superior iliac spine to which the pin **514** is anchored.

The following discussion is with reference to FIGS. **27-38**, which depict various views of the components of the preparation and delivery system **500**. To begin, FIGS. **27A-27D** are respectively isometric, top, side, and front views of a joint finder **532**. As seen in the figures, the joint finder **532** may include an elongate body **534** with spatulate tip **536** at a distal end **538** thereof, a transverse opening **540** extending between sides of the body **534**, a rectangular block-like

handle **542** at a proximal end **544**, and a recessed gripping portion **546** just distal of the block-like handle **542**. The spatulate tip **536** may be used to identify the opening or gap between the sacrum and the ilium. Upon identifying the opening or gap between the sacrum and ilium, the spatulate tip **536** may be advanced into the sacroiliac joint.

FIGS. **28A-28D** are respectively isometric, top, back, and side views of a working cannula or tissue protector **506**. The working cannula **506** may include a pair of prongs, spikes, or projections **548** at a distal end **550** thereof, a tubular body **552** extending proximally from the pair of prongs **548**, and a pair of anchor arm engagement structures **554** at the proximal end **520**. Within the working cannula **506** is a passageway **556** that extends from the proximal to distal ends **520**, **550**. An inner surface **558** of the passageway **556** is keyed in the shape of an I-beam or H-beam.

As particularly seen in FIG. **28A**, a portion of the inner surface **588** of the passageway **556** at the proximal end **520** is keyed so as to accept a standoff and has a keyed configuration which is different from the keyed passageway discussed above, in particular the proximal end is keyed with a generally square shape with two opposing corners having a substantial radius compared with the other two corners having a comparably small radius, and the tubular body **580** of the standoff has a cross section along a portion of the length of the standoff which matches the shape of the proximal end **520** where the cross section of the tubular body includes a generally square shape with two opposing corners having a substantial radius compared with the other two corners having a comparably small radius, in order to properly align the keyed inner surface **590** of the standoff **578** with the keyed inner surface **588** of the passageway **556**, the standoff will be discussed in further detail below in reference to FIGS. **30A-30D**. That is, the inner surface **558** of the passageway **556** comprises two differently configured keyed portions which ultimately result in a continuous keyed passageway once the standoff is in position within the proximal end of the working cannula.

The working cannula **506** may additionally include a pin guide **592** and a screw lock **530** at the proximal end **520**. The pin guide **592** may be a cylindrical passageway that aligns an axis of a guide pin positioned therein (shown in FIG. **23**, for example) in parallel alignment with a longitudinal axis **594** of passageway **556** of the working cannula **506**. The guide pin may be secured in position relative to the working cannula **506** by tightening a screw lock **530**. As seen in FIGS. **28A-28D**, the pin guide **592** is positioned on a superior side of the working cannula **506** so as to guide a guide pin into a portion of the ilium (e.g., posterior superior iliac spine) while aligning the longitudinal axis **594** of the passageway **556** of the working cannula **506** with the articular region of the sacroiliac joint. The pin guide **592** is positioned between the anchor arm engagement structures **554**, which are on opposite sides of the working cannula **506**.

According to particular embodiments, the pin guide may have a fixed configuration such that the trajectory of the guide pin positioned therethrough is not adjustable or the pin guide may have an adjustable configuration such that the trajectory of the guide pin positioned therethrough is adjustable in at least one plane in order to align the guide pin with the desired boney anatomy without necessitating the reorientation or position of the working cannula longitudinal axis. For example, the pin guide may swivel (reversibly lockable) relative to the rest of the working cannula in order to allow the guide pin to be angled either lateral or medial to the longitudinal axis of the working cannula or even

closer to or further away from (e.g., cranial or superior to) the exterior of the working cannula. As another example, the pin guide may translate (e.g., along a track and reversibly lockable) relative to the rest of the working cannula in order to allow the guide pin to be positioned either lateral or medial to the longitudinal axis of the working cannula or even closer to or further away from (e.g., cranial or superior to) the exterior of the working cannula. According to yet further embodiments, the pin guide may be couple to the working cannula with various mechanisms and arrangements that provide various desirable degrees of freedom.

The anchor arm engagement structures **554** may include a T-slot **596** formed by a pair of longitudinally extending tabs **598**. The T-slot **596** may receive a corresponding structure of the anchor arm **508** having a T-shaped end portion.

According to certain aspects, the anchor arm engagement structures **554** may include a dovetail slot **596** formed by a pair of longitudinally extending tabs **598**. The dovetail slot **596** may receive a corresponding structure of the anchor arm **508** having a dovetail shaped end portion. Whether the anchor arm engagement structures **554** and corresponding structure of the anchor arm **508** have a T-shaped, dovetail shape or an other similar arrangement the female portion may be defined on the working cannula (as shown) or alternatively the male portion may be defined on the working cannula and the female portion on the anchor arm.

FIGS. **29A-29D** are respectively isometric, top, back, and side views of a depth gauge **560**. As seen in the figures, the depth gauge **560** may include an elongate body **572** with a thin elongate tongue **562** at a distal end **564** thereof. The depth gauge **560** may include a rectangular block-like structure **566** at a proximal end **570** thereof. The structure **566** may include a series of markers **568** indicating a depth or distance away from the distal tip **570** of the tongue **562** or from a different component of the preparation and delivery system **500**. The markers **568** may include numerical markers (indicating, for example, millimeters or centimeters, among other units of measurement) and/or physical markers (e.g., indentations in the block-like structure **566**) to indicate a depth or distance. For example, the desired depth of implant receiving space preparation or other joint preparation, or implantation depth may be determined by reading the laser marking on the depth gauge from the proximal most surface of the working cannula once the thin elongate tongue is positioned in the sacroiliac joint at a desired location and orientation (e.g., as shown in FIG. **77**) in order to select the appropriate corresponding standoff size.

The elongate body **572** may further include an intermediate section including a pair of members **574** interconnected between the block-like structure **566** and the tongue **562**. The structure **566** may include a threaded bore **576** at the proximal end **570** for threadably coupling to a button knob having a male end thread.

FIGS. **30A-30D** are respectively isometric, top, back, and side views of a standoff or insert **578**. The standoff **578** may include a tubular body **580** and a flanged base **584** extending outward from the tubular body **580** at a proximal end **582** of the standoff **578**. The tubular body **580** extends to a distal end **586** of the standoff **578**. As seen in FIGS. **30A-30B**, and **30D**, the flanged base **584** may include beveled edges **588** along two edges thereof. As seen in FIG. **30C**, an inner surface **590** of the standoff **578** is keyed in the shape of an I-beam or H-beam so as to match the inner surface **558** of the passageway **556** of the working cannula **506** when the standoff **578** is positioned within the proximal end **520** of the passageway **556** of the working cannula **506**. Once posi-

tioned in the working cannula **506**, the keyed inner surfaces **590** of the standoff **578** and the inner surface **558** of the working cannula **506** are flush, collinear, or planar with each other.

While the inner surface **590** of the standoff **578** and the inner surface **558** of the passageway **556** of the working cannula **506** may be keyed in a corresponding shape of the joint implant of an I-beam or H-beam, the inner surfaces **590**, **558** may be modified to fit a particular shape a joint implant **502** to be implanted. For example, the inner surfaces **590**, **558** of the standoff **578** and working cannula **506** may be keyed to an X-shaped cross-section (among other shapes) to permit the joint implant **502** and associated tooling to extend there through. Additionally, other tools described herein may similarly be modified to permit passage through inner surfaces that are keyed to an X-shaped cross-section. For instance, joint preparation tools may similarly be modified to prepare the joint space for the implantation of an implant of a particular shape. In the instance of an X-shaped implant **502**, a broach may similarly include a cutting surface shape that matches the X-cross-sectional shape of the joint implant **502**.

The depth gauge **560**, for example, may be used in conjunction with the working cannula **506**. The depth gauge **560** may be inserted in the working cannula **506** such that the tongue **562** is oriented vertically. In this orientation, the width of the depth gauge **560** is slightly smaller than a distance between the inner protrusions of the inner surfaces **558** of working cannula **506**.

FIGS. **31A-31D** are respectively isometric, top, back, and side views of a drill guide insert **600**. As seen in the figures, the drill guide insert **600** may include a tubular body **602** having a rectangular cross-section transverse to its length, a flanged base **604** extending outward from the tubular body **602** at a proximal end **606** thereof, and a series of cylindrical guide holes **608** extending longitudinally through the insert **600** from the proximal end **606** to a distal end **610** thereof. As seen in FIGS. **31A** and **31C**, the drill guide insert **600** includes three guide holes: a superior guide hole; a central guide hole; and an inferior guide hole. In certain instances, the drill guide insert **600** may include a different number and arrangement of guide holes. The drill guide insert **600** as shown herein is designed to align a drill bit along a plane of the sacroiliac joint. When the drill guide insert **600** is positioned within the standoff **578** and the working cannula **506**, the series of guide holes **608** are aligned in a plane with the pair of prongs **548** of the working cannula **506**.

FIGS. **32A-32B** are respectively isometric and side views of a drill bit **612**. The drill bit **612** may be sized to fit within the cylindrical guide holes **608** of the drill guide insert **600**, and sized to drill out a portion of the articular surfaces of the sacrum and ilium in preparing the sacroiliac joint for a fusion procedure. The drill bit **612** may include a drill engagement structure **614** at a proximal end **616** thereof for coupling to a surgical drill (not shown) or quick connect handle. Additionally, the drill bit **612** may include cutting surface (e.g., flutes) **615** at a distal end **617** thereof. As an example, the drill diameter of the fluted portion may be equal to or less than the diameter to the shank diameter proximal to the fluted portion, and either an adjustable or non-adjustable and fixed (as shown in FIGS. **32A-32B** as an increase in diameter of the shank/shaft of the drill bit) drill stop is located between the proximal end **616** and distal end **617** configured and calibrated (and positioned a similar distance with the stops, flanged bases **624/650**, of the other

tools relative to their distal cutting ends) in order to abut the proximal surface of the standoffs to limit the depth of cutting.

FIGS. 33A-33D are respectively isometric, top, back, and side views of a box osteotome 618. As seen in the figures, the box osteotome 618 may include a four-sided tubular cutting structure 620 at a distal end 622 of the box osteotome 618. A flanged base 624 is at a proximal end 626 of the box osteotome 618, and an elongate intermediate section 628 interconnects the flanged base 624 and the tubular cutting structure 620 at the distal end 622. The flanged base 624 extends outward from the intermediate section 628 so as to prevent the box osteotome 618 from extending beyond a certain position when inserted into the standoff 578 and working cannula 506.

The tubular cutting structure 620 may include a rectangular cross-section transverse to a length, and may include pair of wide surfaces 630 having transverse openings 632 therein, and a pair of narrow surfaces 634 extending between the wide surfaces 630. A distal tip 636 of the tubular cutting structure 620 may include rounded cutting surfaces defined on the wide surfaces 630 and linear cutting surfaces on the narrow surfaces 634.

The box osteotome 618 may be oriented in the working cannula 506 such that the wide surfaces 630 of the tubular cutting structure 620 are vertically aligned. In this way, the wide surfaces 630 are generally parallel with the joint plane of the sacroiliac joint, and the narrow surfaces 634 extend across the sacroiliac joint. The tubular cutting structure 620 may be hollow such that bone material may extend into an inner cavity of the cutting structure 620 as the box osteotome 618 is distally advanced within the joint. The distal advancement may cut the surfaces of the sacrum and ilium and cause a portion of the surfaces to extend into the box osteotome 618.

FIGS. 34A-34D are respectively isometric, top, back, and side views of a dual saw blade broach 638. As seen in the figures, the dual saw blade broach 638 may include, at a distal end 644 thereof, a pair of saw blades 640 opposite each other and coupled together via an intra-articular member 642. The saw blades 640 may be serrated along the long edges 646, and each saw blade 640 may include a pair of distal tips 648 opposite each other. Opposite the saw blades 640, the dual saw blade broach 638 may include a flanged base 650 at a proximal end 652 thereof. A button knob 654 may be coupled to the flanged base 650. An intermediate section 656 including a rectangular member may interconnect the flanged base 650 and the saw blades 640 and intra-articular member 642.

The flanged base 650 is sized and shaped to be prevented from extending beyond the standoff 578 when distally advanced relative to the standoff 578 and working cannula 506. The pair of saw blades 640 are oriented, sized and shaped to fit within the passage defined by the keyed inner surfaces 590, 558 of the standoff 578 and working cannula 506 when the saw blades 640 are oriented horizontally. That is, the intra-articular member 642 may extend vertically between the inner protrusions of the inner surfaces 590, 558 of the standoff 578 and working cannula 506.

The saw blades 640 may match a size and shape of features of a joint implant to be subsequently implanted into the joint. For example, a distance between the pair of saw blades 640 may be the same as a distance between the keels of a joint implant, such as the joint implant shown in FIGS. 23-26. The saw blades 640 may cut a pair of channels into the bones of the sacrum and ilium so as to provide an entry path into the joint for the subsequent delivery of the joint

implant. While the dual saw blade broach 638 includes a pair of saw blades 640, the saw blade broach 638 may include a different number and configuration of saw blades 640 to match a particular joint implant.

According to particular embodiments, a final broach may be employed similar in configuration and construction as shown in FIG. 34 yet having saw blades 640 which are thicker and more closely match the thickness of the proximal most portion of the implant keels, which are thicker than the rest of the keels extending the length of the joint implant. The final broach may provide a passageway through the bones defining the sacroiliac joint up to the implant receiving space, the passageway having a set of keel tracks which allow the tapered thicker parts of the keels to pass relatively freely up until or near the proximal end of the implant receiving space. The distance between the distal tips 648 and the flanged base 650 of the final broach is less than the distance between the distal tips 648 and the flanged base 650 of any preceding broach, the distance difference being approximately the length of the implant.

As previously described, the broach 638 may be modified based on the shape of a joint implant 502 to be implanted. For instance, a broach 638 having an X-shaped blade arrangement 640 may be employed to prepare a joint space for the implantation of a joint implant 502 having an X-shaped cross-section. Other cross-sectional shapes of the broach 638 (among other tools) are contemplated herein to match the cross-sectional shape of joint implants 502 to be implanted without limitation.

FIGS. 35A-35D are respectively isometric, top, back, and side views of an anchor arm 508. As seen in the figures, the anchor arm 508 may include a curvate member 658 extending between an anchor block engagement structure 660, and a cannula engagement structure 662. The curvate member 658 may include a proximal section 664 and a distal section 666 that are oriented generally perpendicular to each other. The cannula engagement structure 662 may couple to the anchor arm engagement structure 554 of the working cannula 506, and the anchor block engagement structure 660 may couple to a corresponding structure of the anchor block 510.

The cannula engagement structure 662 of the anchor arm 508 may include a T-shaped end structure 668 extending generally perpendicular to the curvate member 658. The T-shaped end structure 668 may include slots 670 on the top and bottom surfaces thereof that are configured to receive the pair of longitudinally extending tabs 598 of the T-slot 596 of the anchor arm engagement structure 554 of the working cannula 506 so as to couple the anchor arm 508 and the working cannula 506 together.

Opposite the cannula engagement structure 662 is the anchor block engagement structure 660, which may include a T-slot 672 formed by a pair of longitudinally extending tabs 674.

FIGS. 36A-36D are respectively isometric, top, side, and front views of an anchor block 510. The anchor block 510 may be removably coupled to the anchor block engagement structure 660 of the anchor arm 508, and may include superior guide holes 522, inferior guide holes 524, and superior-inferior slots 526 extending through the anchor block 510. The superior guide holes 522 may guide a pin 512 in a predefined trajectory relative to the joint implant 502 that is superior to the joint implant 502. The inferior guide holes 524 may guide a pin 512 in a predefined trajectory relative to the joint implant 502 that is inferior to the joint implant 502.

The anchor block **510** may also include an anchor arm engagement structure **676** including a T-shaped end structure **678** having slots **680** on tops and bottoms thereof for receiving the longitudinally extending tabs **674** of the T-slot **672** of the anchor block engagement structure **660** of the anchor arm **508**. The anchor arm engagement structure **676** may also include a proximal stop **682** so as to prevent the T-slot **672** from disengaging by moving proximally beyond the proximal stop **682**. While the anchor block **510** depicts a series of four superior guide holes **522**, and a series of four inferior guide holes **524**, the anchor block **510** may include a different number and orientation of guide holes. For instance, there may be guide holes positioned along the superior-inferior direction between the superior and inferior guide holes **522**, **524**. And the guide holes may include various trajectories that orient the K-wire in various trajectories relative to the joint implant.

In certain instances, the superior and inferior guide holes **522**, **524** may be spaced apart from each other a distance of about 34 mm. And the adjacent guide holes of the superior guide holes **522** and the inferior guide holes **524** may be spaced apart from each other about 6.25 mm.

The superior-inferior slots **526** may be used to guide the K-wire or pin in a variety of trajectories in a superior-inferior direction while restricting the K-wire or pin from moving laterally. In this way, a K-wire or pin may be angled superior, inferior, or in-line (within the transverse opening) with a joint implant **502** coupled to the implant arm **504**.

FIGS. **37A-37D** are respectively isometric, top, back, and side views of an implant arm **504**. As seen in the figures, the implant arm **504** may include an implant retainer **684** and an arm member **686**. The implant retainer **684** may include a proximal handle **688**, an elongate cylindrical body **690** extending distally from the proximal handle **688**, and a threaded distal end **670**. The implant retainer **684** may be positioned within and through a cylindrical passageway extending longitudinally through the arm member **686**. The arm member **686** may include a proximal handle **692**, a central body **694**, and a distal body **696**. A pair of protrusions **698** extend distally from a distal face **700** of the distal body **696**, and may fit within corresponding recesses in a proximal face of the joint implant **502** so as to prevent rotation of the joint implant **502** relative to the arm member **686**. The threaded distal end **670** of the implant retainer **684** may extend distally out of the passageway of the arm member **686** and be positioned between the pair of protrusions **698**. In this way, the threaded distal end **670** may threadably engage a threaded proximal opening of the joint implant **502** so as to retain the implant **502** against the arm member **686** during delivery of the joint implant into the joint. Accordingly, the implant retainer **684** may rotate within the passageway of the arm member **686** so as to cause the joint implant **502** and the threaded distal end **670** to converge, which causes the joint implant **502** to tighten against the distal face **700** of the distal body **696**. Opposite rotation of the implant retainer **684** may cause decoupling of the joint implant **502** and the implant retainer **684**.

The implant retainer **684** proximal handle **688** and arm member **686** proximal handle **692** both provide a coupling interface with the slide (or slap) hammer assembly (e.g., see FIG. **74**) in order to allow removing the implant from within the sacroiliac joint while still coupled with the implant retainer via a removing force on the proximal handle **688** or in order to assist in the removal of the arm member **686** if it is seized up within the working cannula after the implant retainer has been decoupled from the implant (which will

remain within the sacroiliac joint) and removed from within the cylindrical passageway extending longitudinally through the arm member **686**.

FIGS. **38A-38D** are respectively isometric, top, back, and side views of a joint implant **502**. As seen in the figures, the joint implant **502** may include a pair of planar keels or members **702** spaced apart from each other and coupled together via a distal member **704** at a distal end **706**, and a proximal member **708** at a proximal end **710**. A transverse opening or passageway **712** is defined between the planar members **702**, and the distal and proximal members **704**, **708**.

The planar members **702** may include ridges **714** along its edges, and openings **715** extending through the faces **716** of the members **702**. Near the proximal end **710**, the planar members may taper inward, and the ridges **714** along the edges may extend onto the inward faces of the planar members **702** at the tapered portion. A proximal face **718** of the joint implant **502** may include a pair of recesses **720** for receiving the protrusions **698** of the arm member **686** of the implant arm **504**. The proximal face **718** may also include a central threaded opening **722** for receiving the threaded distal end **670** of the implant retainer **684** of the implant arm **504**.

As seen in FIG. **38C**, the joint implant **502** defines a generally I-beam or H-beam shape that fits through the keyed inner surfaces **590** of the standoff **578** and the inner surface **558** of the working cannula **506**.

FIGS. **39-46** depict various views of a coupling arrangement between a working cannula **506** and an anchor arm **508**. FIG. **39** is an isometric view of an exemplary working cannula **506** and anchor arm **508** coupled thereto. And FIG. **40** is a close up, rear isometric view of the connection between the working cannula **506** and the anchor arm **508**. The working cannula **506** may include many of the features as previously shown in FIGS. **28A-28D**. As seen in FIGS. **39-41**, among others, the working cannula **506** in this instance includes two pin guides **592** positioned between an anchor arm engagement structures **554** which allow the working cannula to be rotated 180 degrees along its axis to treat a contralateral sacroiliac joint while still allowing a guidance pin to be positioned in a PSIS above the treatment site and for the angled opening **734** to be aligned with the sacrum on each joint.

FIG. **41** is an exploded, rear isometric view of the working cannula **506**, anchor arm **508**, and a standoff **578**. As seen in this figure and in FIG. **40**, the standoff **578** may include a three sided tubular body **580** and a three sided flanged base **584** extending outward from the tubular body **580** at a proximal end **582** of the standoff **578**. The tubular body **580** extends to a distal end **586** of the standoff **578**. An inner surface **590** of the standoff **578** is keyed in the shape of an I-beam or H-beam so as to match the inner surface **558** of the passageway **556** of the working cannula **506** when the standoff **578** is positioned within the proximal end **520** of the passageway **556** of the working cannula **506**. Once positioned in the working cannula **506**, the keyed inner surfaces **590** of the standoff **578** and the inner surface **558** of the working cannula **506** are flush or planar with each other.

As particularly seen in FIG. **40**, the cannula engagement structure **662** of the anchor arm **508** fits within the gap within the three sided standoff **578** when the standoff **578** is positioned within the working cannula **506**. More particularly, the cannula engagement structure **662** of the anchor arm **508** may include a pair of generally parallel extension members **724** spaced apart from each other a distance about equal to a thickness of the wall thickness of the working

cannula **506** at the proximal end **520**. The parallel extension members **724** define a slot **726** there between, and the proximal edge of the working cannula **506** may be fitted within the slot **726**. The working cannula **506** may include an opening **728** extending through a thickness thereof at the proximal end **520**, and the pair of extension members **724** may also include a pair of openings **730** that coaxially align with the opening **728** in the working cannula **506** when the edge of the working cannula **506** extends within the slot **726** of the cannula engagement structure **662**. As seen in FIG. **45**, which is a side cross-sectional view of the working cannula **506** and the anchor arm **508** coupled together, the lower opening **730** in the pair of openings **730** on the pair of extension members **724** may be threaded to receive a screw **732** to secure the working cannula **506** and the anchor arm **508** together. There may be two openings **728**, for example, as shown in FIG. **45** such that the anchor arm may couple to either side of the working cannula.

FIG. **46** is a side cross-sectional view of the distal end of the working cannula **506**. As seen in the figure, the prong **548** of the working cannula **506** is centrally positioned along the passageway. One lateral side includes an angled opening **734** that extends into the passageway.

FIG. **47** is an isometric view of a bone anchor **516**. FIGS. **48A-48B** are respectively top and side views of the bone anchor **516** of FIG. **47**. And FIGS. **49A-49B** are respectively back and front views of the bone anchor of FIG. **47**. The anchor **516** may include a longitudinal lumen **528** extending from a proximal end **736** to a distal end **738**. The lumen **528** may receive the pin or K-wire **512** therein so as to guide the anchor **516** in its delivery to the surgical site. The bone anchor **516** may include a body having a bulbous proximal structure **740** including a tool engaging structure **742** such as a hex-key structure and threaded bore formed therein. Extending distally from the bulbous proximal structure **740** is a thread form (e.g., helical) **744** that extends to the distal end **738**. The body includes two flutes **746** extending through the thread form **744** into the lumen **528**. The flutes **746** extend longitudinally along the body, and spiral around the body as they extend in a distal-proximal direction.

At the distal end **738** of the bone anchor **516** may have a self-tapping, self-drilling tip **748** including partial flutes **750** that define individual screw tips **752**. In this way, as the bone anchor **516** is advanced into bone material, the self-drilling tip **748** forms a bore in the bone and forces bone material into the lumen **528** as the anchor is distally advanced.

FIG. **50** is an isometric view of a bone anchor **516** in another instance. FIGS. **51A-51F** are respectively top, first side, second side, third side, back, and front views of the bone anchor **516** of FIG. **50**. As seen in the figures, the bone anchor **516** may include features from the bone anchor **516** in FIGS. **47-49**. The bone anchor **516** of FIGS. **50-51C** includes a longer body (and thread form **744**), a distal slot shaped opening in line with and following the twist of the flutes, a proximal slot shaped opening in line with and following the twist of the flutes, flutes **746** positioned between the distal and proximal slot shaped openings and a flute portion defining a channel (e.g., having a half circle cross section) extending between both the distal slot shaped opening and flute **746** and the flute and the proximal slot shaped opening which cuts into the screw body through the threads but does not extend into the lumen **528**.

FIGS. **52-56** are respectively front isometric, rear isometric, front, side and top views of a flanged implant **502**. As seen in the figures, the flanged implant **502** may include a flange **754** at a proximal end **756**, and an implant body **758** extending generally perpendicular relative to the flange **754**.

The implant body **758** may include a pair of members **760** extending generally perpendicular to the flange **754**, and a distal member **762** coupling the pair of members **760** at a distal end **764** thereof. The distal member **762** may include a rounded distal edge **766**, as seen in FIG. **56**, and a pair of non-parallel or angled surfaces **768**, as seen in FIGS. **54-55**, that extend distally from the pair of members **760** to the distal edge **766**.

The pair of members **760**, the distal member **762** and the flange **754** define a superior-inferior opening **768** extending through the implant body **758**. As seen in FIG. **56**, the superior-inferior opening **768** is rectangular in shape with a rounded distal portion.

The implant body **758** may include ridges **770** extending across the body **758** and in particular across the pair of members **760**. The ridges **770** may act as anti-migration elements that prevent the implant body **758** from proximally displacing from its implanted position in the sacroiliac joint. While the figures depict ridges **770** as the anti-migration elements, other surface features may be included on the implant body **758** without departing from the scope of the present disclosure. For example, indentations, serrations, protrusions, surface irregularities, chevron patterns, and openings, among others, may be included on the implant body **758** additionally or alternatively to the ridges **770**.

As seen in FIGS. **52-55**, the pair of members **760** extending between the flange **754** and the distal member **762** includes transverse openings **772** extending there through. In certain instances, there may be three transverse openings **772** spaced apart from each other and extending from an outer surface of the members **760** to an inner surface.

The flange **754** at a proximal end **756** may include a pair of anchor holes **774** extending there through. The anchor holes **774** may be spaced apart from each other, and may be generally positioned superior to the pair of members **760**. The anchor holes **774** may include a distal opening that is smaller in diameter to a proximal opening so as to prevent the bulbous proximal end of the anchor **516** from extending through the flange **754**. As best seen in FIGS. **52** and **54-56** the anchors **516** may be positioned in a variety of trajectories relative to each other.

FIGS. **57** and **58** depict the implant **502** of FIGS. **52-56** implanted in a sacroiliac joint **1000** defined between a sacrum **1004** and an ilium **1005**. FIG. **57** is a posterior view of the flanged implant **502** bridging across the sacroiliac joint **1000**. FIG. **58** is a posterior-lateral view of the flanged implant **502** bridging across the sacroiliac joint **1000**. As seen in the figures, the flanged implant **502** is implanted into the sacroiliac joint **1000** via posterior delivery such that a plane defining the implant body **758** is transverse to a joint plane defined by the sacroiliac joint **1000**. That is, generally, one of the pair of members **760** is positioned in the ilium **1005** and the other of the pair of members **760** is positioned in the sacrum **1004**, whereas the distal member **762** extends across the sacroiliac joint **1000** and into each of the sacrum **1004** and the ilium **1005**. And, when the implant body **758** is implanted such that the implant bridges across the joint **1000**, one of the anchor holes is positioned over the sacrum **1004**, and the other one of the anchor holes is positioned over the ilium **1005**. Thus, anchors **516** may be delivered into the sacrum **1004** and the ilium **1005** after the implant is delivered into the joint **1000** to secure the implant **502** in position relative to the bones of the joint **1000**.

As seen in FIGS. **57-58**, an angled portion **776** of the sacrum **1004** may be removed to make way for the delivery of the implant **502**. And as seen in the figures, the implant **502** is generally positioned in between the posterior superior



iliac spine **2004** and the posterior inferior iliac spine **778**. That is, the implant body **758** may bridge across the articular region **1044** (not shown in FIGS. **57-58**) of the joint **1000**. And while FIGS. **57-58** depict the implant body **758** positioned in the articular region of the joint, the implant body **758** may alternatively be positioned in the extra-articular region **3007**, among other areas of the joint **1000** for implantation.

The joint implant **502** as seen in FIGS. **52-58** may be used with the working cannula **506** and standoff **578** (among other tools such as the anchor arm **508** and implant arm **504**, as well as others) as previously described. In such an instance, the inner surface **590** of the standoff **578** and the inner surface **558** of the passageway **556** of the working cannula **506** may be keyed in a corresponding shape of the joint implant **502** in FIGS. **52-58**. For example, the inner surfaces **590**, **558** of the standoff **578** and working cannula **506** may be keyed to a flanged implant shape to permit the joint implant **502** and associated tooling to extend there through. Additionally, other tools described herein may similarly be modified to permit passage through inner surfaces that are keyed to the flanged implant shaped cross-section.

FIGS. **59-61** depict various views of an X-shaped implant **502**. In particular, FIGS. **59A-59B** are respectively rear isometric, and side isometric views of a joint implant **502**. FIGS. **60A-60D** are respectively first side, second side, back, and front views of the joint implant **502** of FIGS. **59A-59B**. And FIGS. **61A-61B** are respectively top and bottom views of the joint implant of FIGS. **59A-59B**. As seen in the figures, the X-shaped implant **502** generally includes a proximal end **780**, a distal end **782** and an implant body **784** extending between the proximal and distal ends **780**, **782**. The implant body **784** may include a flattened X-shaped cross section transverse to a length of the implant body **784**. That is, the implant body **784** may include a pair of planar members **786** that are coupled to each other at about a midpoint thereof. The pair of planar members **786** are not perpendicular to each other. Instead, the pair of planar members **786** define a pair of acute angles AA and a pair of obtuse angles OA.

The implant body **784** may include openings extending there through. For instance, the implant body **784** may include a first pair of openings **788** and a second pair of openings **790**, where the first pair of openings **788** are larger and defined on the pair of planar members **786** that define the obtuse angles OA. The second pair of openings **790** may be smaller than the first pair of openings **788** and defined on the pair of planar members **786** that define the acute angles AA. The first pair of openings **788** can be seen in FIGS. **61A** and **61B**, and the second pair of openings **790** can be seen in FIGS. **60A** and **60B**.

The outer edges **792** of the planar members **786** may include ridges, serrations, or other anti-migration elements so as to inhibit migration of the implant **502** after implantation. A proximal face **794** of the implant body **784**, at the proximal end **780**, may be planar. At an opposite end, a distal edge **785** of the implant body **784**, at the distal end **782**, may be rounded. That is, a distal edge **785** of the pair of planar members **786** may be rounded. The proximal face **794** of the implant body **784** may include a threaded proximal bore, or other type of retention feature designed to facilitate couple of the implant **502** to an implant arm **504** of a delivery tool. Alternatively, the implant arm **504** may couple to the planar proximal face **794**.

FIGS. **62-63** depict the joint implant **502** implanted in the sacroiliac joint **1000**. In particular, FIG. **62** is a posterior view of the joint implant **502** bridging across the sacroiliac

joint **1000**. And FIG. **63** is a superior view of the joint implant **502** bridging across the sacroiliac joint **1000**, where the ilium **1005** forming a portion of the sacroiliac joint **1000** is removed to show the position of the joint implant **502**. As seen in FIG. **62**, the joint implant **502** is implanted into the sacroiliac joint **1000** via a posterior access, where the planar members **786** extend or bridge across the joint **1000** and into the sacrum **1004** and the ilium **1005**. That is, each of the pair of members **786** extends across the joint **1000** where one end is positioned in the sacrum **1004** and an opposite end **1005** is positioned in the ilium, with no member lying parallel to a joint plane of the joint **1000**.

Thus, as seen in FIG. **63**, the first pair of openings **788** is oriented vertically or superior-inferior, while the second pair of openings **790** are oriented horizontally or medial-lateral. And as seen in FIG. **62**, the joint implant **502** is positioned between the posterior superior iliac spine **2004** and the posterior inferior iliac spine **778** so as to be positioned within the articular region **1044** of the joint **1000**. And while FIGS. **62-63** depict the implant **502** positioned in the articular region **1044** of the joint **1000**, the implant **502** may alternatively be positioned in the extra-articular region **3007**, among other areas of the joint **1000** for implantation.

The joint implant **502** as seen in FIGS. **59-63** may be used with the working cannula **506** and standoff **578** (among other tools such as the anchor arm **508** and implant arm **504**, as well as others) as previously described. In such an instance, the inner surface **590** of the standoff **578** and the inner surface **558** of the passageway **556** of the working cannula **506** may be keyed in a corresponding shape of the joint implant **502** in FIGS. **59-63**. For example, the inner surfaces **590**, **558** of the standoff **578** and working cannula **506** may be keyed to an X-shaped cross-section to permit the joint implant **502** and associated tooling to extend there through. Additionally, other tools described herein may similarly be modified to permit passage through inner surfaces that are keyed to an X-shaped cross-section.

V. Methods of Preparing and Fusing the Sacroiliac Joint  
The following section describes methods for preparing and fusing the sacroiliac joint **1000**, with reference to FIGS. **64-114**, utilizing systems and tools described in previous sections of this application.

To begin, reference is made to FIG. **64**, which is a side view of a pelvis **1002** with a joint finder **532** positioned proximally thereof. After a patient is anesthetized, and the surgical site is cleaned, a surgeon must locate the joint **1000** in order to prepare the site for a fusion procedure. FIG. **64** as well as many of the other figures in this section show the relevant tools and bones associated with the procedure for clarity. That is, certain steps of the surgical procedure may be omitted herein, but it is understood that other steps may be performed without departing from the scope of the present disclosure.

Accordingly, in FIG. **64**, the patient's tissue adjacent the joint **1000** has been opened (via an incision), and the surgeon may use the joint finder **532** to locate the sacroiliac joint **1000** via a posterior access. As seen in FIG. **65**, which is a side view of the pelvis **1002**, the joint finder **532** may be distally advanced relative to the joint **1000** from the posterior access until the spatulate tip **536** extends into the gap (joint **1000**) between the sacrum **1004** and the ilium **1005**. This provides the surgeon with the location of the sacroiliac joint **1000** and general angular orientation of it. The joint finder **532** may extend into the articular region **1044** of the joint **1044**, which is generally between the posterior superior iliac spine **2004** and the posterior inferior iliac spine **778**.

Alternatively, the procedure may begin with a pin and followed by a cannulated joint finder. Upon identification of the location of the joint **1000**, and as seen in FIG. **66**, the surgeon may advance a pin **796** into the joint **1000** via the posterior access.

FIG. **67** is a side view of a pelvis with the nearest ilium **1005** removed to show the pin **796** in the sacroiliac joint **1000**. The articular region **1044** is highlighted in this view to show the position of the pin **796** in the joint **1000**. As seen in the figure, the pin **796** is generally positioned in a mid-portion of the joint in a superior-inferior direction, and is generally positioned with the distal tip **798** of the pin **796** posterior to an anterior border segment **3004** of the joint.

FIG. **68** is a side view of the pelvis **1002** with the nearest ilium **1005** removed, and a cannulated joint finder **800** positioned over the pin **796** and in the sacroiliac joint **1000**. The cannulated joint finder **800** may include an elongate body **802** with dual spatulate tips **804** at a distal end **806** thereof. A rectangular, block-like handle **808** at a proximal end **810** is coupled to a recessed gripping portion **812** that further couples to the dual spatulate tips **804** that extend to the distal end **806**. The handle **808** and the recessed gripping portion **812** may include a longitudinal bore **814** extending there through that opens into a space between the dual spatulate tips **804**. The longitudinal bore **814** may receive the pin **796**, as seen in FIG. **68**, and guide the cannulated joint finder **800** into the articular region **1044** of the joint **1000**. The cannulated joint finder **800** may exert a pressure against the joint surfaces of the sacrum **1004** and ilium **1005** with sufficient force to hold the joint distractor in position in the joint **1000**.

As seen in FIG. **69**, which is a side view of the pelvis **1002** with the nearest ilium **1005** removed, the working cannula **506** may be positioned over the cannulated joint finder **800** and the pin **796** and in the sacroiliac joint **1000**. In this position, the pair of prongs **548** extends into the articular region **1044** of the joint **1000**, and are positioned superior and inferior to the dual spatulate tips **804** of the joint distractor **800**. Alternatively, if not using the pin and cannulated joint finder but using the joint finder as shown in FIGS. **64-65** the working cannula may be positioned over the joint finder similar to the step shown in FIG. **69**.

FIG. **70** is a posterior view of the pelvis **1002** with the working cannula **506**, cannulated joint finder **800**, and pin **796** positioned in the sacroiliac joint **1000**. It can be seen in this view that pin guide **592** is aligned with the ilium **1005**, and in particular the overhang of the posterior superior iliac spine **2004**.

FIGS. **71-72** depict the next step in the procedure, where FIG. **71** is a superior view of the pelvis **1002** with the working cannula **506**, cannulated joint finder **800**, and a guidance pin **816** positioned in the sacroiliac joint **1000**, and where FIG. **72** is a side view of a pelvis **1002** with the guidance pin **816** secured to the overhang of the posterior superior iliac spine **2004** of the ilium **1005**.

As seen in FIG. **73**, which is a side view of the pelvis **1002**, the pin **796** positioned within the articular region **1044** of the joint **1000** may be removed, and a button knob **818** may be coupled to the proximal end **810** of the cannulated joint finder **800**. The button knob **818** may include a threaded distal end that is threadably engaged with a corresponding threaded portion of the longitudinal bore **814** of the joint distractor **800**. A slide (slap) hammer **820** may be coupled with the button knob **818**, as seen in FIG. **74**. The slide hammer **820** may include an elongate grip **822**, a shaft

**824** extending distally from the elongate grip **822**, and a cylindrical slot **826** for receiving the button knob **818** therein.

Upon coupling the slide hammer **820** to the button knob **818**, the elongate grip **822** may be proximally and if required repeatedly retracted so as to remove the cannulated joint finder **800** from the joint **1000**, as seen in FIG. **75**, which depicts a side view of the pelvis **1002** with the cannulated joint finder **800** removed from within the working cannula **506**, which is still in the joint **1000**. At this stage of the procedure, the working cannula **506** is held in the joint via the guidance pin **816**, which is anchored to the overhang of the posterior superior iliac spine **2004**. And the guidance pin **816** may be secured in position relative to the working cannula **506** via a screw lock **530**.

Next, as seen in FIG. **76**, a depth gauge **560** may be used to determine a suitable depth for preparing the surfaces of the sacrum **1004** and ilium **1005** and for delivering the joint implant **502**. FIG. **77** shows a side view of the pelvis **1002** with the nearest ilium **1005** removed, and the depth gauge **560** positioned through the working cannula **506** and in the joint **1000**. As seen in the figure, a proximal edge **828** of the working cannula **506** aligns with one of the markers **568** indicating a depth of the elongate tongue **562** within the joint **1000**. The surgeon may make note of the depth so that the surfaces of the joint **1000** may be prepared to that depth and so that a correspondingly sized standoff may be selected to limit various further tools to a precise predetermined depth.

Following the depth measurement, the depth gauge **560** may be removed from the working cannula **506**, and a standoff **578** may be positioned within the proximal portion of the passageway **556**. FIG. **78** is a side view of the pelvis **1002** with the standoff **578** positioned proximate the working cannula **506**, and FIG. **79** is a side view of the pelvis **1002** with the standoff **578** positioned within the working cannula **506**. As seen in the figures, the standoff **578** includes a three sided tubular body **580** and a three sided flanged base **584** extending outward from the tubular body **580** at a proximal end **582** of the standoff **578**. The tubular body **580** extends to a distal end **586** of the standoff **578**. An inner surface **590** of the standoff **578** is keyed in the shape of an I-beam or H-beam so as to match the inner surface **558** of the passageway **556** of the working cannula **506** when the standoff **578** is positioned within the proximal end **520** of the passageway **556** of the working cannula **506**.

FIG. **80** is a posterior view of the pelvis once the standoff **578** is positioned within the working cannula **506**. As seen in the figure, a portion of the sacrum **1004** may be removed to make way for an implant **502** as a portion of the sacrum **1004** is visible through the passageway **556** of the working cannula **506**.

Once the standoff **578** is in position within the working cannula **506**, a drill guide insert or drill guide **600** may be inserted into the working cannula **506**, and a drill bit **612** may be used to remove portions of the cartilage and bone from the joint **1000**, sacrum **1004**, and ilium **1005**. To that end, FIG. **81** is a side view of the pelvis **1002** with the nearest ilium **1005** removed, and a drill guide **600** positioned proximate the working cannula **506**. FIG. **82** is a side view of the pelvis **1002** with the nearest ilium **1005** removed, and a drill bit **612** positioned proximate the working cannula **506** and drill guide **600** positioned therein. As seen in FIG. **83**, the drill bit **612** may be guided through a central guide of the drill guide **600**, and into the joint **1000** so as to form a central bore. And, as seen in FIG. **84**, the drill bit **612** may also be guided through a superior guide of the drill guide **600**, and into the joint **1000** so as to form a superior bore in a position

superior to the central bore. In certain instances, the central guide and the superior guide may overlap a portion with each other. In certain instances, the central guide and superior guide may not overlap with each other.

FIG. 85 is a posterior view of the pelvis 1002 with the drill bit 612 positioned in the superior guide of the drill guide 600. In this instance, the drill guide 600 includes three drill guide holes: a superior guide hole 830; a central guide hole 832; and an inferior guide hole 834. As seen in the figure, a portion of the guide holes 830, 832, 834 overlap (i.e., a portion are coextensive). FIG. 86 shows the drill bit 612 extending through the inferior guide hole 834 of the drill guide 600 so as to remove a portion of the bone and/or cartilage of the joint 1000, sacrum 1004, and ilium 1005.

After utilizing the drill guide 600, a box osteotome 618 (or series of smaller to larger box osteotomes) may be utilized to further prepare the joint surfaces of the sacrum 1004 and ilium 1005, as seen in FIGS. 87-88. FIG. 87 depicts the box osteotome 618 proximate the working cannula 506 and FIG. 88 depicts the box osteotome 618 positioned through the working cannula 506 such that the cutting structure 620 extends into the articular region 1044 of the joint so as to remove a rectangular portion of the joint space formed by the sacrum 1004 and ilium 1005.

Now that a central portion or plane of the joint 1000 has been prepared, portions of the sacrum and ilium 1004, 1005 may be prepared to receive certain features of the joint implant 502. For instance, FIGS. 89-91 illustrate a dual saw blade broach 638 for use in forming keel-cuts or transverse cuts into the sacrum 1004 and ilium 1005 to receive keels or planar members of a joint implant 502. FIG. 89 depicts the dual saw blade broach 638 positioned proximate the working cannula 506. FIG. 90 is a superior view of the dual saw blade broach 638 showing the serrations along the long edges 646 thereof. And FIG. 91 is a side view of the pelvis 1002 with the nearest ilium removed 1005, with the dual saw blade broach 638 positioned through the working cannula 506 and into the joint 1000 so as to form transverse cuts or channels in the sacrum 1004 and ilium 1004 corresponding to the size and shape of the implant 502 to be implanted subsequently. A series of smaller to larger broaches or chisels may be used.

FIGS. 92-95 depict the implantation of the joint implant 502 in the joint 1000, and, in particular, in the implant receiving space as prepared by the various tools and methods previously described. FIG. 92 is a side view of the pelvis 1002 with the nearest ilium 1005 removed, and a joint implant 502 coupled with an implant arm 504 that is positioned proximate the working cannula. As seen in the figure, the joint implant 502 is oriented with the pair of planar members 702 oriented perpendicular to a plane of the joint 1000, and with the transverse opening 712 extending across the joint 1000 (i.e., perpendicular to a plane of the joint). FIG. 93 is a superior view of the joint implant 502 coupled with the implant arm 504 positioned proximate of the working cannula 506. It can be seen that the trajectory of the implant arm 504 and implant 502 are aligned with a trajectory of the working cannula 506 so the joint implant 502 can pass through the keyed passageway 556 of the working cannula 506.

FIG. 94 is a side view of the pelvis 1002 with the nearest ilium 1005 removed, and with the joint implant 502 positioned in the joint 1000. And FIG. 95 is a superior view of the joint implant 502 positioned in the joint 1000. The joint implant 502 is coupled to the implant arm 504, which extends through the working cannula 506. The planar members 702 of the implant 502 are now positioned within the

channels formed by the dual saw blade broach 638, and the distal and proximal members 704, 708 are positioned within the plane of the joint 1000 which was prepared and widened by the drill bit 612 and box osteotome 618.

Upon the joint implant 502 being implanted into the joint 1000, the anchor arm 508 may be coupled to the working cannula, as seen in FIG. 96-100. FIGS. 96-97 show the anchor arm 508 positioned proximate the working cannula 506. And FIGS. 98-100 show the anchor arm 508 coupled with the working cannula 506. In particular, FIGS. 98-100 depict respectively a superior view, posterior view, and a side view of the cannula engagement structure 662 of the anchor arm 508 engaged with the anchor arm engagement structure 554 of the working cannula 506.

In certain aspects, the anchor arm 508 may be locked or otherwise retained to the working cannula 506 via a detent (e.g., ball detent), clamp, peg, screw, switch, latch, cam lock, spring latch, pawl, other fasteners, locking mechanisms or retaining mechanisms.

A benefit of particular configurations of the anchor arm-working arm coupling arrangement is that the joint implant 502 may be positioned in the joint 1000 and with the joint implant still coupled to the implant arm and extending through the working cannula, the anchor arm may be joined therewith unobstructed and due to the rigid connection between the implant receiving space, the implant, the implant arm and the working cannula the alignment and orientation of the working cannula and thereby anchor arm may be maintained throughout the deployment and use of the anchor arm, anchor block, pin etc.

Once the anchor arm 508 is coupled to the working cannula 506, the anchor block 510 may be coupled to the anchor arm 508, as seen in FIGS. 101-103, which depict respectively a side view, a posterior view, and a superior view of the anchor block 510 coupled to the anchor arm 508. The anchor block 510 may include superior guide holes 522, inferior guide holes 524, and superior-inferior slots 526 extending through the anchor block 510. The superior guide holes 522 may guide a pin 512 in a predefined trajectory relative to the joint implant 502 that is superior to the joint implant 502. The inferior guide holes 524 may guide a pin 512 in a predefined trajectory relative to the joint implant 502 that is inferior to the joint implant 502. The anchor block 510 may also include the anchor arm engagement structure 676 that couples to the anchor block engagement structure 660 of the anchor arm 508.

In certain aspects, the anchor block 510 may be locked or otherwise retained to the anchor arm 508 via a detent (e.g., ball detent), clamp, peg, screw, switch, latch, cam lock, spring latch, pawl, other fasteners, locking mechanisms or retaining mechanisms.

FIGS. 104-106 depict various views of a pin 512 extending through and being guided by one of the superior guide holes 522 of the anchor block 510. More particularly, FIG. 104 is a side view, FIG. 105 is a posterior view, and FIG. 106 is a superior view of the pelvis 1002 with an anchor block 510 coupled to the anchor arm 508, which is coupled to the working cannula 506, and a pin or K-wire 512 guided towards the ilium 1005 via the anchor block 510.

FIG. 107 is a superior view of the pelvis 1002 that depicts the pin 512 extending into the ilium 1005 via guidance by the guide block 510 of the anchor arm 508. Upon the pin 512 extending into the ilium 1005 (or further into the sacroiliac joint, or even further into the sacrum), the guide block 510 may be removed from the anchor arm 508, as seen in FIG. 108. More particularly, the guide block 510 may be disengaged or slid away from the pin 512 and anchor arm 508

along a trajectory that is generally parallel to the pin 512. In this way, disengagement of the guide block 510 from the anchor arm 508 limits or eliminates inadvertent bending or displacement of the pin 512.

Additionally, the implant arm 504 may be decoupled from the implant 502 via disengagement of the implant retainer 684 from the proximal bore of the implant (or other feature of the implant that couples the implant arm 504 and implant 502, respectively), and the implant arm 504 may be removed from within the working cannula 506. And, the working cannula 506 and anchor arm 508 (coupled thereto) may be removed from being coupled to the joint area by loosening the screw lock 530 from engagement with the guidance pin 816 extending through the pin guide 592 of the working cannula 506. Upon loosening the screw lock 530, the working cannula 506 may be slidably removed from engagement with the guidance pin 816, and then the guidance pin 816 may be removed from the overhang of the posterior superior iliac spine 2004. Alternatively, the pin 816 may be removed from the overhang of the posterior superior iliac spine 2004, and from the working cannula 506 prior to the working cannula 506 being removed from the joint 1000.

With the pin or K-wire 512 positioned in the ilium 1005, a bone anchor 516 may be guided into engagement with the ilium 1005, joint 1000, and sacrum 1004 via the pin 512, as seen in FIG. 109, which is a superior view of the pelvis 1002 with the K-wire 512 remaining in the pelvis 1002, but with the rest of the tools removed. The pin 512 is received within the lumen 528 of the bone anchor 516, and the bone anchor 516 is distally advanced into the bones and joint. As described previously, the bone anchor 516 may include a self-tapping, self-drilling tip 748 to aid in the advancement of the anchor 516 into the bone.

FIG. 110 depicts the anchor 516 fully delivered into the ilium 1005, joint 1000, and sacrum 1004 via guidance by the pin 512. FIG. 111 depict a side view of the pelvis 1002 with the bone anchor 516 in position and with the pin 512 removed from the lumen 528 of the pin 512. FIGS. 112 and 113 depict the positions of the joint implant 502 and the anchor 516 relative to each other and relative to the joint 1000 is a side view and a posterior view, respectively, of the pelvis 1002 with the nearest ilium 1005 removed.

And FIG. 114 is an isometric side view of the joint implant 502 and the bone anchor 516 in position adjacent each other in an implanted orientation in the joint (not shown). As seen in FIGS. 112-114, the anchor 516 is positioned superiorly to the joint implant 502, and generally in-line with the distal member 704 at the distal end 706. The implanted orientation of the anchor 516 may be dependent on the particular guide hole 522 of the anchor block 510 that the pin 512 was guided by. In this particular instance, the anchor 512 was guided by a most anteriorly positioned guide hole of the superior guide holes 522 of the guide block 510. The other guide holes of the superior guide holes 522 were posterior, meaning the ultimate position of the anchor 516 would be posteriorly positioned to the anchor placement as shown in FIG. 114.

VI. Additional or Alternative Tools including the Working Cannula, Anchor Arm, Pin Guide, Joint Finder, and Broach

FIGS. 115 and 116 depict, respectively, a distal isometric view of an exemplary working cannula 506, an anchor arm 508, and a pin guide 592 removably coupled together, and a proximal isometric view of the exemplary working cannula 506, the anchor arm 508, and pin guide 592 uncoupled from each other. As seen in the figures, the working cannula 506 may include a pair of prongs, spikes, or projections 548 at a distal end 550 thereof, a tubular body 552 extending

proximally from the pair of prongs 548, and a pair of through holes 900, 902 extending transversely through the tubular body 552. A passageway 556 extends through the working cannula 506 from a proximal end 520 to the distal end 550.

Within the working cannula 506 is a passageway 556 that extends from the proximal to distal ends 520, 550. An inner surface 558 of the working cannula 506 may be keyed in the shape of a corresponding outer surface of an implant arm (not shown). The tubular body 552 may include indentations 904 for gripping, and a flange 914 just proximal of the indentations 904 at the proximal end 520. The working cannula 506 may include features from the working cannula 506 as previously described.

The pin guide 592 may include a pair of cylindrical eyelets or rings 906 that define a passageway for aligning a guide pin 514 along an axis that is in parallel alignment with a longitudinal axis 594 of passageway 556 of the working cannula 506. The guide pin 514 may be secured in position relative to the working cannula 506 by tightening a screw lock 530. As seen in the figures, the pin guide 592 is positioned on a superior side of the working cannula 506 so as to guide a guide pin into a portion of the ilium (e.g., posterior superior iliac spine) while aligning the longitudinal axis 594 of the passageway 556 of the working cannula 506 with the articular region of the sacroiliac joint.

The pin guide 592 may include a partial sleeve 908 including a cylindrical inner surface 910 and screw locks 912 for coupling the pin guide 592 to the working cannula 506. When the inner surface 910 of the pin guide 592 is positioned over the tubular body 552, the screw locks 912 may be engaged with the distal through holes 900 of the tubular body 552 so as to secure the pin guide 592 to the working cannula 506.

The anchor arm 508 may include a partial sleeve 916 including a cylindrical inner surface 918 and screw locks 920 for securing the anchor arm 508 to the working cannula 506. When the inner surface 918 of the partial sleeve 916 of the anchor arm 508 is positioned over the tubular body 552, the screw locks 920 may be engaged with the proximal through hole 902 so as to secure the anchor arm 508 to the working cannula 506. The anchor arm 508 may include features from the anchor arms 508 as previously described. For example, the anchor arm 508 may include an anchor block 510 opposite the partial sleeve 916 (removably coupled or rigidly coupled to the curvate member 658). The anchor block 510 may include one or more guide holes (not shown) for guiding a pin, which may then be used to guide an anchor, as described in previous embodiments.

With the coupling arrangements of the anchor arm 508 to the working cannula 506, and the pin guide 592 to the working cannula 506, the passageway 556 into the working cannula 506 remains open and unobscured for the passage and/or movement of an implant arm (not shown) therein.

FIGS. 117A-117C depict, respectively, a pair of isometric side views, and a back view of a joint finder 532. The joint finder 532 of FIGS. 117A-117C may include similar features to the joint finders 532 as previously described. In the present instance, the joint finder 532 may include an I-beam or H-beam shaped handle 542 that is integral with the body 534 thereof. As with the embodiment in FIGS. 27A-27D, the joint finder 532 was configured to couple to a round knob at the proximal end 544 via a threaded connection. In the present instance, the handle 542 may be integral with the body 534 and also be keyed to the shape of the inner surface of the working cannula 506 (not shown).

As seen in the figures, the joint finder 532 may include the elongate body 534 with a spatulate tip 536 at a distal end 538

thereof, a transverse opening 540 extending between sides of the body 534, the handle 542 at a proximal end 544, and a recessed gripping portion 546 just distal of the handle 542. The spatulate tip 536 may be used to identify the opening or gap between the sacrum and the ilium. Upon identifying the opening or gap between the sacrum and ilium, the spatulate tip 536 may be advanced into the sacroiliac joint.

FIGS. 118A-118B depict, respectively, an isometric side view and an isometric exploded side view of a broach 638. The dual saw blade broach 638 as seen in the figures may include, a distal body 922 at a distal end 644 thereof that may be manufactured separable from and configured to couple to (via welding or otherwise joined to) an intermediate section 656 of the broach 638.

The distal body 922 may include a pair of saw blades 640 opposite each other and coupled together via an intra-articular member 642. The saw blades 640 may be serrated along the long edges 646, and each saw blade 640 may include a pair of distal tips 648 opposite each other. Opposite the saw blades 640, the distal body 922 may include a proximal base 924 configured to fit within a slot 926 formed by a pair of flattened tines 928 at a distal end 930 of the intermediate section 656. The distal body 922 may be constructed as a single unitary piece. And upon forming, the distal body 922 may be welded or otherwise joined to the intermediate section 656.

The intermediate section 656 may include a rectangular member that extends proximally from the flattened tines 928. The rectangular member may interconnect with a flanged base 650 at a proximal end 652 thereof. A button knob 654 may be coupled with the flanged base 650. In certain instances, the button knob 654 may be integral with the flanged base 650.

The flanged base 650 may be sized and shaped to be prevented from extending beyond the standoff 578 when distally advanced relative to the standoff 578 and working cannula 506. The pair of saw blades 640 are oriented, sized and shaped to fit within the passage defined by the keyed inner surfaces 590, 558 of the standoff 578 and working cannula 506 when the saw blades 640 are oriented horizontally. That is, the intra-articular member 642 may extend vertically between the inner protrusions of the inner surfaces 590, 558 of the standoff 578 and working cannula 506.

The saw blades 640 may match a size and shape of features of a joint implant to be subsequently implanted into the joint. For example, a distance between the pair of saw blades 640 may be the same as a distance between the keels of a joint implant, such as the joint implant shown in FIGS. 23-26. The saw blades 640 may cut a pair of channels into the bones of the sacrum and ilium so as to provide an entry path into the joint for the subsequent delivery of the joint implant. While the dual saw blade broach 638 includes a pair of saw blades 640, the saw blade broach 638 may include a different number and configuration of saw blades 640 to match a particular joint implant.

The foregoing merely illustrates the principles of the embodiments described herein. Various modifications and alterations to the described embodiments will be apparent to those skilled in the art in view of the teachings herein. It will thus be appreciated that those skilled in the art will be able to devise numerous systems, arrangements and methods which, although not explicitly shown or described herein, embody the principles of the embodiments described herein and are thus within the spirit and scope of the present disclosure. From the above description and drawings, it will be understood by those of ordinary skill in the art that the particular embodiments shown and described are for pur-

poses of illustrations only and are not intended to limit the scope of the present disclosure. References to details of particular embodiments are not intended to limit the scope of the disclosure.

What is claimed is:

1. A system for performing a fusion procedure on a sacroiliac joint defined between a sacrum and an ilium, the system comprising:

a working cannula comprising a proximal end, a distal end, a tubular body extending between the proximal and distal ends, a cannula passageway defined within the tubular body and having a cannula axis extending there through, a pair of prongs coupled to the tubular body and extending distally there from, an anchor arm engagement structure coupled to the tubular body, and a pin guide coupled to the tubular body and defining a pin passageway having a guidance axis there through that is generally parallel with the cannula axis; and

an anchor arm including a cannula engagement structure configured to couple to the anchor arm engagement structure of the working cannula, the anchor arm further comprising an elongate member coupled to the cannula engagement structure.

2. The system of claim 1, wherein the pair of prongs lie in a plane that intersects the cannula axis.

3. The system of claim 1, wherein the pair of prongs lie in a plane that intersects the guidance axis.

4. The system of claim 1, wherein the pair of prongs lie in a plane that intersects the cannula axis and the guidance axis.

5. The system of claim 1, wherein the tubular body comprises an inner surface that defines the cannula passageway, the inner surface including a pair of protrusions extending inward from opposite sides of the inner surface.

6. The system of claim 1, wherein the anchor arm further comprises an anchor block engagement structure, and wherein the elongate member is coupled to the anchor block engagement structure.

7. The system of claim 6, further comprising an anchor block including an anchor arm engagement structure configured to couple to the anchor block engagement structure of the anchor arm, the anchor block comprising a plurality of guide holes extending through the anchor block and configured to guide a pin along a trajectory.

8. The system of claim 7, wherein the anchor block further comprises at least one guide slot having an elongated opening extending there through, the at least one guide slot configured to guide a tool along a plurality of trajectories that are limited to those generally within a plane defined by the elongated opening.

9. The system of claim 8, wherein the tool comprises a pin.

10. The system of claim 1, further comprising a standoff comprising a tubular body configured to be positioned within the passageway of the working cannula at the proximal end.

11. The system of claim 10, wherein the standoff further comprises an inner surface including a pair of protrusions extending inward from opposite sides of the inner surface, wherein, when the standoff is positioned within the passageway of the working cannula the pair of protrusions of the standoff and working cannula, respectively, are collinear with each other.

12. The system of claim 1, further comprising an implant arm comprising an implant retainer and an arm member, the implant retainer comprising a shaft having a threaded end

51

configured to couple to a joint implant, the arm member comprising a passageway for receiving the shaft of the implant retainer therein.

13. The system of claim 12, further comprising the joint implant.

14. The system of claim 13, wherein the joint implant comprises an implant body including at least one planar member extending a length between a proximal end and a distal end, and an opening extending through the implant body.

15. The system of claim 14, wherein the implant body defines X-shaped cross-section.

16. The system of claim 14, wherein the joint implant further comprises a flange coupled to the implant body, the flange being generally perpendicular to the implant body, the at least one planar member comprising a first planar member, the opening extending through the first member.

17. The system of claim 1, wherein the inner surface of the tubular body of the working cannula is keyed to a cross-sectional shape of a joint implant to permit passage of the joint implant therethrough.

18. The system of claim 17, further comprising the joint implant.

19. The system of claim 1, wherein the tubular body comprises an inner surface that defines the cannula passageway, the inner surface defining a non-circular perimeter.

20. The system of claim 1, further comprising: the anchor arm further comprising an anchor block engagement structure, and wherein the elongate member is coupled to the anchor block engagement structure;

an anchor block including an anchor arm engagement structure configured to couple to the anchor block engagement structure of the anchor arm, the anchor block comprising a plurality of guide holes extending through the anchor block and configured to guide a pin along a trajectory; and

an implant arm comprising an implant retainer and an arm member, the implant retainer comprising a shaft having a threaded end configured to couple to a joint implant, the arm member comprising a passageway for receiving the shaft of the implant retainer therein, wherein, movement of the implant arm and the joint implant is independent of movement of the working cannula, the anchor arm, and the anchor block.

21. A method of performing a fusion procedure on a sacroiliac joint defined between a sacrum and an ilium, the sacroiliac joint comprising an articular region, the ilium comprising a posterior superior iliac spine (PSIS) and a posterior inferior iliac spine (PIIS), the method comprising:

inserting a distal tip of a working cannula between the sacrum and the ilium via a posterior access, the distal tip comprising a pair of prongs separated from each other by a distance, the working cannula comprising a tubular body, a cannula passageway extending through

52

the tubular body, a pin guide coupled to the tubular body and defining a pin passageway having a guidance axis there through that is generally parallel with the cannula axis, and an anchor arm engagement structure; inserting a guide pin into the ilium;

securing the guide pin to the pin guide; inserting a joint implant through the cannula passageway and at least partially into the articular region of the sacroiliac joint;

coupling a cannula engagement structure of an anchor arm to the anchor arm engagement structure of the working cannula;

coupling an anchor block to the anchor arm, the anchor block comprising a plurality of guide holes extending there through;

inserting a pin through one of the plurality of guide holes and into the ilium along a trajectory defined by the one of the plurality of guide holes; and

guiding a bone anchor into the ilium via guidance by the pin.

22. The method of claim 21, further comprising inserting a distal portion of a cutting tool through the cannula passageway and into the sacroiliac joint so as to prepare the sacrum and the ilium for insertion of the joint implant.

23. The method of claim 22, wherein the cutting tool comprises at least one tool from a group comprising a rasp, a drill bit, a saw blade, and a box osteotome.

24. The method of claim 21, wherein securing the guide pin to the pin guide is via a screw lock of the pin guide.

25. The method of claim 21, wherein the tubular body comprises an inner surface that defines the cannula passageway, the inner surface including a pair of protrusions extending inward from opposite sides of the inner surface.

26. The method of claim 21, further comprising decoupling the anchor block from the anchor arm prior to guiding the bone anchor into the ilium by the pin.

27. The method of claim 21, further comprising decoupling the cannula engagement structure of the anchor arm and the anchor arm engagement structure of the working cannula prior to guiding the bone anchor into the ilium by the pin.

28. The method of claim 21, wherein the guide pin is inserted into the PSIS of the ilium.

29. The method of claim 28, further comprising removing bone material from the PSIS in preparation for inserting the guide pin therein.

30. The method of claim 29, further comprising implanting the bone material into at least one or both of the joint implant and the sacroiliac joint.

31. The method of claim 21, wherein the joint implant is inserted at least partially into the articular region of the sacroiliac joint via a posterior access region defined between the PSIS and the PIIS.

\* \* \* \* \*